

GF30.20-P-4011-02C	Pedal value sensor design	Model 203	 GF
--------------------	---------------------------	-----------	--

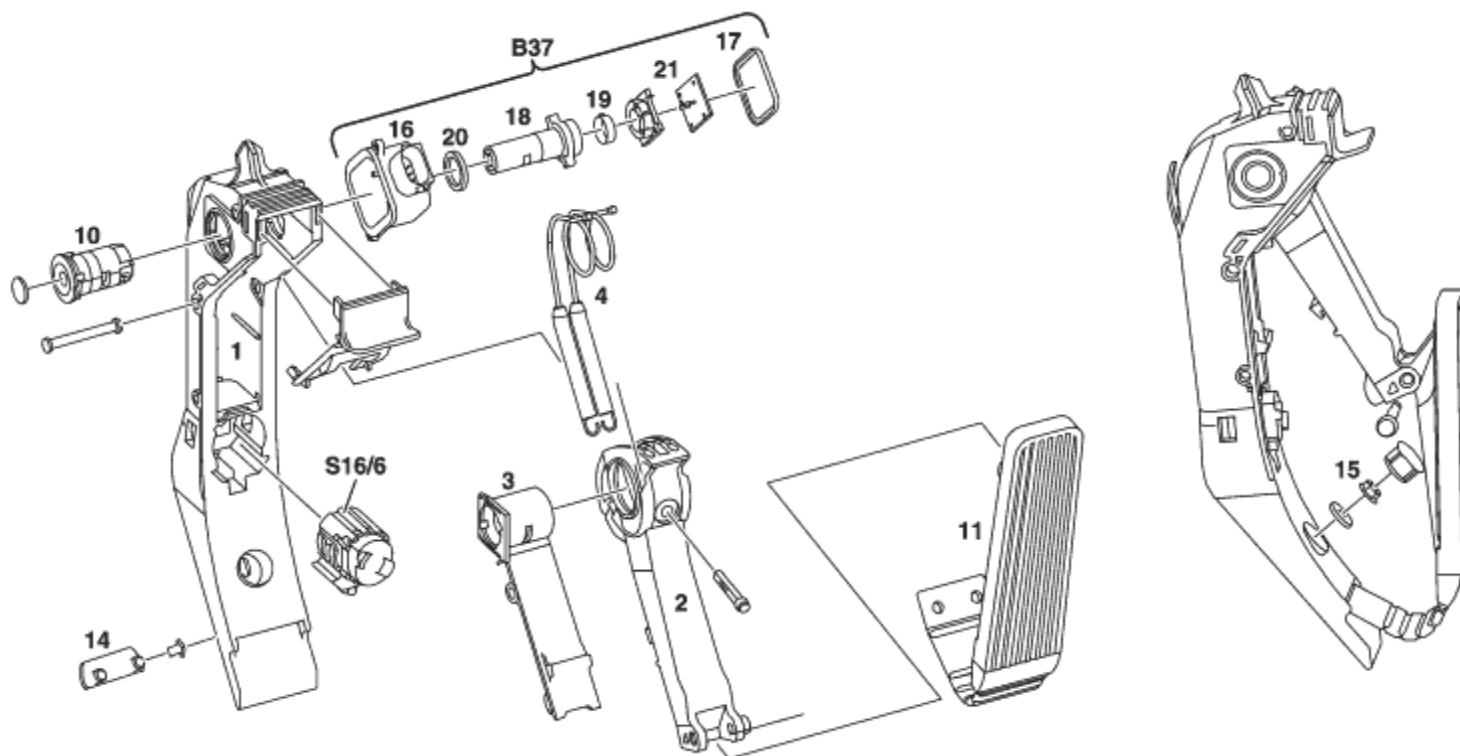

P30.20-2013-09

Illustration shows accelerator pedal module with kickdown switch (S16/6).

Was only installed until about 7/02. One then used the accelerator pedal module with kick-down simulator (a).

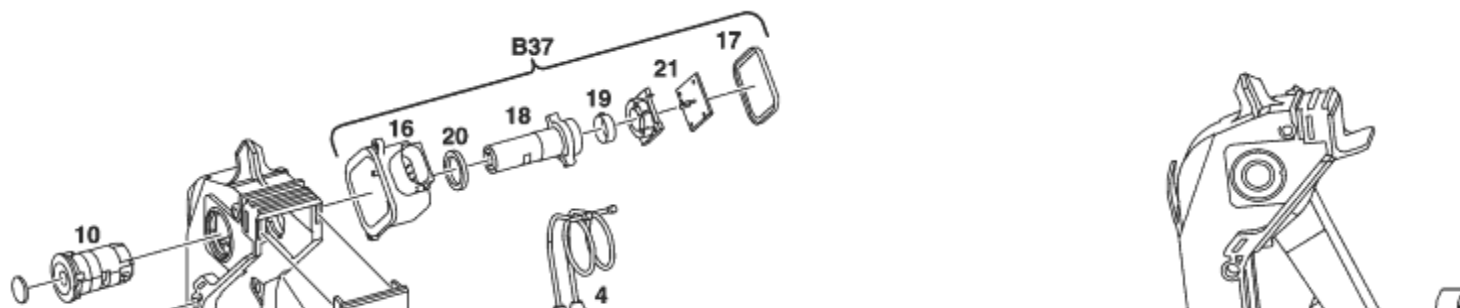

P30.20-2046-09

Illustration shows accelerator pedal module with kickdown simulator (a).

1 Base plate	15 Cap
2 Pedal lever	16 Housing of pedal value sensor
3 Friction ring	17 Cover
4 Friction cables with spring	18 Shaft with magnet mount
10 Spline shaft	19 Ring magnet
11 Accelerator pedal	20 Sealing ring
14 Detent plate for attaching accelerator pedal	21 Printed circuit board with stator and Hall electronics

B37 Accelerator pedal sensor
S16/6 Kickdown switch (up to 7/02)
A Kickdown simulator



Replace accelerator pedal module always complete!

Illustration shows internal circuitry of pedal value sensor B37 (Hall principle)

B Magnetic flux density
X Component standard for Hall element
LL Closed throttle position.
VL Full-load position

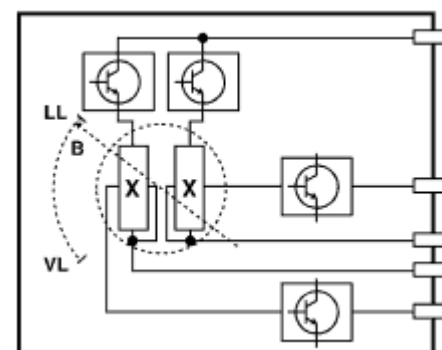

P30.20-0226-01

The sensor on the accelerator pedal which works according to the Hall principle is integrated into the pedal lever axis. It consists of a shaft with ring magnet. This rotates in a printed circuit board with stator in the fixed Hall elements. This produces a change in the voltage.

The accelerator pedal sensor is supplied by the engine control unit with 5 V. The information regarding the accelerator pedal position is passed on to the engine control unit by means of two voltages (pin 4: approx. 0 to 2.25 V and pin 5: approx. 0 to 4.5V).

The kick-down switch (S16/6) was no longer used from 7/02. Full load recognition takes place now over the signal from the accelerator pedal sensor. The pressure point on the accelerator pedal is simulated before achieving the full load position.