

# Intake Functional Diagram

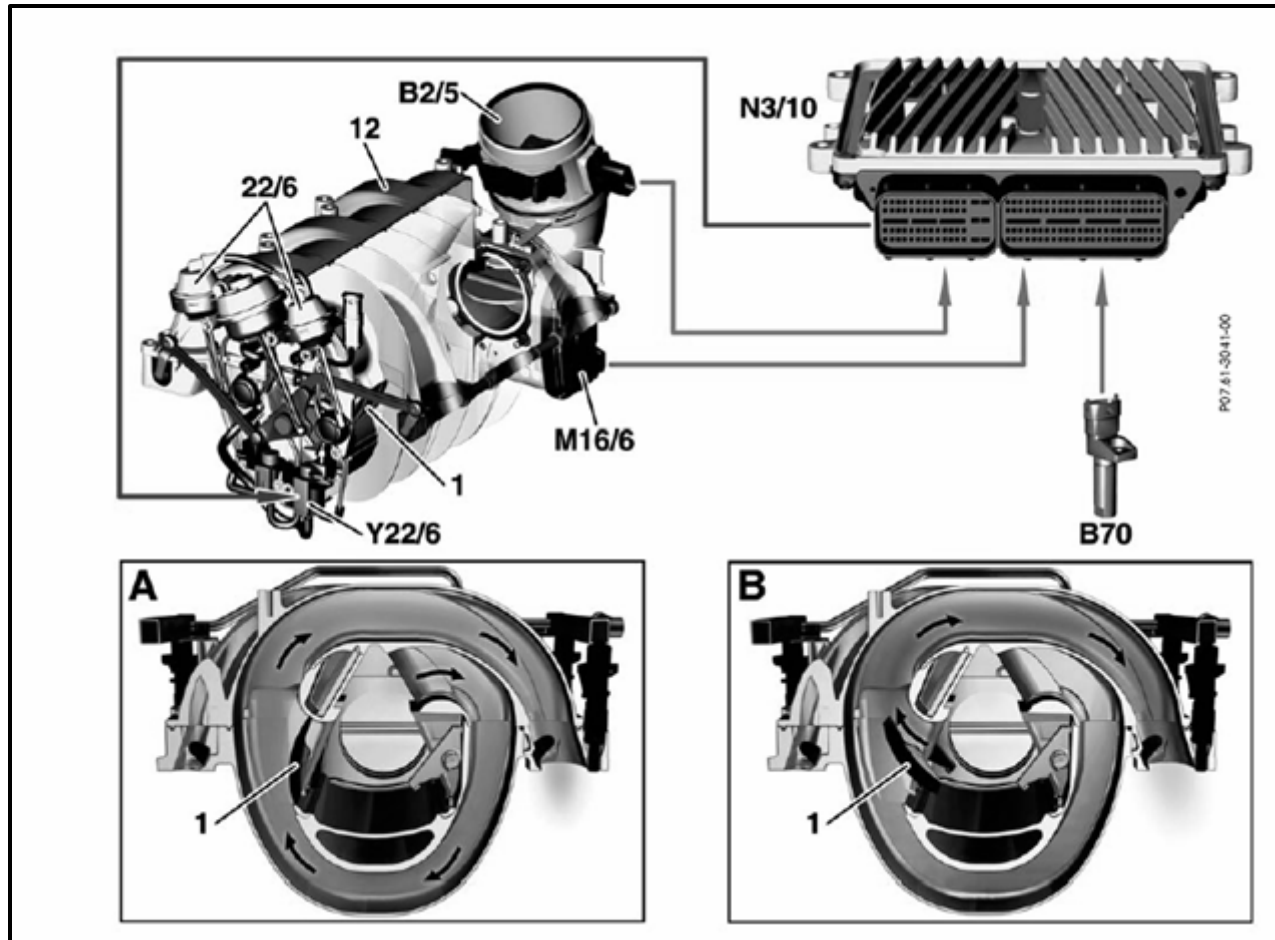

A – Long runner

B – Short runner

1- Switchover flaps

12 – Intake manifold with integral vacuum reservoir

B2/5 – Hot film mass airflow sensor

22/6 – Intake manifold switchover diaphragm

Y22/6 – Variable intake manifold switchover valve

M16/6 – Throttle valve actuator

B70 – Crankshaft hall sensor

N3/10 – ME 9.7