

# Impulse Wheels

- Four impulse wheels used on the M272 mounted on the front of each camshaft timing adjuster
  - Each impulse wheel has a different part number
- The openings of the impulse wheels help ME determine the camshafts exact position
- **Can only be used one time!**
- **If new impulse wheels are not used the pins could shear off causing massive damage to adjusters**

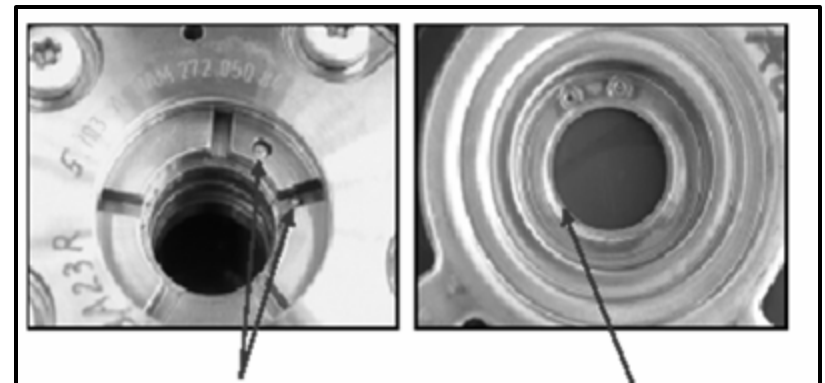
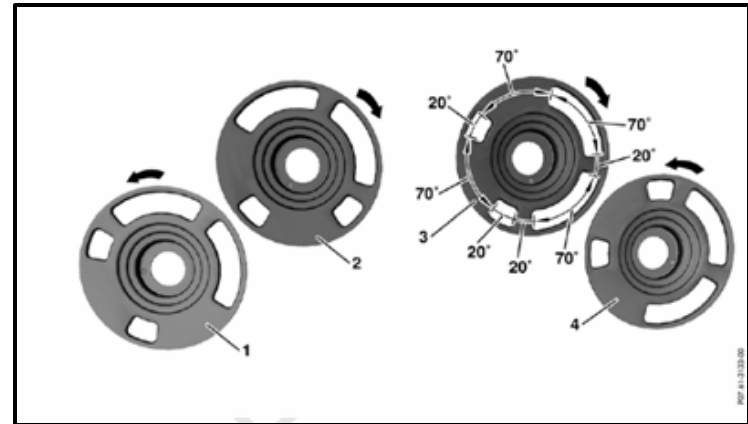

Both locating pins sheared off when reinstalled

Gouging of mounting surface