

**DTB**

Date: August 29, 2008
Order No.: P-B-82.10/376e
Supersedes: P-B-82.10/376d dated May 23, 2008
Group: 82

Revision History

Revision	Date	Purpose
e	8/29/08	1 st Paragraph Updated (Removed Reference to Fault Codes)
d	5/23/08	Damage Type for Step 7 Updated
c	12/12/06	Warranty Information Updated
b	5/30/06	Warranty Information Updated
a	5/8/06	Applicable Models / Technical Content / Parts and Warranty Information Updated
-	3/17/04	Initial issue

SUBJECT: Model 203.040/061/064/065/076/081/084/261/264/281/284/740/747/764

Model 209.365/375/376/465/475/476

Model 230.474/475/476/479

Xenon or Bi-Xenon Headlamps not Functioning

If you receive customer reports in the above model vehicles regarding the Xenon or Bi-Xenon headlamp not functioning, follow the test steps below to resolve. A function description can be found in WIS document GF82.10-P-2001P (203), GF82.10-P-0003Q (209) or GF82.10-P-3002R (230).

A. Fault Code Present

1. Check voltage at headlamps.
 - a. Check plug (1) of low beam (E1e2, E2e2) in lamp units (E1, E2) for voltage.
 - b. If no voltage is present, continue with test step 5.
 - c. If voltage is present, continue with test step 2.
2. Check burners by swapping across (right to left).
 - a. If the fault changes sides with the xenon burner, replace xenon burner. Refer to WIS document AR82.10-P-1201P (203), AR82.10-A-1201QB (209) or AR82.10-P-1201R (230).
 - b. If the fault does not change sides, continue diagnosis with test step 3.
3. Check ignition module.
 - a. Check manufacture date of ignition module found on a printed label (Figure 1, arrow) on the headlamp housing.

This bulletin has been created and maintained in accordance with MBUSA-SLP S423QH001, Document and Data Control, and MBUSA-SLP S424HH001, Control of Quality Records.

Model	Headlamp Vendor	After Manufacture Date
203	Automotive Lighting	22.04.2003
209	Automotive Lighting	22.04.2003
209	Hella	28.04.2003
203.7	Hella	05.05.2003
230	Automotive Lighting	07.07.2003

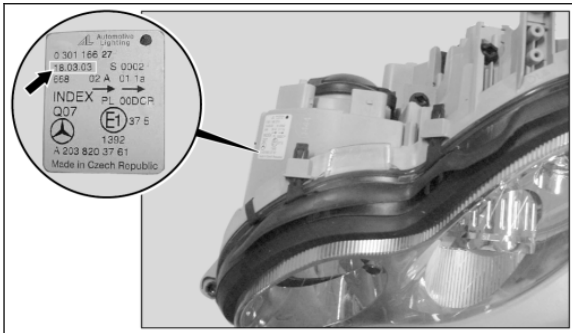

Figure 1 P-B-82.10/376a

- b. If the ignition module is later than the specified manufacture date, continue with test step 4.
 - c. If the ignition module is earlier than the specified manufacture date, continue with test step 6 for the 230, test step 7 for the 203.0 and 203.2 and test step 8 for the 203.7 and 209.

4. Check control unit. Replace the control unit only if a fault is present. If there is no fault, continue with test step 5.

5. Check voltage at front SAM (N10/1), plug 5, pin 4. If there is no voltage, check and correct to repair symptom.

6. For 230 models with this complaint and with headlamps manufactured on or before manufacture dates (Figure 1) in the above table, proceed as follows to resolve.
 - 6.1 Remove affected headlamp(s). Reference WIS document no. AR82.10-P-4730R.
 - 6.2 Unlock and remove housing cover on rear of headlamp unit at the tab.
 - 6.3 Twist headlamp unit's ignition module plug to the left and remove.
 - 6.4 Remove the screws from the ignition module cover.
 - 6.5 Remove old and install new ignition module.
 - 6.6 Reinstall remaining parts in reverse order.
 - 6.7 Test operation of headlamp(s).

7. For 203.0 & 203.2 models with this complaint and with headlamps manufactured on or before manufacture dates (Figure 1) in the above table, proceed as follow to resolve.
 - 7.1 Remove front wheel. Reference WIS document no.AP40.10-P-4050Z.
 - 7.2 Remove front fender liner. Reference WIS document no. AR88.10-P-1300P.
 - 7.3 Disconnect plug from headlamp.
 - 7.4 Unlock and remove housing cover on rear of headlamp unit at the tab.

- 7.5 Twist plug on burner to the left and remove (Figure 2, arrow).
- 7.6 Remove retaining collar (Figure 3, right circle) and scrap retaining collar.
- 7.7 Remove burner.

⚠ Caution! Do not touch the glass portion of the burner with bare hands; otherwise the glass envelope will shatter when energized. Use a non-greasy, soft cloth.

- 7.8 Cut off burner plug as close to the ignition module as possible (Figure 3, left circle) and scrap burner plug.

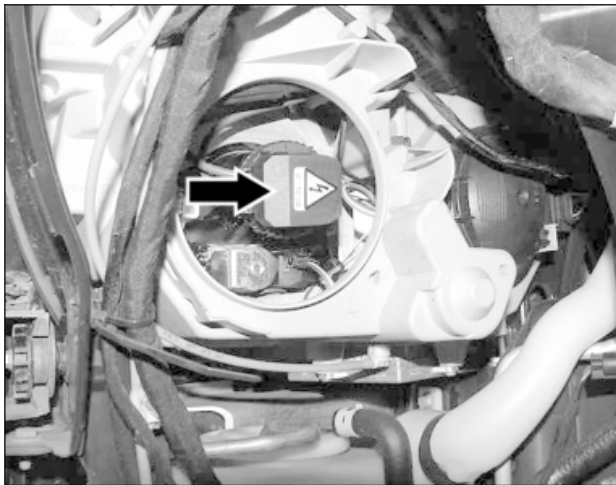

Figure 2

P-B-82.10/376a

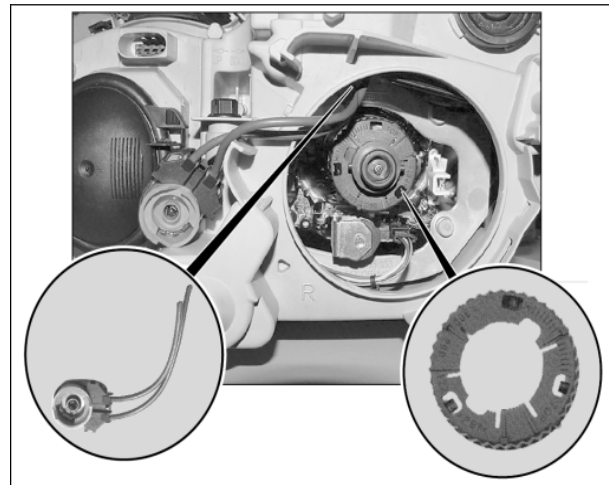

Figure 3

P-B-82.10/376a

- 7.9 Individually cut off the 3 supply lines (red, black and green) as close to the ignition module as possible (Figure 4). This shuts down the ignition module at the headlamp.
- 7.10 Solder the 3 wires from the new ignition module onto the supply lines (Figure 5) using solder connectors A002 546 13 41.

i Note: Be careful not to damage the headlamp with the heat gun.



Figure 4

P-B-82.10/376a



Figure 5

P-B-82.10/376a

- 7.11 Tape over the solder connectors with fabric tape.
- 7.12 Remove the tabs from the 4 holes of the lamp retaining collar A230 826 00 89 (Figure 6, arrows).
- 7.13 Insert burner and attach to lamp retaining collar. Run the ground contact to the bottom (Figure 7).

⚠ Caution! Do not touch the glass portion of the burner with bare hands; otherwise the glass envelope will shatter when energized. Use a non-greasy, soft cloth.

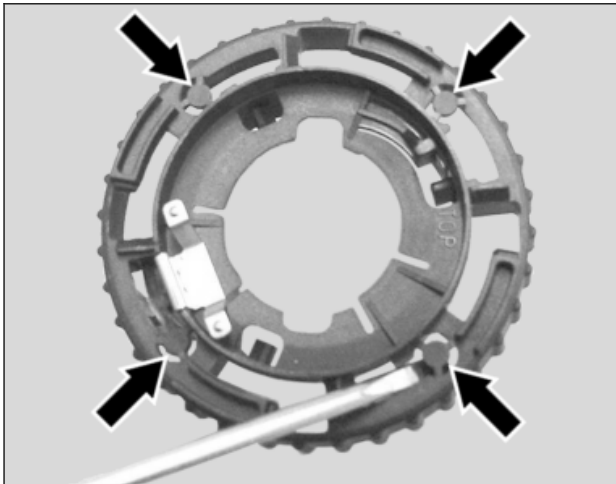

Figure 6

P-B-82.10/376a



Figure 7

P-B-82.10/376a

- 7.14 Push the new ignition module (A002 546 13 41) onto the collar until it snaps in place (Figure 8).

i Note: Ensure the correct installation position (Figure 8, right headlamp A, left headlamp B). Install new housing cover at rear of headlamp.

- 7.15 Test operation of lamp unit
- 7.16 Install removed parts in reverse order.

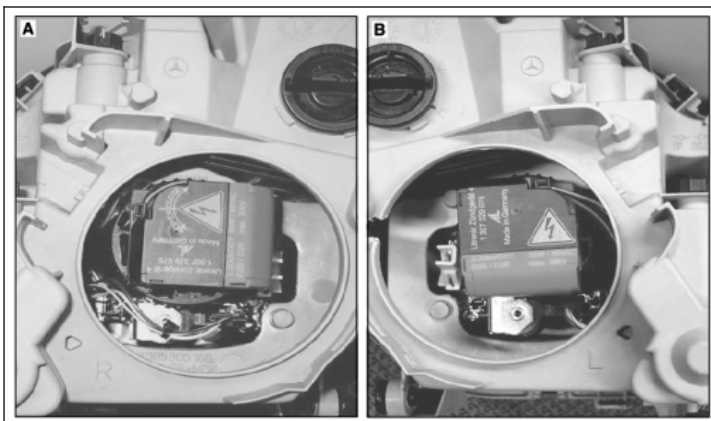

Figure 8

P-B-82.10/376a

8. For 203.7 & 209 models with this complaint and with headlamps manufactured on or before manufacture dates (Figure 1) in the above table, proceed as follow to resolve.

- 8.1 Remove front wheel. Reference WIS document no.AP40.10-P-4050Z.
- 8.2 Remove front fender liner. Reference WIS document no. AR88.10-P-1300P.

- 8.3 Disconnect plug from headlamp.
- 8.4 Unlock and remove housing cover on rear of headlamp unit at the tab and scrap housing cover.
- 8.5 Twist plug on burner to the left and remove.
- 8.6 Cut off burner plug as close to the ignition module as possible (Figure 9) and scrap burner plug.
- 8.7 Individually cut off the 3 supply lines (red, black and green) as close to the ignition module as possible (Figure 10). This shuts down the ignition module at the headlamp.

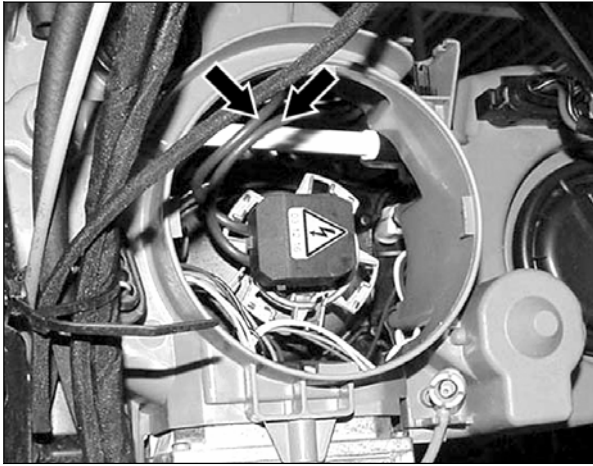

Figure 9

P-B-82.10/376a

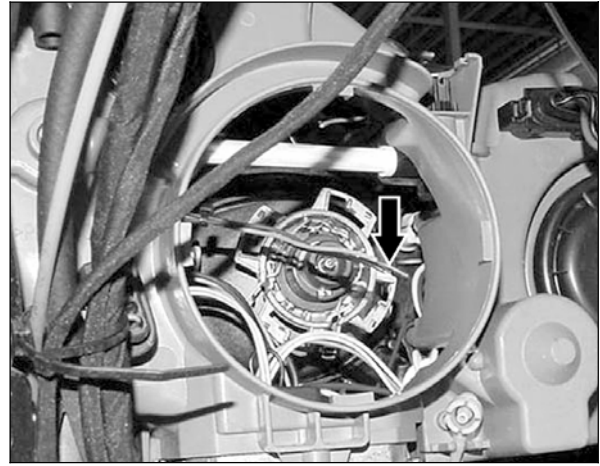

Figure 10

P-B-82.10/376a

- 8.8 Solder the 3 wires from the new ignition module onto the supply lines (Figure 11) using solder connectors A002 546 13 41.

i Note: Be careful not to damage the headlamp with the heat gun.

- 8.9 Tape over the solder connectors with fabric tape.
- 8.10 Insert new ignition module into housing cover (Figure 12) and screw in place.
- 8.11 Screw plug of new ignition module into burner clockwise.
- 8.12 Rotate headlamp housing cover clockwise into place.

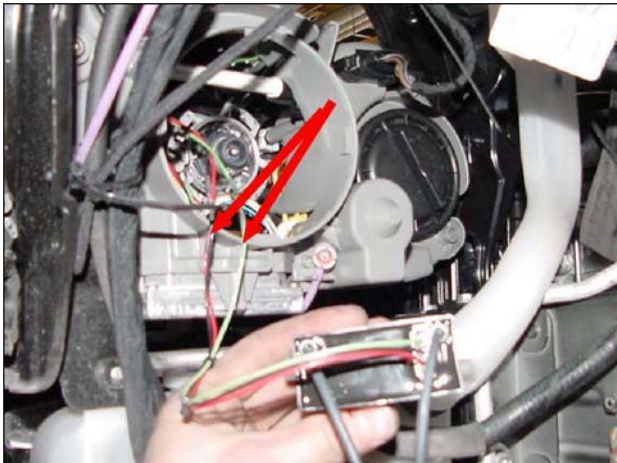

Figure 11

P-B-82.10/376a



Figure 12

P-B-82.10/376a

i Note: The fastening screw must be at the top (Figure 13).

- 8.13 Tighten fastening screw.
- 8.14 Connect headlamp plug.
- 8.15 Test operation of lamp unit.
- 8.16 Install removed parts in the reverse order.

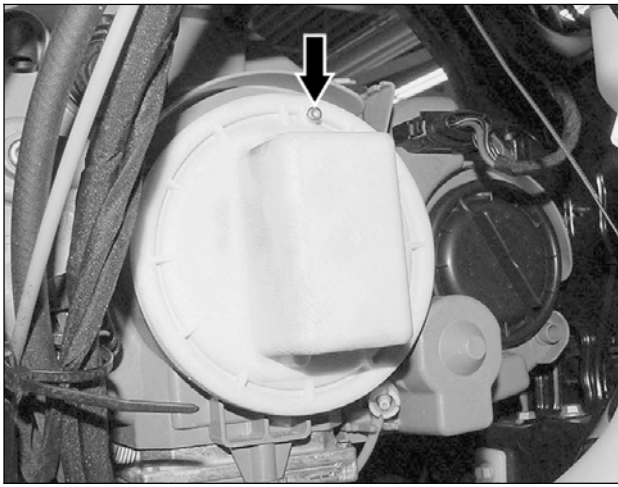

Figure 13

P-B-82.10/376a

Parts Information

Qty.	Part Name	Part Number
1	Xenon Burner (type D2R)	N910139 000000 07
1	Xenon Burner (Bi-Xenon type D2S0)	N910139 000001
3	Solder connector	A002 546 13 41
1	Lamp retaining collar for 203.0 and 203.2 Xenon headlamp	A230 826 00 89
1	Repair kit for 203.0 and 203.2 Xenon headlamp	A203 545 57 28
1	Repair kit for 203.7 and 209 Xenon headlamp	A203 820 11 12 05



Note: The following allowable labor operations should be used when submitting a warranty claim for this repair. This information has been generated on May 23, 2008. Please refer to Netstar → Star TekInfo → Star Time for the most current labor time allowance.

In Case of Warranty

Operation: Short test, perform (54-1011)
 Individual components – outside lighting (specify), test perform (82-0641)
 (82-0641 can only be claimed one time per repair attempt) (According to DTC Codes)
 NOTE: Op Code 82-0641 use is only valid with DTB P-B-82.10/376c
 Light (bulb(s) – in two front exterior lamp units, replace (82-1202)
 Xenon control unit and/or ignition module – one, replace (02-4131)
 Xenon control unit and/or ignition module – both, replace (02-4132)
 Control module – left xenon headlight (after test), replace (82-4636)
 Control module – right xenon headlight (after test), replace (82-4639)
 Control module – both xenon headlight (after test), replace (82-4640)
 Ignition device – both xenon headlight (after test), replace (82-4628)
 Ignition device – right xenon headlight (after test), replace (82-4630)
 Ignition device for (left) xenon headlight (after test) repl. (vehicle w/ ABC). (82-4655)
 Ignition device for (both) xenon headlight (after test), repl. (vehicle w/ ABC) (82-4656)

Damage Code	Operation Number	Time (hrs.)	Model Indicator (s)
Step 1a, 2a, 3a, 4, 5: (Diagnosis)	54 1011	0.3 hrs.	P1, P2, P3, P4, P5, P6, P7, P8, P9, Q1, Q2, Q3, Q4, Q5, R1, R2, R3, R4, S1, S2, S3, S4, S5, S6
	82 0641	1.0 hrs. *	P1, P2, P3, P4, P5, P6, P7, P8, P9, Q1, Q2, Q3, Q4, Q5, R1, R2, R3, R4, S1, S2, S3, S4, S5, S6
Step 2: (If replacing burner) 82126 73	82 1202	0.3 hrs.	S1, S2, S3, S4, S5, S6
		0.4 hrs.	P1, P2, P3, P4, P5, P6, P7, P8, P9, Q1, Q2, Q3, Q4, Q5, R1, R2, R3, R4
Step 4 or 7, 8: (Model 203/209: If replacing xenon headlamp control unit or ignition module) 82119 73 (Step 4) or 82279 74 (Step 7, 8)	02 4131	0.9 hrs.	P1, P2, P3, P4, P5, P6, P7, P8, P9, Q1, Q2, Q3, Q4, Q5
		1.0 hrs.	S1, S2, S3, S4, S5, S6
OR	02 4132	1.4 hrs.	P1, P2, P3, P4, P5, P6, P7, P8, P9, Q1, Q2, Q3, Q4, Q5
Step 4: (Model 230: If replacing xenon headlamp control unit) 82119 73	82 4636	1.6 hrs.	S1, S2, S3, S4, S5, S6
		0.6 hrs.	R1, R2, R3, R4
OR	82 4639	0.6 hrs.	R1, R2, R3, R4
OR	82 4640	0.6 hrs.	R1, R2, R3, R4
Step 6: (Model 230: If replacing ignition module) 82279 73	82 4628	0.5 hrs.	R1, R2, R3, R4
	82 4655	1.6 hrs.	R1, R2, R3, R4
OR	82 4630	0.3 hrs.	R1, R2, R3, R4
OR	82 4656	1.8 hrs.	R1, R2, R3, R4

* Maximum time allowed with a separate time punch. Ensure that punches are labeled as NON time.