

Nm Coolant pump, coolant thermostat

Number	Designation	Engine 272	Engine 273
BA20.10-P-1001-01U	Self-tapping bolt for coolant pump on timing case cover M7 Nm	25	25
BA20.10-P-1002-01U	Bolt for coolant pump on crankcase M8 Nm	20	20

Bolt assignments for coolant pump

i Bolts A: Coolant pump on timing case cover.
 Bolts B and C: Coolant pump on crankcase.

⌚ The tightening sequence given in the following table must be followed to ensure that there are no leaks in the coolant pump.

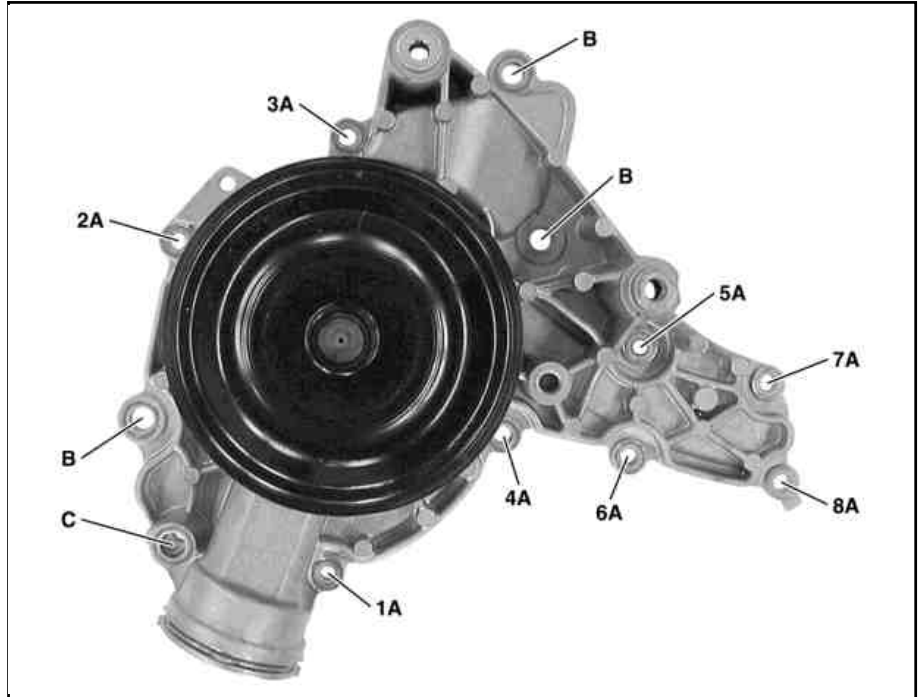

P20.10-2143-06

Tightening sequence and bolt length

Tightening sequence	Bolts
1	1A to 8A (M7×28), tighten in numerically ascending order
2	B (M8×75)
3	C (M8×110)