

MODEL 203 with CODE (612) Xenon headlamp unit

MODEL 209 with CODE (614) Bi-xenon headlamp unit except CODE (P98) Black Series

MODEL 209 with CODE (615) Bi-xenon headlamp unit with integrated curve illumination except CODE (P98) Black Series

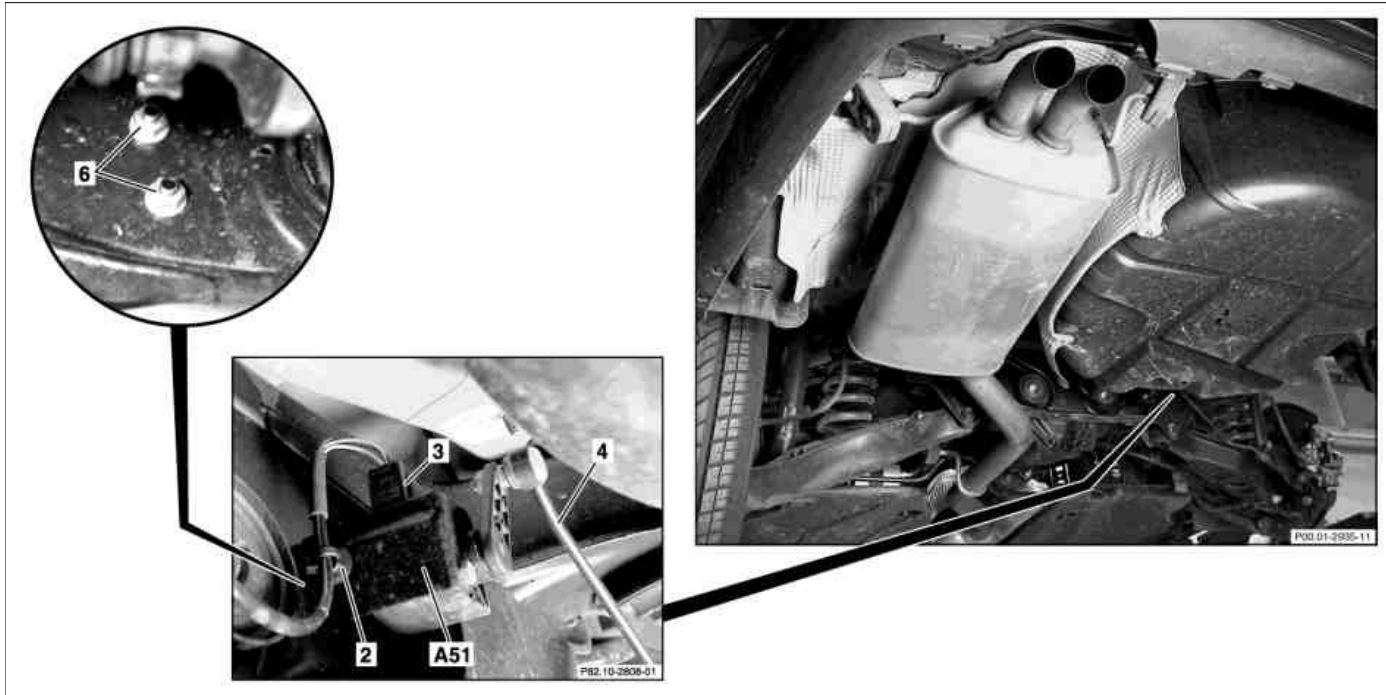

P82.10-2809-09

Shown on model 203

- 4 Rod
- 6 Nut

A51 Headlamp range adjustment rear axle sensor

- 2 Clip
- 3 Electrical connector
- 5 Ball stud
- 8 Bolts
- 9 Bracket
- A51 Headlamp range adjustment rear axle sensor

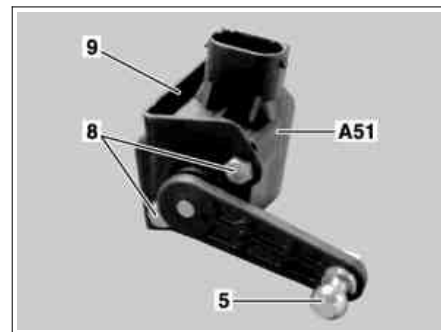

P82.10-2810-01

⚠ ⚠	Remove/install		
⚠ Danger!	Risk of death caused by vehicle slipping or toppling off of the lifting platform.	Align vehicle between columns of vehicle lift and position four support plates at vehicle lift support points specified by vehicle manufacturer.	AS00.00-Z-0010-01A
1	Raise vehicle		AR00.60-P-1000P
2	Push out clip (2)	i Remove clip (2) from rear axle sensor for headlamp range adjustment (A51).	
3	Disconnect connector (3)		
4	Pry off rod (4) from ball stud (5)		
5	Unscrew nuts (6)	i Nuts (6) for bracket (9) to rear axle carrier.	
6	Remove rear axle sensor for headlamp range adjustment (A51)		
7	Unscrew ball stud (5)		
8	Remove bolts (8)		

9	Remove bracket (9)	i Remove bracket (9) from rear axle sensor for headlamp range adjustment (A51).	
10	Install in the reverse order		
11	Check headlamp setting and correct if necessary Check and correct headlamp adjustment		AP82.10-P-8260P