

**Modification notes**

3.2.11	Replace special tool 602 589 04 63 00 and 602 589 04 60 01 by special tool 271 589 10 63 00		
--------	---	--	--



602 589 00 98 00

Case

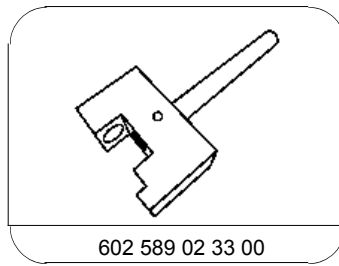

602 589 02 33 00

Chain separating tool

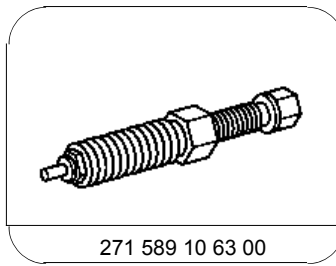

271 589 10 63 00

Thrust spindle

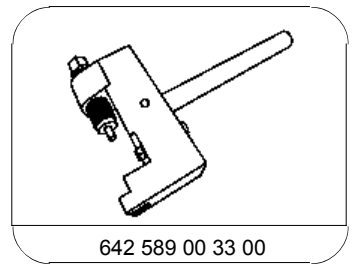

642 589 00 33 00

Riveting tool

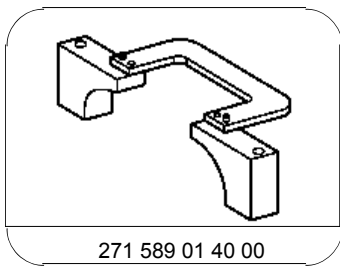

271 589 01 40 00

Holding device

- 1 Mount retainer (1) onto the cylinder head.
- 2 Cover timing case recess and cylinder head with clean rag.



P05.10-2174-11

- 3 Engine 271.9: Assemble chain separating tool (2) and pressure screw (3).

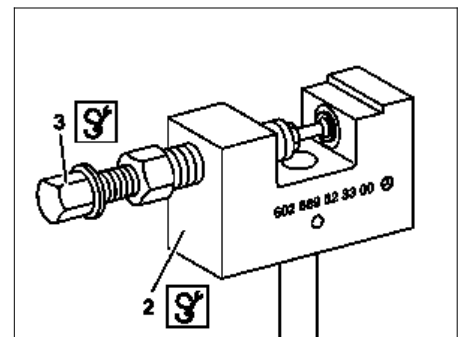

- 4.1 Engine 271.9: Place chain breaker tool (2) with thrust spindle (3) on timing chain (4).  
 ⓘ When fitting the chain separating tool (2) onto the timing chain (4,) ensure that the pressure pin of the pressure screw (3) fits closely at pin of chain link.
- 4.2 Engine 271.8: Place rivet press tool on timing chain (4) between support for the slide rail and camshaft sprocket for intake camshaft.  
 ⓘ When fitting the rivet press tool onto the timing chain (4,) ensure that the pressure pin of the pressure screw (3) fits exactly at pin of chain link.
- 5 Screw in pressure screw (3) and separate timing chain (4).  
 ⚠ Do not allow pin which is pushed out to drop into crankcase. Parts which have dropped into the crankcase, must be removed.
- 6 Remove thrust spindle (3) and chain breaker tool (2) or rivet press tool.

