

AR01.30-P-5800-07QA	Tightening specifications for cylinder head bolts		
---------------------	---	--	--

Nm Cylinder head

Number	Designation	Engine 271
BA01.30-P-1002-01J	Bolt, cylinder head	M10 Stage 1 Nm 45
		Stage 2 Δ° 90
		Stage 3 Δ° 90
		See picture -

Nm Crankcase, timing case cover, end cover

Number	Designation	Engine 271
BA01.40-P-1002-01G	Bolt, cylinder head to timing case cover	Stage 1 Nm 20
		Stage 2 $^\circ\Delta$ -

Tightening instructions/Bolt assignment

- A Cylinder head bolts M10x165
- B External Torx bolt M8 x40 (to timing case cover)

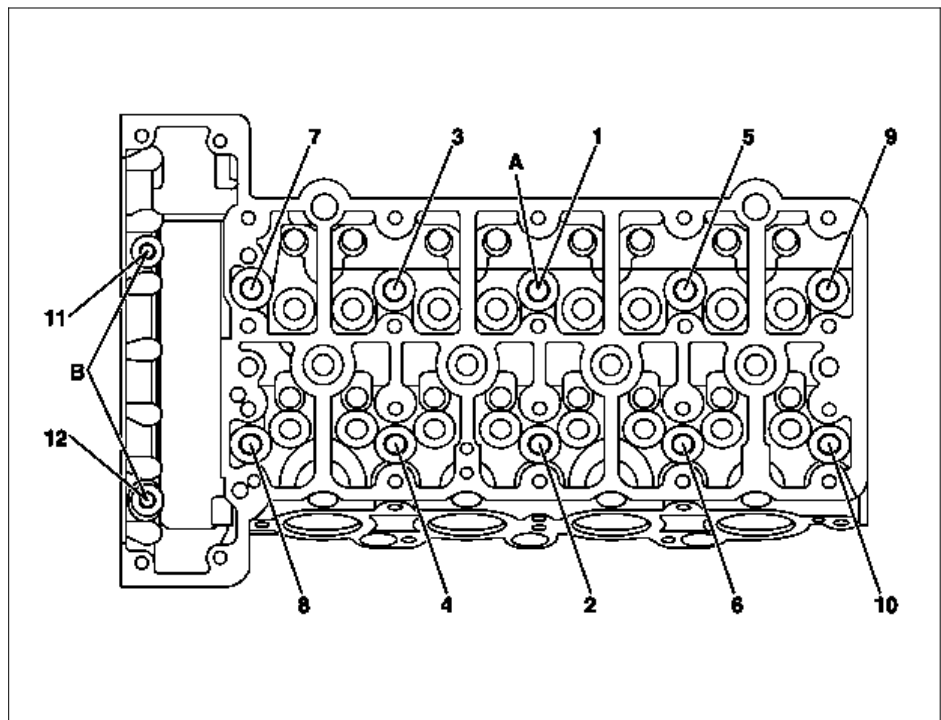

P01.30-2130-06