



C-Class Saloon and Estate

Mercedes-Benz

“In driving refinement, design or safety – the C-Class is a genuine Mercedes. Experience it for yourself.”

Dr Dieter Zetsche

Contents

The C-Class	3	My C-Class	64
Agility	12	Design and equipment lines	66
BlueEFFICIENCY	14	Standard equipment	68
Diesel engines	16	ELEGANCE	74
Petrol engines	18	AVANTGARDE	80
Transmissions	22	AMG Sports package	88
Suspension	24	Equipment	94
4MATIC	26	Standard equipment	94
Comfort	30	Light-alloy wheels	96
Interior	30	Audio and communication systems	100
Cockpit	32	Optional extras	101
Seating comfort	34	Standard equipment/optional extras for estate	104
COMAND APS	36	designo	106
Ride comfort	38	Genuine accessories	110
Load compartment	40	Colours and materials	114
Safety	44	Paintwork	116
Integral safety concept	44	Upholstery and leather	118
AMG	56	Trim parts	120
		Combination options	121
		Technical details	122
		Saloon	122
		Estate	126
		Services	130

Get a new feel for the road

The C-Class. Agility and effortless superiority

Grey asphalt may not be one of life's most inspiring sights, but for over 120 years now, our vehicles have shown that it can give drivers a lot of fun. Reason enough, we thought, to go a step further and offer a new interpretation of driving pleasure. The result is the C-Class. Available as a saloon or an estate, it allows you to experience the road as never before. Few cars can compete with its ability to adjust so many facets of its character – from the interior to the drive technology – so quickly and precisely in response to external conditions and your own particular needs.

The advanced technology for the C-Class includes the standard-fit AGILITY CONTROL package with selective damp-

ing as well as the optional Dynamic Handling package with a sports mode which allows you to adjust the vehicle's handling at the touch of a button. A wide range of engines (including a number of uprated units) means that the C-Class can be specified to meet just about any performance requirements while the estate offers the ideal combination of functionality and flexibility. Both models feature fine materials and an elegant design, creating an even more compelling interior ambience (whether this reflects a more sports-oriented character or a particular emphasis on comfort is entirely up to you). As you will see, in terms of its external appearance, too, the C-Class has, quite literally, several faces.



A mark of personality

The design of the C-Class AVANTGARDE

The C-Class impresses, both inside and out, with its distinctive design, spaciousness, high-quality materials and wide choice of paint finishes and upholstery patterns. What's more, you can choose which aspect of your C-Class you would like to highlight. The AVANTGARDE design and equipment line emphasises the car's sporty side. The dominant star in the radiator grille makes a powerful statement, while the chrome band which runs right around the body accentuates the taut lines of the C-Class.

A sure sign of style

The design of the C-Class ELEGANCE

The ELEGANCE design and equipment line brings the refinement and comfort of the C-Class to the fore. The characteristic star features as a free-standing element on the bonnet and the different chrome trim parts around the vehicle give the C-Class a particularly impressive presence. Tone-in-tone colour schemes contribute to the warm, pleasant atmosphere of the interior. Convex, chromed badges on the front wings designate the ELEGANCE and AVANTGARDE design and equipment lines which build on the classically stylish look of the standard-equipment version of the C-Class.











GUSBERG VI





The C-Class



Your most enjoyable drive ever. Each time you get in

An agile look - right down to the last centimetre

The C-Class is a pleasure to behold: its taut lines lend it an air of effortless superiority while the wide radiator grille and distinctive rear section announce a vehicle with a real presence and a dynamic personality. But these compelling looks are only part of the story.

The C-Class is equipped with many innovative technical features which deliver a driving experience that is unique in this class. Think ease and confidence. Among the highlights is the AGILITY CONTROL package. This comprises AGILITY CONTROL suspension with a selective damping system which automatically adjusts the suspension tuning in accordance with the condition of the road - giving you a consistently high level of driving enjoyment.

As an option, you can order the Dynamic Handling package with its special sports mode which allows you to choose a particularly sporty suspension response or a distinctly comfortable one at the touch of a button.

And for a perfect driving experience not only on any road, but in any weather, too, you can choose the optional 4MATIC all-wheel-drive system. It is available for the C 300 and C 350 petrol-powered saloon models and for the C 250 CDI BlueEFFICIENCY and the C 350 CDI BlueEFFICIENCY diesel versions of the saloon and the estate. As well as improving grip on wet roads when accelerating, for example, 4MATIC offers a noticeably more dynamic driving experience in the dry, too.

BlueEFFICIENCY – innovations for efficient mobility

We do not pay lip service to protection of the environment. It's a matter close to our hearts. As the inventor of the motor car, Mercedes-Benz has a special responsibility – one we have undertaken with all our might for many years. We can already offer you 66 models that place far less of a burden on the environment – without having to compromise on safety, comfort and driving enjoyment.

Our BlueEFFICIENCY concept comprises innovations for efficient mobility as well as optimised processes all the way along the value chain. They involve different approaches, but they all have a common goal: to make your individual mobility as sustainable as possible.

The BlueEFFICIENCY measures – the Mercedes-Benz efficiency package. The BlueEFFICIENCY measures are comprehensive vehicle optimisations which save fuel and, therefore, ease the burden on the environment. Each model combines the most efficient engine with optimal aero-

dynamic and energy-management measures to minimise fuel consumption. Such measures include intelligently controlled ancillaries, tyres with optimised rolling resistance, the ECO start/stop function, lightweight components and an aerodynamically optimised body design. All in all, these measures allow substantial savings to be made: fuel consumption and, therefore, CO₂ emissions are reduced by up to 23 %.

BlueTEC – the clean diesel. Mercedes-Benz has brought to market BlueTEC technology for diesel engines based on common-rail direct injection



The BlueEFFICIENCY measures bring about a substantial reduction in fuel consumption and CO₂ emissions

(CDI). It combines optimised combustion with a modular emission-control system, all of which makes BlueTEC an exceptionally clean diesel technology. Not only does it remove up to 95 % of the particulate from the exhaust gases, it also reduces nitrogen oxides by up to 90 %. All that remains is water, harmless nitrogen and the satisfying feeling of having helped to ease the burden on the environment.

HYBRID – the intelligent combination of petrol and electric drive. A well-established team makes a lot of things easier. And this is certainly true



BlueTEC filters out up to 95 % of the particulate and converts up to 90 % of the nitrogen oxides into harmless nitrogen

in the case of HYBRID technology. During braking, the electric motor supplies the battery with kinetic energy. When needed, this energy is forwarded to the electric drive, which assists the petrol engine when the car is accelerating. What's more, the ECU shuts off the petrol engine when the speed falls below 15 km/h. In this way, a HYBRID can reduce fuel consumption by up to 20%. So it looks after the environment as well as your bank balance. Perfect teamwork, you might say.



HYBRID technology reduces fuel consumption by up to 20%

BlueTEC HYBRID – clean diesel combined with electric drive. BlueTEC HYBRID technology marries the benefits of HYBRID technology with those of BlueTEC technology: during braking, the kinetic energy is converted into electrical energy, which can be re-used when required. At the same time, the BlueTEC technology cleans the exhaust gases and removes most of the pollutants.

Innovative drive systems that break new ground. Concept BlueZERO F-CELL, E-CELL and E-CELL PLUS. Mercedes-Benz has developed three fur-



BlueTEC HYBRID combines clean diesel technology with electric drive, and will be available from 2012

ther drive concepts with an electric motor and a battery for storing energy as part of its close-to-production Concept BlueZERO: E-CELL with an electric motor, which only draws its energy from the battery; E-CELL PLUS with a battery and an internal combustion engine (Range Extender); and F-CELL with an additional fuel cell for generating power.

But that is not all: under the banner “Design for Environment”, we also look at a vehicle's entire lifecycle – from planning to recycling. The same applies to the building and running of new factories. In addition, Mercedes-Benz is involved in the development of alternative fuels and carries out research in the field of bionics. In short, BlueEFFICIENCY is good news for both you and the environment.

Further information about our comprehensive measures can be found at:

www.mercedes-benz.com/blueefficiency



Engines with the power to move you

The C-Class diesel models with common-rail technology and a particulate filter

Six efficient and powerful CDI engines are available for the C-Class. The C 350 CDI BlueEFFICIENCY boasts a six-cylinder common-rail unit with an output of 170 kW which accelerates the car from 0 to 100 km/h in 6.4 seconds.

Drivers who are particularly environmentally aware will be delighted by the C 200 CDI BlueEFFICIENCY, C 220 CDI BlueEFFICIENCY and the C 250 CDI BlueEFFICIENCY. The C 200 CDI BlueEFFICIENCY boasts superb output and high torque courtesy of its sophisticated technology. The C 200 CDI BlueEFFICIENCY develops 100 kW. The C 220 CDI BlueEFFICIENCY achieves an impressive 125 kW with a torque of up to 400 Nm. And the C 250 CDI BlueEFFICIENCY boasts an output of 150 kW at as much as

500 Nm. Both models are especially efficient and very easy on the environment, in accordance with the EU5 emissions standard. Integrated in the vehicles is an entire package brimming with intelligent measures for reducing weight, air and rolling resistance, plus an optimised energy management system which considerably reduces fuel consumption as well as CO₂ emissions.



Numerous efficiency-enhancing measures in the BlueEFFICIENCY models ensure reduced fuel consumption and lower CO₂ emissions

It's more than engineering. It's performance art

The dynamic 4-cylinder petrol engines

You can choose between eleven different petrol engines for the C-Class; the range begins with five 4-cylinder models. The C 180 CGI BlueEFFICIENCY has an output of 115 kW and a maximum torque of 250 Nm between 1600 and 4200 rpm while the C 200 CGI BlueEFFICIENCY delivers 135 kW and 270 Nm. The C 250 CGI BlueEFFICIENCY is the most powerful achieving no less than 150 kW and 310 Nm.

And the acceleration is impressive right from the start. The C 180 CGI BlueEFFICIENCY requires merely 9.0 seconds, the C 200 CGI BlueEFFICIENCY 8.2 seconds, to accelerate

from 0 to 100 km/h, with top speeds of 220 km/h and 232 km/h respectively. The C 250 CGI BlueEFFICIENCY is even faster reaching 100 km/h in 7.4 seconds with a top speed of 240 km/h.

Good performance is combined with low fuel consumption thanks to BlueEFFICIENCY technology. The extensive range of intelligent measures considerably reduces fuel consumption on every trip. The refined engines don't just distinguish themselves in terms of acceleration, but will also save you money at the filling station.



If it all went too fast for you out on the road, catch up on the facts and figures here

The V6 petrol engines: the strong, silent types

The 6-cylinder engines in the C 300, C 350 and C 350 CGI BlueEFFICIENCY are the very embodiment of refined power. The maximum torque of 300, 350 and 365 Nm respectively is available over a particularly wide engine speed range, ensuring that impressive power reserves are ready for action in any driving situation you may find yourself in. Another hallmark of the V6 engines is their exemplary utilisation of fuel thanks to four variable camshafts that can be steplessly controlled as required, meaning that precisely the correct amount of fuel is called up for the driving situation in hand.

The C 300 develops 170 kW, whilst the C 350 puts more than 200 kW on tap. The C 350 CGI BlueEFFICIENCY with direct petrol injection even consumes ten percent less fuel than comparable 6-cylinder petrol vehicles – and that with an impressive 215 kW, not to mention an acceleration time on a par with that of a sports car: 0 to 100 km/h in 6.2 seconds.

The versions equipped with V6 engines, which use fuel particularly sparingly, can be identified externally by the dual-flow exhaust system.

C 350

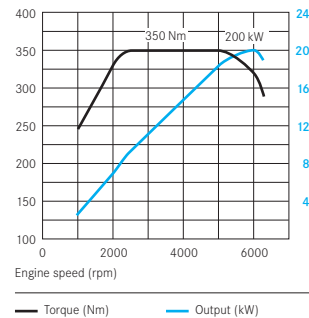

The C 350 with a maximum torque of 350 Nm and an output of 200 kW



We've stepped up a gear or two so that you can enjoy faster shifting

Transmission technology in the C-Class

The C-Class is fitted as standard with a 6-speed manual transmission with very short shift throw which makes gear changes a joy. The ratios are specially tuned to the model's high torque. All 4-cylinder models are also equipped with a gearshift recommendation for optimal fuel efficiency, while all C-Class models boast a display of the current fuel consumption as standard.

A 5-speed automatic transmission is available as an option for some of the 4-cylinder models. The highlight of our transmission range, the 7G-TRONIC automatic transmission, is standard in the C 350 CDI BlueEFFICIENCY, C 350, C 350 CGI BlueEFFICIENCY, C 63 AMG as well as the 4MATIC models and optionally on the C 300. The seven forward gears permit optimum rev levels at all times and make for almost imperceptible gear changes. 7G-TRONIC can also skip individual gears when downshifting for quicker bursts of speed.



A nice touch: if your car is fitted with an automatic transmission and you want to change up or down a gear manually, simply nudge the selector lever to the right or left



Even more compelling driving at the touch of a button

The Dynamic Handling package for the C-Class

The dynamic characteristics of the C-Class set the standard by which all vehicles in this segment are judged – a standard which is raised even further by the optional Dynamic Handling package with a sports mode. A touch of a button is all it takes to choose a distinctly comfort-oriented driving experience or a compellingly sporty one. With sports mode selected, the system adjusts not only the firmness of the damping, but also sharpens the accelerator response. Assuming, of course, that you are in the mood for it. Otherwise, you can simply choose the comfort mode and enjoy a particularly smooth and comfortable ride.

Whatever the selected mode, the electronically controlled damping system constantly adjusts to the driving situation and the condition of the road. The result is a smoother ride, increased handling safety and, above all, greater agility. The Dynamic Handling package includes innovative

speed-sensitive sports steering which uses a modified steering response map to deliver a particularly sporty feel. This sensation is complemented by the lower-slung chassis (15 mm lower) which makes fast bends even more enjoyable.



Dynamic Handling package: the Dynamic Handling package allows you to match the C-Class to your mood. A touch of a button is all it takes to give the vehicle a distinctly sporty handling response. Vehicles equipped with 7G-TRONIC benefit from an additional, noticeable reduction in shift times



The C-Class makes the best of bad weather

High traction with 4MATIC all-wheel drive

When contending with loose gravel, snow or challenging inclines, 4MATIC all-wheel drive distributes the engine power to the wheels that need it most. It interacts intelligently with the Electronic Stability Program ESP®, acceleration skid control ASR and the 4MATIC-specific electronic traction system 4ETS to increase both directional stability and traction – particularly where road conditions are difficult.

4MATIC permanent all-wheel drive is available for the C 250 CDI BlueEFFICIENCY, C 350 CDI BlueEFFICIENCY, C 300 and C 350 Saloons as well as for the C 250 CDI BlueEFFICIENCY and C 350 CDI BlueEFFICIENCY Estate versions. All 4MATIC models are equipped as standard with the 7G-TRONIC automatic transmission.

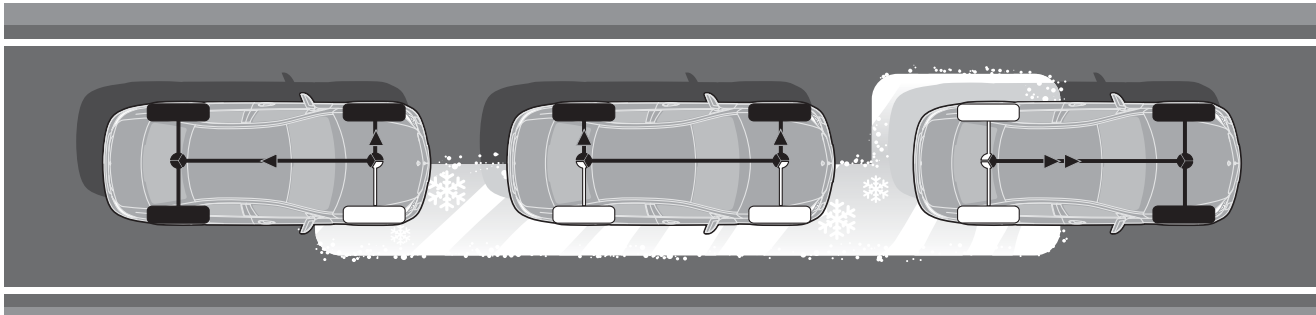

4ETS: in the 4MATIC models the electronic traction system ETS is adapted to the special requirements of all-wheel drive. It automatically diverts the drive torque to the wheels with the best grip





C350



S ON3811





Why long trips are going to seem much too short from now on

The interior of the C-Class

With its soft materials, fine trim parts and more space than ever, the interior of the C-Class is particularly inviting. Shoulder and elbow room has been increased, and rear passengers will also quickly feel at home thanks to their increased legroom. The exceptional ambience of the interior is heightened further by numerous attractive design details with chrome, wood or aluminium trim, depending on the model and your preferences. With a wide range of optional equipment highlights to choose from, including the panoramic sliding sunroof, which features a particularly large glass area, driving the C-Class is a joy that, quite literally, knows no bounds.



Take a seat: The firmness of the lateral and upper-leg support areas of the seat cushions helps to keep you fresh and alert when on the move



You've worked hard enough. Now it's our turn

Stress-relieving comfort in the C-Class

A driving environment which allows you to concentrate on the task in hand is not just a luxury, it is also a major safety feature. It all starts with the well-designed driver's area. The dashboard allows you to take in all the necessary information at a glance. The instrument cluster, with its three round displays, is situated in the driver's immediate field of vision and provides information about key operating parameters. Depending on the equipment version, you can use the multifunction steering wheel for easy and convenient control of various features while keeping both hands on the steering wheel. And with the optional KEYLESS-GO function, you can drive off without even having to turn an ignition key.

A comfortable travelling environment comes courtesy of THERMATIC 2-zone automatic climate control which is fitted as standard in the C-Class. As an option, you can order

THERMOTRONIC 3-zone luxury automatic climate control which, among other things, allows the temperature of the rear section of the passenger compartment to be set independently as well.



An easy touch: the instruments and systems have intuitive controls. The press of a button is all it takes to adjust audio settings, in-car entertainment selections or, here, the temperature

Soft on the outside, firm on the inside

The secrets of exceptional travel comfort

Equipped on the driver's side with a lumbar support for enhanced lower-back comfort, the ergonomic front seats are electrically adjustable for cushion height and backrest angle. These settings, in combination with others such as the steering wheel position, head restraint height and exterior mirror position, can be stored by means of the optional Memory package. This allows three different configurations to be recalled at the touch of a button.

Also available as an optional extra, the multicontour seat has adaptive air chambers for even greater comfort.

As a result, you can adjust the side bolsters of the seat cushion and backrest as well as the lumbar support to meet your individual comfort and health requirements.

If it's the dynamic side of the C-Class that interests you most, there's the optional AMG Sports package which includes seats with more pronounced contours for even greater lateral support. Other optional extras include leather upholstery. Depending on the line, this is available in the form of either ARTICO man-made leather or genuine leather in a choice of attractive colours.







Typical Mercedes: a navigation system that's a real turn for the better

The COMAND APS multimedia navigation system

The optional COMAND APS multimedia system guides you directly to your destination, helping you to arrive fresh and composed. It combines audio, telephone and navigation functions. Thanks to its interface, COMAND APS is now more intelligent and user-friendly than ever – despite having considerably extended functionality.

The pivoting 7-inch display with graphic elements and colours is now at the same level as the instrument cluster and is therefore ideally positioned in the driver's field of vision. COMAND APS can be controlled either via an input array in the centre console or via the controller which falls conveniently to hand in front of the armrest. Moreover, all key functions can now also be called up by means of a voice-recognition function: the destination input section of the navigation system has whole-word recognition capability for all place names and road names; a stored telephone number can be dialled simply by saying the name associated

with it and you can even set the system up to read out your text messages. Bluetooth® functionality is also integrated to allow safe hands-free mobile phone operation and the DVD player is compatible not only with video and audio DVDs, but with CDs and MP3 files too. Up to 1500 MP3 music tracks can be stored on the hard disc of the navigation system.



All at your fingertips: the armrest is designed in such a way that the controller automatically falls to hand. It offers a particularly fast, easy and intuitive way of adjusting the full range of COMAND APS settings



A chauffeur-driven feel

The C-Class: setting the benchmark for comfortable suspension and low noise levels

The C-Class has always been synonymous with outstanding ride comfort. With every new model generation, the aim of our engineers is to raise the standard yet again. This is why the C-Class features a selective damping system. The standard-fit AGILITY CONTROL package automatically adjusts the dampers at each wheel to a harder or softer setting according to the current driving situation, ensuring a significantly smoother ride than conventional dampers, especially on poor road surfaces.

Low interior noise levels are a prerequisite for a relaxing driving experience. To eliminate wind noise from the C-Class interior even more effectively, we have optimised the shape of countless bodywork details and further improved the sound insulation.

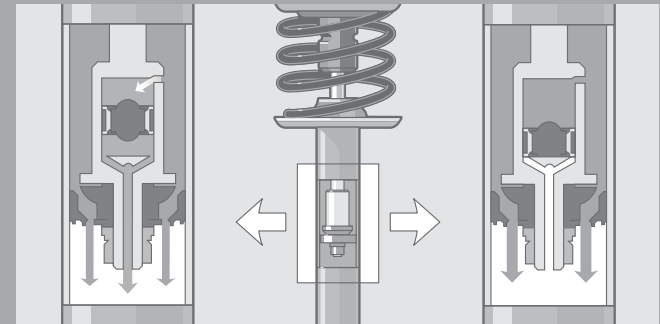

Selective damping system: softer shock absorber characteristics ensure an extremely smooth ride in normal mode. For dynamic driving the full damping force is made available to stabilise the vehicle



If you need more space, we have the real estate

Simply more possibilities

Every day brings its challenges, be they large or small, personal or professional. It is only natural, therefore, that anyone who wants to be prepared for any situation should set particularly high standards when it comes to choosing an estate, not least with regard to the variability of the load compartment. So we took special care to address these needs comprehensively during the development of the C-Class Estate – with the handy stowage nets, the 910 to 1500-litre load capacity (particularly impressive in this segment) and the EASY-PACK load-securing kit. All the details have been fully thought-out and are geared to the same objective: ensuring your comfort.

The C-Class Estate also impresses with its extremely high payload of up to 530 kg¹ as well as its remarkable towing capacity of up to 1800 kg. What's more, when you make use of the latter, you benefit from the additional safety offered by the trailer stabilisation functionality of the vehicle's ESP[®] system. A range of options, including automatic opening/closing for the tailgate and a new type of self-levelling suspension for optimum load compensation, enhances the everyday practicality of this all-rounder even further.

¹As per DIN





THE INTEGRAL SAFETY CONCEPT
FROM MERCEDES-BENZ

A high-angle, close-up photograph of a brown leather-bound book. The book is positioned diagonally on a dark, brushed metal surface. The cover is made of a textured, dark brown leather with visible stitching along the edges. The text 'THE INTEGRAL SAFETY CONCEPT' is embossed in a serif font on the upper half of the cover, with 'FROM MERCEDES-BENZ' below it. The book's spine is visible on the left, and the edges of the pages are seen at the bottom right. The lighting creates soft shadows and highlights the texture of the leather and the metal surface.

A theory which can save lives in practice

The integral safety concept from Mercedes-Benz

Few, if any, fields of activity inspire us to produce such consistently impressive results as researching new safety technologies. As early as the 1950s, we passed an important safety milestone when legendary vehicle safety pioneer Béla Barényi invented the passenger safety cell.

This era also saw revolutionary ideas put forward by many others – such as Rolf Maier. In order to be able to study the crash performance of steering and restraint systems quickly and cost-effectively, Maier and his engineer colleagues designed and built a special sledge which was to be driven into a wall at high speed. When they needed to create a crumple zone, the team came up with a simple, yet brilliant solution: gherkin tins from the staff restaurant – a typical example of the creative spirit which characterised this pioneering time.

Much as we like to reflect on the past, though, our focus has always been firmly on the future. The best example is our vision of accident-free driving, which is nearer today than ever before thanks to PRO-SAFE™. This integral safety concept from Mercedes-Benz divides automotive safety into four phases.

To ensure a safe journey throughout, the vehicle helps the driver to identify critical situations promptly and handle them better. In the second phase, where a risk has been detected, numerous preventive measures can be activated to reduce the risk of injury. In the event of an accident, the occupants can benefit from effective, individualised protection provided by the comprehensive range of passive safety systems. Finally, the fourth component comprises the phase after the accident when further measures come into play – to make the task of the rescue services easier, for example.

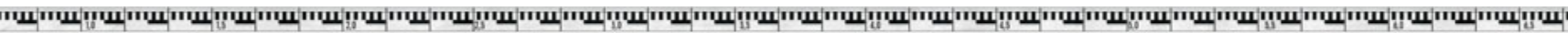

Focusing on helping you to stay focused

Drive more safely, and avoid dangers before they have a chance to develop

The majority of accidents start long before the actual collision: with a lapse in concentration, poor visibility or an unexpected hazard. The C-Class is therefore fitted with safety systems which promote relaxed motoring and help you to bring critical situations under control.

For example, the COMAND APS multimedia system as well as the voice-operated control system LINGUATRONIC, both of which are available as options, allow you to keep both hands on the steering wheel. When driving, you can also count on over 60 electronic support systems. Some are designed to alert you in the event of a problem – the tyre pressure loss warning system, for example. Others are there to provide active assistance, such as the Electronic Stability Program ESP®, Brake Assist (BAS) or the ESP® trailer stabilisation. The ESP® and BAS sensors can detect hazardous driving situations – such as pronounced oversteer or understeer, dramatic steering movements, emergency and panic braking – and can assist the driver accordingly.

You are also kept informed about the safety status of your passengers. The standard belt status display for the rear seats in the instrument cluster gives you a visual signal if a passenger has forgotten to belt up.

Driving in the dark becomes an experience to relish with the optional Intelligent Light System, based on the bi-xenon headlamps. It automatically adapts the low-beam lights to the given driving situation, providing broader illumination on country roads and better long-range visibility on motorways compared with conventional low-beam lights. The Intelligent Light System also includes enhanced fog lamps, which significantly improve illumination of the driver's side of the road. Other components of the Intelligent Light System include the active light and cornering light functions. With these, the headlamps follow your steering movements, thus lighting up bends in the road more effectively. And, not least, the LED daytime driving lights enhance safety even more.

Some hazards arise in next to no time. Some protective systems are even faster

The PRE-SAFE® anticipatory occupant protection system

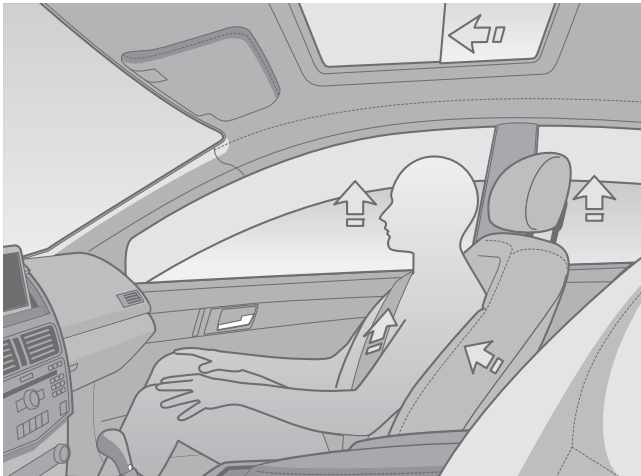

Mercedes-Benz presented PRE-SAFE® in 2002 with one particular thought in mind: the valuable seconds which precede an accident usually elapse unused. The optional PRE-SAFE® system is designed to make effective use of them. The ESP® and BAS sensors identify potentially dangerous situations such as strong oversteer or understeer, critical steering movements, panic braking or emergency braking.

PRE-SAFE®: if there is an immediate danger of an accident occurring, the optional PRE-SAFE® system can tauten the seat belts, close the side windows and the optional sliding sunroof or panoramic sliding sunroof and move the front passenger seat into a more favourable position (in conjunction with electrically adjustable seats and Memory package)





There's more. PRE-SAFE® electronically evaluates this information and, when faced with situations which are typically associated with hazards, it triggers precautionary measures to protect the occupants - including automatic tautening of the front seat belts, automatic repositioning of the front passenger seat (provided it is electrically adjustable and equipped with the memory function) and automatic closure of the side windows and the optional sliding sunroof or panoramic sliding sunroof.

In the event of emergency braking, the adaptive brake lights are also activated, their flashing mode providing more of a warning to traffic behind than conventional brake lights.

If it comes to the crunch, you can trust Mercedes to cushion the blow

Restraint systems and the passenger safety cell can protect you and others effectively in an accident

Numerous occupant protection systems can significantly reduce the risk of injury in an accident. In the event of a rear-end collision, for example, sensors cause the standard-fit NECK-PRO head restraints for the driver and front passenger to deploy in a matter of milliseconds to reduce the distance between the seat occupant's head and the head restraint.

The C-Class is equipped with belt tensioners on the front and outer rear seats, plus numerous airbags, including two-stage driver's and front passenger airbags, a kneebag for the driver, front sidebags, and windowbags whose

protection zone covers virtually the entire area of the side windows. The sidebags and windowbags are also triggered by pressure sensors: if the door deforms in a side-on collision, the increase in air pressure between the outer door panels and the interior of the door is registered by the pressure sensors, which assist the control unit in deploying the airbags.

And protection also extends to other road users, thanks to features such as smooth body surfaces with a generous degree of predefined yield.

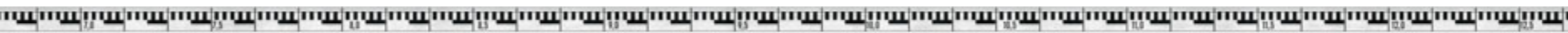

Your Mercedes may have been immobilised, but that doesn't mean it can't still help you

Safety after the event: helping to minimise further damage and speed up the rescue effort

In order to prevent further damage being caused following an accident and to assist with the task of rescuing the occupants, the C-Class is able to take various measures depending on the type and severity of the accident: the engine can be turned off automatically and the fuel supply cut. The hazard warning lights and emergency interior lights can be activated automatically, the side windows partially lowered, if necessary, and the doors automatically unlocked. To complete its holistic safety philosophy, Mercedes-Benz has also published multi-lingual rescue guidelines (accessible online worldwide at www.mercedes-benz.com/rescue-guidelines) as an additional aid for the emergency services.

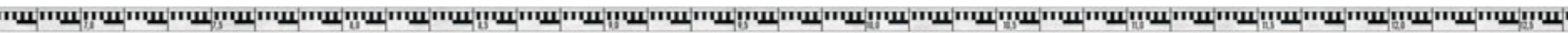
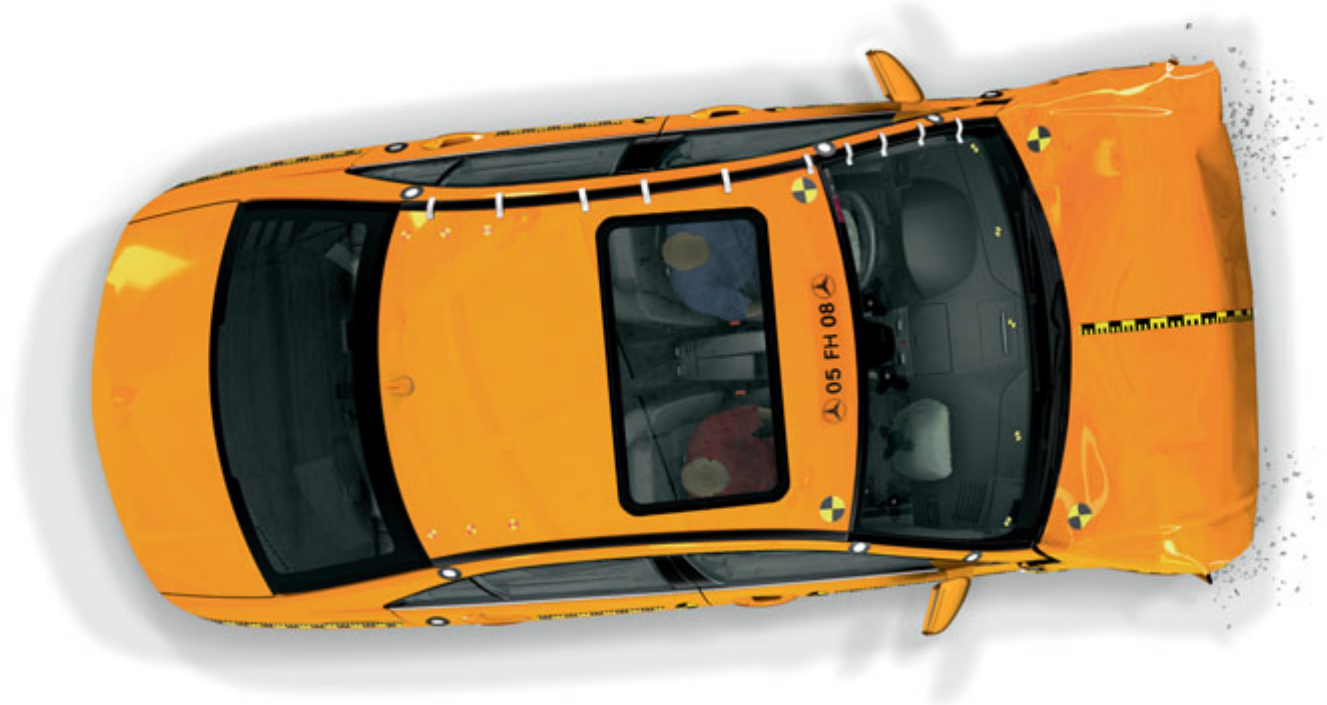





M.F.F.

Hellelyst



Steng hovedkyl
for ombordkjø

Please close
valve before



The sportiest C-Class of all time

The C 63 AMG

A 6.3-litre naturally aspirated V8 engine, 336 kW, 600 Nm of torque, 0 to 100 km/h in 4.5 seconds (estate: 4.6 s), top speed 250 km/h – the specification and performance data of the C 63 AMG speak for themselves. But the only way to really appreciate the calibre of this exceptional vehicle is to drive it. The fifth generation of the AMG C-Class offers a perfect blend of extraordinarily impressive performance and expressive design. Outstanding power and agility are ensured by the combination of the AMG V8 engine and the perfectly matched AMG sports suspension with a wider front axle and AMG speed-sensitive sports steering. The 7-speed AMG SPEEDSHIFT PLUS 7G-TRONIC automatic transmission ensures optimum delivery of engine power to the road, enhances driving dynamics with its ultra-smooth downshifts and makes for an even more enjoyable drive with its double-declutching function. The new, specially optimised three-stage Electronic Stability Program

ESP® and the AMG high-performance brake system also play key roles in delivering a safe and enjoyable driving experience. But the really great thing about the C 63 AMG is that it is a genuine Mercedes-Benz in every respect – with all that that implies with regard to long-distance comfort, handling and safety – and offers an ideal combination of high performance and everyday practicality.





It's a C-Class, but not as you know it

It only takes one glance to appreciate the exceptional power of the C 63 AMG. The front view is dominated by the two pronounced powerdomes as well as the special AMG radiator grille with its central star and louvres. The front fog lamps at the outer edges of the front apron emphasise the width of the vehicle, as do the flared front wings. The side air vents in the front apron provide an outlet for the heat from the additional oil cooler. When equipped with the optional bi-xenon headlamps or the Intelligent Light System, the C 63 AMG features dark-tinted headlamp lenses.

The side view is dominated by the high-sheen 5-spoke 18-inch AMG light-alloy wheels or the optional multi-spoke 19-inch AMG light-alloy wheels, painted in titanium grey, as well as the attractively integrated "6.3 AMG" lettering on the wings and the AMG side skirts. At the back the tone is

set by characteristic brand design cues: the AMG rear apron with its black diffuser insert and three distinctive diffuser fins as well as the AMG sports exhaust system with two chromed twin tailpipes and standard-fit LED tail lights. The AMG spoiler lip on the boot lid reduces lift and provides greater directional stability and road adhesion.





An interior full of sporty highlights

Inside the C 63 AMG, exclusive AMG sports seats with integral head restraints and adaptive backrests are fitted as standard. Upholstery is available in ARTICO man-made leather/AMG fabric in black and alpaca grey. If optional fine nappa leather is ordered for the upholstery of these seats, the door centre panels and door armrests are also finished in nappa leather, the available colour combinations being black, alpaca grey or black/sahara beige. Exceptional sportiness is also the dominant theme throughout the rest of the interior. The cockpit features an AMG instrument cluster with the characteristic tubular design while the three-spoke nappa leather AMG performance steering wheel has a flattened lower segment and is equipped with authentic

motorsport-style shift paddles. AMG door sills, aluminium trim elements, the black roof liner and the brushed stainless-steel sports pedals complete this distinctly sporty interior.





Perfection just got better – the AMG Performance Studio

Only the specialists from the AMG Performance Studio in Affalterbach can hone the sportiness and dynamism of a C 63 AMG. The optional AMG Performance Package Plus offers components that are purpose-built for high performance: forged pistons, new connecting rods and modified crankshaft increase the output of the C 63 AMG by 22 kW to 358 kW. An improvement in output that is also reflected in the engine compartment with the variable intake manifold painted titanium grey.

Eye-catching brake callipers painted in red and the newly developed composite brake discs at the front also guarantee an exhilarating driving feel during deceleration. The AMG performance steering wheel trimmed in nappa leather/Alcantara® helps ensure you have always this sensation perfectly under control. Meanwhile, the exciting finale comes courtesy of the AMG Carbon spoiler lip at the rear.

As an option you can further individualise the C 63 AMG with the AMG rear axle locking differential, multi-spoke 19-inch AMG light-alloy wheels and AMG carbon-fibre trim. The upgraded appointments in designo black leather with fine black decorative stitching mean you can also relish the comfort of a luxury saloon in the sporty C 63 AMG.







My C-Class



The C-Class from its three most attractive sides

Standard equipment and the ELEGANCE
and AVANTGARDE design and equipment lines



The C-Class is packed with technology which automatically adjusts to the driver and his or her driving style. And its design and equipment lines are intended to reflect your personal style too – whether you prefer a classic, elegant or avant-garde look.



Standard equipment

One look at the exterior of the C-Class is enough to confirm that it has all the typical Mercedes-Benz characteristics: the chromed radiator grille is embellished with the laurel wreath badge, with the hallmark star standing above it on the bonnet. Fine chrome defines the top of the window areas, and three black louvres add emphasis to the front air intakes. The front fog lamps also feature black surrounds.



Chromed and black trim parts characterise the front of the C-Class

The colour concept continues all the way to the rear with the wide matt black handle.

The C-Class is also equipped with attractive light-alloy wheels in a 7-spoke design as standard.



Matt black is used for the boot lid handle



Standard equipment for the C-Class Estate

Featuring a chromed radiator grille embellished with the laurel wreath badge and the star standing on the bonnet, the standard-equipment version of the C-Class Estate has all the inimitable exterior characteristics of a genuine Mercedes-Benz. This version is made all the more attractive by the three black air-intake louvres and the front fog lamps which also have black surrounds. The black roof rails and the matt-black tailgate handle also complement the harmonious colour scheme. What's more, attractive light-alloy wheels come as standard.

The exterior design concept is taken up by the interior which has a classic black or alpaca grey finish. High-quality chrome details complement the fine trim parts with their piano-lacquer-effect finish (burr walnut is available as an alternative) to further enhance the stylish ambience. The seats are upholstered in Brighton fabric in black, alpaca

grey, black/beige or black/red while ARTICO man-made leather upholstery is available as an optional extra.



High-quality materials are used in the load compartment, too



Standard equipment – the interior

The interior, too, retains its classic feel, finished either in black or alpaca grey. Fine piano-lacquer-effect trim parts are supplemented with high-quality chrome details. The trim parts are also available in burr walnut as an option.



Numerous chrome details harmonise with the piano-lacquer-effect trim parts

Specially designed with horizontal seamlines, the seats are upholstered in black, alpaca grey, black/beige or black/red Brighton fabric, but can be finished in ARTICO man-made leather as an option.



Comfortable and elegant: the seats with their attractive fabric panels



The ELEGANCE design and equipment line

The first time you set eyes on your C-Class ELEGANCE is a very special moment. You will see the star standing on the bonnet, the optionally available LED daytime driving lights and elegant chrome elements on the bumpers, wings and doors. The polished aluminium beltline trim strip adds a par-



Numerous chrome trim parts lend the front its elegant character

ticularly stylish highlight to the sides of the C-Class. The rear of the C-Class ELEGANCE is distinctive with its chromed handle. 12-spoke light-alloy wheels provide a dazzling finishing touch.



Gleaming chrome is also used for the boot lid handle



The ELEGANCE design and equipment line for the C-Class Estate

Truly elegant design is always eye-catching – as in the case of the front section of the C-Class ELEGANCE, for example. The distinctive headlamps and the front fog lamps with their attractive chrome surrounds set the tone for the thoroughly elegant statement made by the chrome details on the bumpers, wings and doors and reinforced by the polished aluminium shoulderline trim strip and roof rails.

The tailgate of the C-Class ELEGANCE is equally striking with its chromed handle, while 12-spoke light-alloy wheels provide a dazzling finishing touch. Subtle colours characterise the interior. The Edinburgh fabric is available in black, alpaca grey or almond beige. ARTICO man-made leather or genuine leather upholstery can be ordered as optional extras. Burr walnut can be specified as an option instead of the standard fine-grain eucalyptus wood trim. Both harmonise beautifully with the stylish leather

steering wheel, which is standard in this design and equipment line.



The elegant design extends to the load compartment, too



The ELEGANCE design and equipment line – interior

Inside, the tone is set by a discreet combination of colours. The Edinburgh fabric is available in black, almond beige or alpaca grey. As an option, the comfortable seats can also be upholstered in ARTICO man-made leather or genuine



The natural beauty of the eucalyptus wood trim

leather. A leather steering wheel is fitted as standard. Upholstered in fabric or leather, the seats have decorative vertical stitching and the trim parts are in fine-grain eucalyptus. The interior can also be trimmed in burr walnut as an option.



The seats can be upholstered in leather – for example in alpaca grey – as an option



The AVANTGARDE design and equipment line

The AVANTGARDE design and equipment line turns the C-Class into an even more distinctive Mercedes. The agility of this model is conveyed instantly by the look of the front featuring a wide radiator grille with three bright silver louvres, distinctive chrome strips and the dominant star set in the centre. Chrome highlights – on the bumpers,



Striking and powerful: the face of the AVANTGARDE line

wings and doors, for example – emphasise the elegant profile of the C-Class and are complemented by the polished aluminium shoulderline trim strip and the chromed handle at the rear. Dark-tinted tail lights are another distinctive feature of the rear of the C-Class AVANTGARDE.



Embellishments at the rear include a chrome handle



The AVANTGARDE design and equipment line for the C-Class Estate

Avant-gardists always stand out – and the C-Class AVANTGARDE is no exception, its front instantly conveying the vehicle's agility through its wide radiator grille with three bright silver louvres, and the dominant star set in the centre. Chrome highlights on the bumpers, wings and doors emphasise the sleek lines of the C-Class. Particularly eye-catching touches include the polished aluminium shoulderline trim strip and roof rails as well as the chromed handle at the rear and the chrome band which runs round the whole vehicle.

Sportiness is the dominant theme inside the vehicle: the dashboard and floor are black while the door centre panels and door armrests are black or alpaca grey. Matt aluminium trim parts underline the sporty look. Wood trim in black bird's-eye maple are available as an option. The sporty theme continues with the standard Liverpool fabric/ARTICO man-made leather upholstery in black or alpaca grey.

Leather upholstery in black, alpaca grey, black/sahara beige or black/cognac brown is available as an optional extra.



The sporty look and feel is carried through to the load compartment



The AVANTGARDE design and equipment line – interior

Contrasting colours and materials lend the interior its sporty character. The floor and dashboard are black while the door centre panels and door armrests are black or alpaca grey. Finely textured aluminium trim parts emphasise the clean, sporty look. Wood trim in black bird's-eye maple is available as an option. The seats are distinguished by horizontal stitching and are

upholstered as standard in a Liverpool fabric/ARTICO man-made leather combination in black or alpaca grey. Optional appointments for the C-Class AVANTGARDE include two-tone leather upholstery with the black/sahara beige or black/cognac brown colour combination adding a particularly striking touch.



Aluminium trim for a refined, sporty look



The horizontal stitching adds to the dynamic ambience



	Standard equipment	ELEGANCE	AVANTGARDE
Exterior			
B-pillar trim	Matt black	High-gloss black	High-gloss black
Boot lid handle	Matt black	Chromed	Chromed
Boot lid handle	Matt black	Polished aluminium	Polished aluminium
Bumpers and side panels	Vehicle colour	Vehicle colour with chrome trim strips	Vehicle colour with chrome trim strips
Fog lamp surrounds	Black surround	Chrome surround	Chrome surround with two chrome bars
Line badge	Wings without line lettering	ELEGANCE line lettering on the wings	AVANTGARDE line lettering on the wings
Radiator grille	3 louvres, chromed, star on bonnet	3 louvres, chromed, star on bonnet	3 louvres, brilliant silver, central star on radiator grille
Tail lights (in conjunction with projection-beam headlamps)	Light meander	Light meander	Dark meander
Wheels	16-inch 7-spoke light-alloy wheels	17-inch 12-spoke light-alloy wheels for C 350 CDI BlueEFFICIENCY and C 350, 16-inch 12-spoke light-alloy wheels for all other models	17-inch 5-twin-spoke light-alloy wheels
Interior			
Gearshift console	Polyurethane shift lever gaiter, black plastic surround	Leather shift lever gaiter, chrome surround	Leather shift lever gaiter, chrome surround
Instrument cluster	Backplate in black	Tapered tube-style surrounds in anthracite	Tapered tube-style surrounds in silver
Seat design	Large panels with horizontal stitching	Thinly spaced vertical stitching	Sporty horizontal stitching
Steering wheel	Polyurethane-foam multifunction steering wheel	Luxury multifunction steering wheel in leather with 4.5-inch display in the instrument cluster	Luxury multifunction steering wheel in leather with 4.5-inch display in the instrument cluster
Trim parts	Piano-lacquer-effect finish	Eucalyptus wood	Aluminium
Upholstery	Brighton fabric	Edinburgh fabric	Liverpool fabric / ARTICO man-made leather



The AMG Sports package¹

If you would like to give your C-Class an even sportier character, the optional AMG Sports package offers an attractive combination of features: a dynamic AMG front apron, side skirts and a distinctive AMG rear apron as well as 17-inch 6-twin-spoke AMG light-alloy wheels with mixed-size tyres (225/45 at the front and 245/40 at the rear). You can also opt for 18-inch 5-twin-spoke AMG light-



Powerful: AMG rear apron and 17-inch AMG light-alloy wheels

¹Shown here in combination with the AVANTGARDE line

alloy wheels. The sports suspension, which is lowered by 15 mm, actively helps to enhance driving pleasure – as does the speed-sensitive sports steering. And while the perforated front brake discs and brake callipers with Mercedes-Benz lettering have a breathtakingly sporty look, they also deliver reassuring deceleration.



Powerful look, powerful effect: the perforated brake discs



Featuring large air intakes, the AMG front apron lends the C-Class an especially athletic look. The optionally available LED daytime driving lights will emphasise its sporty characteristics. The powerful AMG rear apron, meanwhile, along

with the side skirts and the high-shine 17-inch 6-twin-spoke AMG light-alloy wheels, gives the dynamic AMG Sports package an even keener edge.



Powerful: the AMG front apron



The AMG Sports package – interior

The AMG Sports package creates a special atmosphere inside the car too: the sports seats provide secure support and, like the rear seats, are upholstered in a Liverpool fabric/ARTICO man-made leather combination. Leather upholstery is available as an option.

Also included in the AMG Sports package is a sporty 3-spoke nappa leather steering wheel featuring shift paddles for



Behind the 3-spoke nappa leather steering wheel are shift paddles for manual gear changes (in conjunction with automatic transmission)

gear selection (when fitted in conjunction with an automatic transmission). The look of the instrument cluster is based on the tube-type design found in the C 63 AMG. Brushed stainless-steel sports pedals, black floor mats with AMG lettering, black roof liner and an aluminium-look shift/selector lever are further highlights of the sporty interior.



AMG through and through: the sports pedals in brushed stainless steel



Standard equipment (selection)

3-point seat belts and head restraints for all seats

6-speed manual transmission¹

Adaptive brake lights

ADAPTIVE BRAKE with ABS, ASR, brake drying function and Hill-Start Assist

AGILITY CONTROL suspension with selective damping system

Airbags (front), sidebags (front) and windowbags

ASSYST service interval indicator

Audio 20 CD

Belt tensioners with belt force limiters, front and outer rear seats

Brake Assist (BAS)

Central locking (remote control with selective and global opening)

Clear-lens front fog lamps

Clear-lens headlamps with projection-beam technology

Electronic Stability Program ESP®

Front armrest, with stowage compartment

Front seats with electrically adjustable height and backrest angle

Headlamp Assist

Heated exterior mirrors, electrically adjustable, with aspherically curved glass and clear-lens indicators

Heated rear window with time relay

Kneebag for driver

Multifunction steering wheel with trip computer

Outside temperature display

Power windows (4), with one-touch control

Remote boot lid release, operable via the key

Seat occupancy sensor for front passenger seat

THERMATIC 2-zone automatic climate control

¹ 7G-TRONIC automatic transmission fitted as standard in C 350 CDI BlueEFFICIENCY, C 350, C 350 CGI BlueEFFICIENCY, C 63 AMG and 4MATIC models



Control panel for THERMATIC 2-zone automatic climate control



Designer key

Ever thought of investing in precious metals?

The light-alloy wheels for the C-Class

The C-Class is equipped with 16-inch 7-spoke light-alloy wheels as standard. The ELEGANCE line features 16 or 17-inch light-alloy wheels

as standard, depending on the model; both have a 12-spoke design. The AVANTGARDE line is supplied with particularly sporty 17-inch 5-twin-

spoke wheels. Other attractive 16 to 18-inch light-alloy wheels are available as an option.



16-inch 7-spoke light-alloy wheel (standard)



16-inch 12-spoke light-alloy wheel (ELEGANCE)



17-inch 5-twin-spoke light-alloy wheel (AVANTGARDE)



16-inch 7-spoke light-alloy wheel



16-inch 7-spoke light-alloy wheel



17-inch 5-spoke light-alloy wheel



17-inch 7-twin-spoke light-alloy wheel



17-inch multi-spoke light-alloy wheel



5-twin-spoke 18-inch incenio light-alloy wheel "Pulaha"
(accessory wheel ex factory)

Rounding off the sporty look

AMG light-alloy wheels

Highly exclusive and sensationally sporty – high-sheen 17-inch 6-twin-spoke AMG light-alloy wheels shod with 225/45 tyres at the front and 245/40 tyres at the rear are available in conjunction with the AMG Sports package.

High-sheen 18-inch 5-twin-spoke AMG light-alloy wheels with size 225/40 tyres at the front and size 255/35 tyres at the rear are available as an optional extra for all models and in conjunction with the AMG Sports package.



17-inch 6-twin-spoke AMG light-alloy wheel



18-inch 5-twin-spoke AMG light-alloy wheel

If designer footwear is your thing ...

The incenio light-alloy wheels

The range of Mercedes-Benz accessories for the C-Class features exclusive incenio light-alloy wheels, such as the 17-inch 5-Y-spoke “Naantali” light-alloy wheel.



17-inch 5-Y-spoke “Naantali” light-alloy wheel

Even traffic bulletins can be a joy to listen to

The radios, navigation systems and surround sound system

The C-Class provides plenty of listening enjoyment when you're on the move. You can choose between three high-end audio systems, all of which are available as an option.

The Audio 20 CD features a 5-inch colour display, a CD player which can also play MP3 files, and Bluetooth® functionality. It can also be combined with a 6-CD changer as an option. The Audio 50 APS unit also includes a DVD drive for both audio functions and the integrated DVD navigation system with dynamic route guidance.

The highlight of the on-board entertainment range for the C-Class is COMAND APS. You can find out more about it on page 37.

All audio systems (except Audio 20 without a CD changer) can be combined with the Harman Kardon® Logic 7® surround sound system as an option. A DSP amplifier with Logic 7® technology and a total output of 450 W as well as 12 high-performance loudspeakers ensure great sound quality and a breathtaking surround sound experience, whether you are listening to a stereo or Dolby Digital 5.1 recording (Audio 20 CD offers stereo reproduction only).



Audio 20 with a CD drive



Audio 50 APS radio with a DVD navigation system

Optional extras (selection)	C 200 CDI BlueEFFICIENCY	C 220 CDI BlueEFFICIENCY	C 250 CDI BlueEFFICIENCY	C 250 CDI 4MATIC BlueEFFICIENCY	C 350 CDI BlueEFFICIENCY	C 350 CDI 4MATIC BlueEFFICIENCY	C 180 KOMPR. BlueEFFICIENCY	C 180 CGI BlueEFFICIENCY	C 200 KOMPR.	C 200 CGI BlueEFFICIENCY	C 250 CGI BlueEFFICIENCY	C 300	C 300 4MATIC	C 350	C 350 4MATIC	C 350 CGI BlueEFFICIENCY	C 63 AMG
5-speed automatic transmission	●	●	●	-	-	-	-	□	-	□	□	-	-	-	-	-	-
7G-TRONIC automatic transmission	-	-	-	□	□	□	-	-	-	-	-	●	□	□	□	□	□
AMG Sports package	●	●	●	●	●	●	●	●	●	●	●	●	●	●	●	●	-
Anti-theft alarm system with tow-away protection and infrared interior monitoring	●	●	●	●	●	●	●	●	●	●	●	●	●	●	●	●	●
Bi-xenon headlamps	●	●	●	●	●	●	●	●	●	●	●	●	●	●	●	●	●
COMAND APS multimedia system with a DVD drive	●	●	●	●	●	●	●	●	●	●	●	●	●	●	●	●	●
Cruise control	●	●	●	□	□	□	●	□	●	□	□	●	□	□	□	□	□
Dynamic handling package	-	●	●	●	●	-	-	-	●	●	●	●	-	●	-	●	-
Folding trailer coupling incl. ESP® trailer stabilisation	●	●	●	●	●	●	●	●	●	●	●	●	●	●	●	●	-

● Optional extra □ Standard - Not available ¹ Standard for C-Class Estate



The PARKTRONIC parking aid with visual proximity warning



Rear windscreen roller blind, electric (saloon only)

Optional extras (selection)	C 200 CDI BlueEFFICIENCY	C 220 CDI BlueEFFICIENCY	C 250 CDI BlueEFFICIENCY	C 250 CDI 4MATIC BlueEFFICIENCY	C 350 CDI BlueEFFICIENCY	C 350 CDI 4MATIC BlueEFFICIENCY	C 180 KOMPR. BlueEFFICIENCY	C 180 CGI BlueEFFICIENCY	C 200 KOMPR.	C 200 CGI BlueEFFICIENCY	C 250 CGI BlueEFFICIENCY	C 300	C 300 4MATIC	C 350	C 350 4MATIC	C 350 CGI BlueEFFICIENCY	C 63 AMG
Harman Kardon® Logic 7® surround sound system, Dolby Digital 5.1 and stereo, 12 loudspeakers, 450 W	●	●	●	●	●	●	●	●	●	●	●	●	●	●	●	●	●
Heated front seats	●	●	●	●	●	●	●	●	●	●	●	●	●	●	●	●	●
Intelligent Light System with bi-xenon headlamps and LED daytime driving lights	●	●	●	●	●	●	●	●	●	●	●	●	●	●	●	●	●
Interior and driver's-side exterior mirror automatically dimming, exterior mirrors electrically folding	●	●	●	●	●	●	●	●	●	●	●	●	●	●	●	●	●
KEYLESS-GO	●	●	●	●	●	●	-	●	-	●	●	●	●	●	●	●	●
Media interface	●	●	●	●	●	●	●	●	●	●	●	●	●	●	●	●	●
Memory package	●	●	●	●	●	●	●	●	●	●	●	●	●	●	●	●	●
Multicontour front seats	●	●	●	●	●	●	●	●	●	●	●	●	●	●	●	●	-

● Optional extra □ Standard - Not available



Intelligent Light System with bi-xenon headlamps



KEYLESS-GO - open the doors and start the engine without even taking the key out of your pocket

Optional extras (selection)	C 200 CDI BlueEFFICIENCY	C 220 CDI BlueEFFICIENCY	C 250 CDI BlueEFFICIENCY	C 250 CDI 4MATIC BlueEFFICIENCY	C 350 CDI BlueEFFICIENCY	C 350 CDI 4MATIC BlueEFFICIENCY	C 180 KOMPR. BlueEFFICIENCY	C 180 CGI BlueEFFICIENCY	C 200 KOMPR.	C 200 CGI BlueEFFICIENCY	C 250 CGI BlueEFFICIENCY	C 300	C 300 4MATIC	C 350	C 350 4MATIC	C 350 CGI BlueEFFICIENCY	C 63 AMG
Panoramic sliding sunroof with electric roller blinds	●	●	●	●	●	●	●	●	●	●	●	●	●	●	●	●	-
PARKTRONIC	●	●	●	●	●	●	●	●	●	●	●	●	●	●	●	●	●
PRE-SAFE® system	●	●	●	●	●	●	●	●	●	●	●	●	●	●	●	●	●
Rear windscreen roller blind, electric	●	●	●	●	●	●	●	●	●	●	●	●	●	●	●	●	●
Reversing camera	●	●	●	●	●	●	●	●	●	●	●	●	●	●	●	●	●
Sidebags in rear	●	●	●	●	●	●	●	●	●	●	●	●	●	●	●	●	●
Sliding sunroof	●	●	●	●	●	●	●	●	●	●	●	●	●	●	●	●	¹
Speed-sensitive power steering	●	●	●	●	●	●	●	●	●	●	●	●	●	●	●	□	-
THERMOTRONIC 3-zone luxury automatic climate control	●	●	●	●	●	●	●	●	●	●	●	●	●	●	●	●	●
Through-loading facility, folding rear seats	●	●	●	●	●	●	●	●	●	●	●	●	●	●	●	●	□

● Optional extra □ Standard - Not available ¹ Standard for C 63 AMG Estate



Rear control panel for THERMOTRONIC luxury 3-zone automatic climate control



Rear armrest with cup holders

Standard equipment (selection)

1/3 : 2/3 split-folding rear seat backrest with three 3-point seat belts and third head restraint

6-speed manual transmission¹

Adaptive brake lights

ADAPTIVE BRAKE with ABS, ASR, brake drying function and Hill-Start Assist

AGILITY CONTROL steering

AGILITY CONTROL suspension with selective damping system

Airbags (front), sidebags (front) and windowbags

ASSYST service interval indicator

Audio 20 CD

Belt tensioners with belt force limiters, front and outer rear seats

Brake Assist (BAS)

Clear-lens headlamps with projection-beam technology

Electronic Stability Program ESP®

Four load-securing rings

Front and rear armrests with stowage facility

Front seats with electrically adjustable height and backrest angle

Headlamp Assist

Kneebag for driver

Load compartment cover with one-touch control including retaining net (removable)

Loading sill with stainless steel cover

Multifunction steering wheel with trip computer

Outside temperature display

Power windows (4), with one-touch control

Roof rails in black

Side luggage nets

THERMATIC 2-zone automatic climate control

¹ 7G-TRONIC automatic transmission fitted as standard in C 350 CDI BlueEFFICIENCY, C 350, C 63 AMG and 4MATIC models



Integrated child seat (optional extra)



Sunblinds on rear doors (optional extra)

Optional extras (selection)	C 200 CDI BlueEFFICIENCY	C 220 CDI BlueEFFICIENCY	C 250 CDI BlueEFFICIENCY	C 250 CDI 4MATIC BlueEFFICIENCY	C 350 CDI BlueEFFICIENCY	C 350 CDI 4MATIC BlueEFFICIENCY	C 180 KOMPR. BlueEFFICIENCY	C 180 CGI BlueEFFICIENCY	C 200 KOMPR.	C 200 CGI BlueEFFICIENCY	C 250 CGI BlueEFFICIENCY	C 300	C 350	C 63 AMG
AMG Sports package	●	●	●	●	●	●	●	●	●	●	●	●	●	-
COMAND APS multimedia system with a DVD drive	●	●	●	●	●	●	●	●	●	●	●	●	●	●
Dark-tinted side and rear windows	●	●	●	●	●	●	●	●	●	●	●	●	●	●
Dynamic handling package	-	●	●	●	●	-	-	-	●	●	●	●	●	-
EASY-PACK load-securing kit	●	●	●	●	●	●	●	●	●	●	●	●	●	●
EASY-PACK tailgate	●	●	●	●	●	●	●	●	●	●	●	●	●	●
Panoramic sliding sunroof with electric roller blinds	●	●	●	●	●	●	●	●	●	●	●	●	●	-
PRE-SAFE® system	●	●	●	●	●	●	●	●	●	●	●	●	●	●
Self-levelling suspension	●	●	●	●	●	●	●	●	●	●	●	●	●	-
Sunblinds on rear doors	●	●	●	●	●	●	●	●	●	●	●	●	●	●
Tilt-down trailer coupling	●	●	●	●	●	●	●	●	●	●	●	●	●	-

● Optional extra □ Standard - Not available



Panoramic sliding sunroof (optional extra)



EASY-PACK tailgate (optional extra)



As personal as your own handwriting

Individualise your vehicle in line
with your own tastes with the designo range

How can you personalise a Mercedes C-Class so that it truly becomes your Mercedes? The answer is designo, a range of carefully selected materials which allows you to turn your vehicle into a unique masterpiece. With superb leather appointments, perfectly colour-coordinated fabric roof lining and matching velour floor mats. As well as having instant appeal, the remarkable quality which characterises the look and feel of even the smallest details of the designo range of appointments is a source of lasting pleasure.

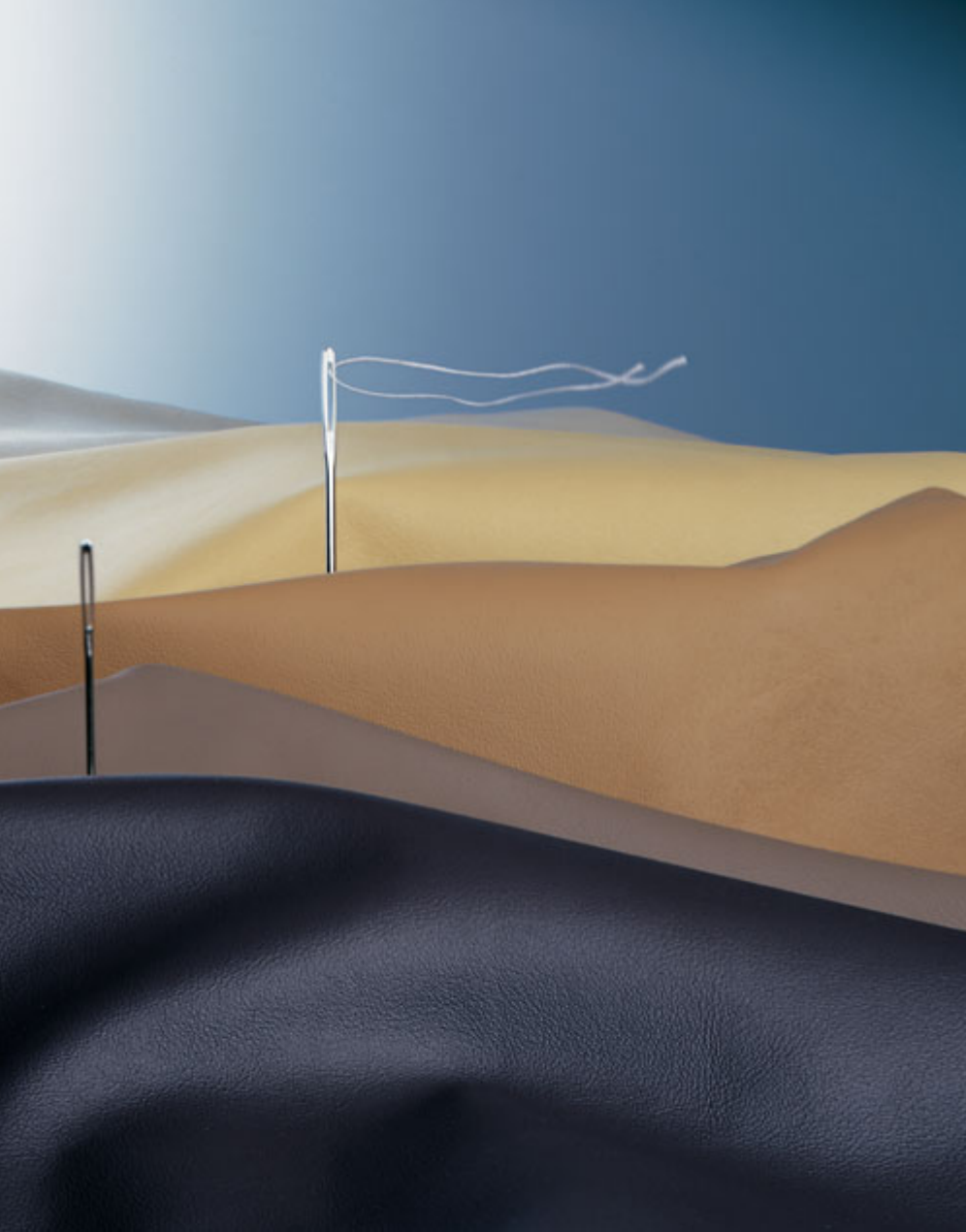

As unique as you are

The designo leather appointments

designo is synonymous with outstanding craftsmanship. Like that of the experienced upholsterers, for example, who painstakingly turn hand-picked hides into beautiful leather appointments. Two of these sets of exclusive designo leather appointments are available for the C-Class Saloon and Estate.

You can choose between the leather colours designo porcelain and designo sand. The designo seating has a characteristic two-tone design with the seat centre panels in the chosen designo colour and the side bolsters in black.



Two-tone: designo leather appointments for the Mercedes C-Class

In addition, high-quality designo metal badges are set into the backrests of the front seats. The interior appointments are completed by the black fabric roof lining and velour floor mats with a designo leather surround in black.

The designo leather appointments are available only in conjunction with the ELEGANCE and AVANTGARDE lines and cannot be specified for the C 63 AMG.



The hallmark of quality and meticulous workmanship: the designo badge





Those special extras

Genuine Mercedes-Benz accessories for the C-Class Saloon

From attractive to practical – there's a whole selection of extras to choose from in the Mercedes-Benz accessories range.

Take the genuine styling products, for example. The line-up for the C-Class includes front apron spoiler lips, a rear apron, illuminated door sill panels in brushed stainless steel, rear/roof spoilers or incenio light-alloy wheels.



A dazzling addition: the illuminated stainless steel door sill panel

The range of accessories has plenty of other extras in store, too, including carrier systems, wood/leather steering wheels and cup holders. For details of the full range, please see our special C-Class accessories brochure, or contact your Mercedes-Benz dealer who will be happy to help you.



One less reason to break your journey: the cup holder for the centre console



Perfect, right down to the smallest detail

Practical and versatile: genuine accessories for the C-Class Estate

Practicality and attractiveness are defining characteristics of the C-Class Estate. So it's good to know that there is a range of genuine accessories which allow you to enhance it to meet your specific requirements without compromising these key attributes. Suppose you like skiing, for example. A Mercedes-Benz roof box might be just what you need. As well as offering good aerodynamics and very attractive styling, it's also extremely practical and versatile. If cycling's your

thing, by contrast, how about the New Alustyle bicycle rack?

You'll find loading your C-Class is also particularly easy and convenient with our load compartment products. What's more, they ensure the high standards of travelling safety which are synonymous with Mercedes-Benz. The shallow load compartment tub, for example, not only allows items to be carried hygienically but also

fits the load compartment perfectly, has a non-slip surface and is food-safe.

The concertina-type folding bag comprises two bags made from tough, washable nylon fabric. Each bag has two large compartments and two handles which make it easy to remove and carry.

For details, please see the C-Class accessories brochure or contact your Mercedes-Benz dealer.



Basic carrier bars with New Alustyle bicycle rack



Concertina-type folding bag



Boot tub, shallow



Irresistibly attractive. And extremely resistant

The extra-scratch-resistant clearcoat of the C-Class

Stars are meant to shine, and if ours seem to shine brighter, it's because we have followed the Mercedes tradition of pioneering new technologies and have developed one of the best clearcoats available in the automotive market. Thanks to this innovative Mercedes-Benz paint system, our vehicles now make an even more impressive visual statement which is also reflected in their even higher value retention. This clearcoat developed by Mercedes-Benz is more resistant than conventional clearcoats by virtue of its particularly dense molecular structure. It also produces

a more lasting and noticeably more intense sheen. Whether you choose a metallic or non-metallic paint finish, this more scratch-resistant clearcoat is less sensitive to weathering and environmental influences, rain and snow, sunlight and temperature fluctuations. It is also more resistant to chemical attack and physical wear and tear, such as that caused by automatic car washes. You can rest assured that your new Mercedes will continue to shine elegantly throughout its long life.

The C-Class paintwork puts the finishing touch to the carefully crafted Mercedes-Benz corrosion protection system, which includes zinc phosphating and electrophoretic dip priming stages for long-lasting protection. Furthermore, Mercedes-Benz makes extensive use of eco-friendly water-based paints.

NON-METALLIC PAINTS



040 black



590 fire opal



650 calcite white

METALLIC PAINTS



197 obsidian black



230 indigolite blue



300 periclase green



359 tanzanite blue

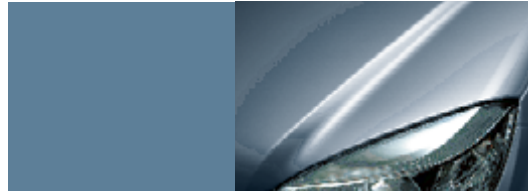

792 palladium silver

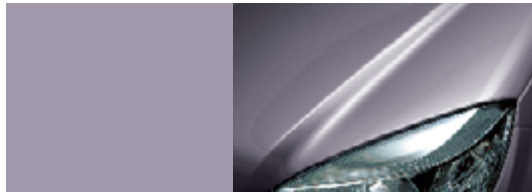

755 tenorite grey

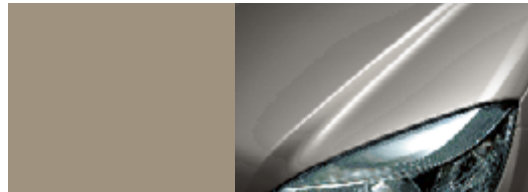

794 pearl beige



775 iridium silver



798 sanidine beige

The seats of a Mercedes-Benz offer an extremely high degree of comfort thanks to the special way in which the seat cushions are sprung and the use of separate foam elements for the centre panel of the seat cushion and the sides. The combination of the seat cushion spring set-up, which is precisely tuned to the vehicle, and the selection of the appropriate degree of cushion density results in exceptional springing and damping characteristics. You can create an ideal seating environment which reflects your own preferences by choosing from our range of fabric and/or leather upholstery. The fabric patterns have been developed to complement and harmonise with the different design and equipment lines of the C-Class.

Standard

Brighton fabric

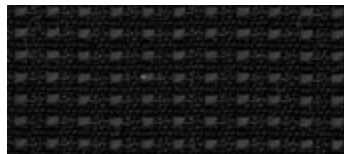

001 black



018 alpaca grey

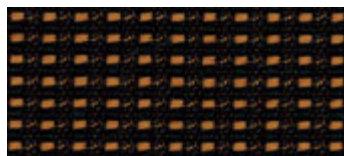

055 black/beige



057 black/red

ELEGANCE

Edinburgh fabric

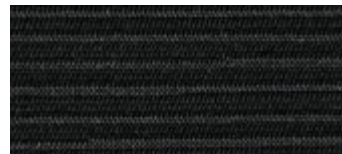

401 black



415 almond beige



418 alpaca grey

AVANTGARDE and AMG Sports package

Liverpool fabric/
ARTICO man-made leather

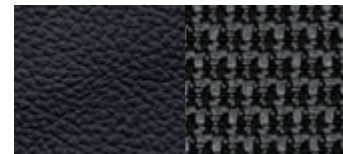

701 black



718 alpaca grey

Standard and ELEGANCE

ARTICO man-made leather

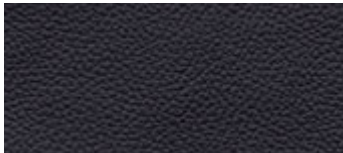

101 black

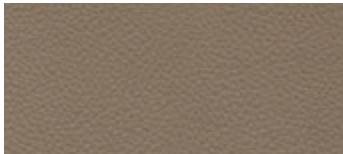

115 almond beige
(for ELEGANCE only)



118 alpaca grey

ELEGANCE, AVANTGARDE and AMG Sports package¹

Leather

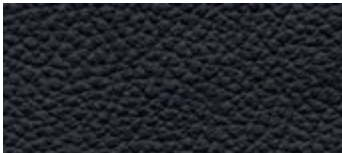

201 black

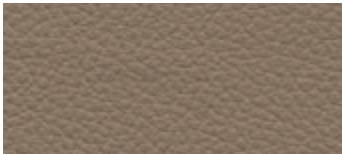

215 almond beige
(for ELEGANCE only)

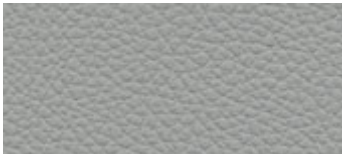

218 alpaca grey

AVANTGARDE and AMG Sports package¹

Leather



205 black/sahara beige

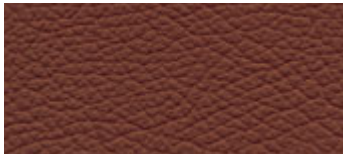

207 black/cognac brown

designo

Leather²



X77 sand



X87 porcelain

¹Leather appointments only in conjunction with ELEGANCE and AVANTGARDE

²Only in conjunction with the ELEGANCE or AVANTGARDE design and equipment lines. designo leather appointments are not available for the C 63 AMG

Many hours of care and attention are lavished on every Mercedes-Benz. The wood trim is just one example of the craftsmanship involved: it takes around three weeks to turn this natural product into a perfectly finished Mercedes component.

Special computer-controlled planing machines slice the thinnest of veneers from the wood. The ones whose colour and grain characteristics match best are then used to create a complete veneer. This process involves placing the individual layers on thin substrate elements with intermediate layers of aluminium and glue sheets to ensure strength and durability. Up to 100 of these layers are applied by hand to create a trim strip. Take a close look at your C-Class and you will see how much care has gone into every detail.

Standard

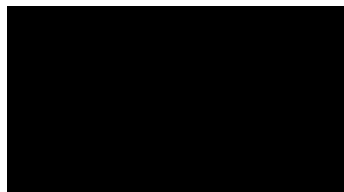

Piano-lacquer-effect finish



Burr walnut (optional extra)

ELEGANCE

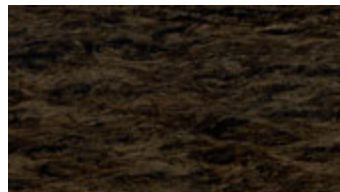

Eucalyptus



Burr walnut (optional extra)

AVANTGARDE



Aluminium



Black bird's-eye maple (optional extra)

	NON-METALLIC PAINTS			METALLIC PAINTS									
	black	fire opal	calcite white	obsidian black	indigolite blue	periclase green	tanzanite blue	tenorite grey	iridium silver	palladium silver	pearl beige	sandine beige	
Brighton fabric (standard)													
black	●	●	●	●	●	●	●	●	●	●	●	●	
alpaca grey	●	○	●	●	●	○	●	●	●	○	△	△	
black / beige	●	△	△	●	△	△	△	△	△	△	●	●	
black / red	●	○	●	●	○	△	○	●	●	△	△	△	
Edinburgh fabric (ELEGANCE)													
black	●	●	●	●	●	●	●	●	●	●	●	●	
almond beige	●	○	○	●	○	●	○	●	△	△	●	●	
alpaca grey	●	○	●	●	●	○	●	●	●	○	△	△	
Liverpool fabric / ARTICO man-made leather (AVANTGARDE and AMG Sports package)													
black	●	●	●	●	●	●	●	●	●	●	●	●	
alpaca grey	●	○	●	●	●	○	●	●	●	○	△	△	
ARTICO man-made leather (standard and ELEGANCE)													
black	●	●	●	●	●	●	●	●	●	●	●	●	
almond beige	●	○	○	●	○	●	○	△	△	△	●	●	
alpaca grey	●	○	●	●	●	○	●	●	●	○	△	△	
Leather (ELEGANCE, AVANTGARDE and AMG Sports package)													
black	●	●	●	●	●	●	●	●	●	●	●	●	
almond beige	●	○	○	●	○	●	○	△	△	△	●	●	
alpaca grey	●	○	●	●	●	○	●	●	●	○	△	△	
Leather (AVANTGARDE)													
black / sahara beige	●	○	○	●	●	○	●	○	△	△	●	●	
black / cognac brown	●	△	●	●	○	△	○	△	●	○	○	○	

● Recommended ○ Possible △ Not recommended

	C 200 CDI BlueEFFICIENCY	C 220 CDI BlueEFFICIENCY	C 250 CDI BlueEFFICIENCY	C 250 CDI 4MATIC BlueEFFICIENCY ⁵	C 350 CDI BlueEFFICIENCY
No. of cylinders/arrangement	4 / in-line	4 / in-line	4 / in-line	4 / in-line	6 / V
Total displacement (cc)	2143	2143	2143	2143	2987
Rated output ¹ (kW at rpm)	100/2800	125/3000-4200	150/4200	150/4200	170/3800
Rated torque ¹ (Nm at rpm)	360/1600-2600	400/1400-2800	500/1600-1800	500/1600-1800	540/1600-2400
Compression ratio	17.5	16.2	16.2	16.2	17.7
Acceleration from 0 to 100 km/h (s) (automatic transmission)	9.2 (9.7)	8.4 (7.7)	7.0 (7.0)	- (7.0)	- (6.4)
Top speed, approx. (km/h) (automatic transmission)	218 (214)	232 (231)	240 (240)	- (240)	- (250 ²)
Tyre size					
front	195/60 R 16	205/55 R 16	205/55 R 16	205/55 R 16	225/45 R 17
rear	195/60 R 16	205/55 R 16	205/55 R 16	205/55 R 16	225/45 R 17
Fuel	Diesel	Diesel	Diesel	Diesel	Diesel
Fuel consumption ³ (l/ 100 km)					
urban (automatic transmission)	6.5-7.1 (7.4-8.1)	6.2-6.7 (8.1-8.5)	6.6-7.1 (8.1-8.5)	- (8.7-9.0)	- (8.6-8.9)
extra-urban (automatic transmission)	4.1-4.8 (4.4-5.2)	4.0-4.6 (4.4-5.1)	4.2-4.8 (4.4-5.1)	- (5.0-5.4)	- (5.4-5.7)
combined (automatic transmission)	5.0-5.7 (5.5-6.3)	4.8-5.4 (5.8-6.4)	5.1-5.6 (5.8-6.4)	- (6.4-6.8)	- (6.6-6.9)
CO ₂ emissions ³ (g/km), combined (automatic transmission)	130-148 (144-164)	127-143 (153-167)	134-147 (153-167)	- (167-177)	- (174-180)
Tank capacity (l)/incl. approx. reserve	59/8	59/8	59/8	59/8	66/8
Boot capacity (l)	475	475	475	475	475
Turning circle diameter (m)	10.84	10.84	10.84	10.84	10.84
Kerb weight ⁴ (kg) (automatic transmission)	1575 (1590)	1610 (1610)	1615 (1615)	- (1675)	- (1700)
Permissible gross vehicle weight (kg) (automatic transmission)	2080 (2095)	2115 (2115)	2120 (2120)	- (2180)	- (2205)

¹ Figures according to Directive 80/1269/EEC in the currently applicable version ² Electronically governed ³ The figures shown were obtained in accordance with the prescribed measuring process (Directive 80/1268/EEC in the currently applicable version). The figures are not based on an individual vehicle and do not constitute part of the product offer; they are provided solely for the purposes of comparison between different vehicle models

C 350 CDI 4MATIC BlueEFFICIENCY	C 180 KOMPRESSOR BlueEFFICIENCY	C 180 CGI BlueEFFICIENCY	C 200 KOMPRESSOR	C 200 CGI BlueEFFICIENCY	C 250 CGI BlueEFFICIENCY	C 300
6/V	4/in-line	4/in-line	4/in-line	4/in-line	4/in-line	6/V
2987	1597	1796	1796	1796	1796	2996
170/3800	115/5200	115/5000	135/5500	135/5250	150/5500	170/6000
540/1600-2400	230/2800-4600	250/1600-4200	250/2800-5000	270/1800-4600	310/2000-4300	300/2500-5000
17.7	9.3	9.3	8.5	9.3	9.3	11.3
- (6.4)	9.5 (9.9)	- (9.0)	8.6 (-)	- (8.2)	- (7.4)	7.3 (7.2)
- (250 ²)	230 (223)	- (220)	235 (-)	- (232)	- (240)	250 ² (246)
225/45 R 17	195/60 R 16	195/60 R 16	205/55 R 16	205/55 R 16	205/55 R 16	205/55 R 16
225/45 R 17	195/60 R 16	195/60 R 16	205/55 R 16	205/55 R 16	205/55 R 16	205/55 R 16
Diesel	Premium petrol	Premium petrol	Premium petrol	Premium petrol	Premium petrol	Premium petrol
- (9.1-9.2)	9.5-9.9 (10.1-10.5)	- (10.1-10.6)	10.5-10.7 (-)	- (10.1-10.7)	- (10.1-10.7)	13.7-13.9 (13.6-13.8)
- (5.9-6.1)	5.1-5.7 (5.4-6.0)	- (5.5-6.2)	5.8-6.0 (-)	- (5.5-6.2)	- (5.5-6.2)	6.9-7.1 (7.0-7.2)
- (7.0-7.2)	6.7-7.3 (7.1-7.7)	- (7.1-7.8)	7.6-7.8 (-)	- (7.2-7.9)	- (7.2-7.9)	9.4-9.6 (9.4-9.6)
- (185-189)	159-173 (169-183)	- (166-181)	180-185 (-)	- (168-184)	- (168-184)	220-225 (219-224)
66/8	66/8	59/8	66/8	59/8	59/8	66/8
475	475	475	475	475	475	475
10.84	10.84	10.84	10.84	10.84	10.84	10.84
- (1760)	1485 (1500)	- (1495)	1490 (-)	- (1505)	- (1505)	1555 (1575)
- (2265)	1970 (1985)	- (2000)	1975 (-)	- (2010)	- (2010)	2040 (2060)

⁴ Figures according to Directive 92/21/EC, version 95/48/EC (kerb weight with fuel tank 90% full, driver, 68 kg, and luggage, 7 kg) for standard-specification vehicles. Optional extras and accessories will generally increase this figure and reduce the payload capacity accordingly

⁵ Expected to be available from the end of 1st quarter 2010

	C 300 4MATIC	C 350	C 350 4MATIC	C 350 CGI BlueEFFICIENCY	C 63 AMG
No. of cylinders/arrangement	6/V	6/V	6/V	6/V	8/V
Total displacement (cc)	2996	3498	3498	3498	6208
Rated output ¹ (kW at rpm)	170/6000	200/6000	200/6000	215/6400	336/6800
Rated torque ¹ (Nm at rpm)	300/2500-5000	350/2400-5000	350/2400-5000	365/3000-5100	600/5000
Compression ratio	11.3	10.7	10.7	12.2	11.3
Acceleration from 0 to 100 km/h (s) (automatic transmission)	- (7.3)	- (6.4)	- (6.3)	- (6.2)	- (4.5/4.4 ⁵)
Top speed, approx. (km/h) (automatic transmission)	- (243)	- (250 ²)	- (250 ²)	- (250 ²)	- (250 ²)
Tyre size					
front	205/55 R 16	225/45 R 17	225/45 R 17	225/45 R 17	235/40 R 18
rear	205/55 R 16	225/45 R 17	225/45 R 17	225/45 R 17	255/35 R 18
Fuel	Premium petrol	Premium petrol	Premium petrol	Premium petrol	Super Plus
Fuel consumption ³ (l/ 100 km)					
urban (automatic transmission)	- (13.7-13.9)	- (14.2-14.5)	- (14.8)	- (12.0-12.6)	- (20.9)
extra-urban (automatic transmission)	- (7.3-7.5)	- (7.4-7.8)	- (7.7)	- (6.1-6.7)	- (9.2)
combined (automatic transmission)	- (9.6-9.8)	- (9.9-10.2)	- (10.2)	- (8.3-8.9)	- (13.4)
CO ₂ emissions ³ (g/km), combined (automatic transmission)	- (224-229)	- (232-239)	- (239)	- (193-208)	- (319)
Tank capacity (l)/incl. approx. reserve	66/8	66/8	66/8	66/8	66/14
Boot capacity (l)	475	475	475	475	475
Turning circle diameter (m)	10.84	10.84	10.84	10.84	11.75
Kerb weight ⁴ (kg) (automatic transmission)	- (1635)	- (1610)	- (1670)	- (1615)	- (1730)
Permissible gross vehicle weight (kg) (automatic transmission)	- (2120)	- (2095)	- (2155)	- (2100)	- (2170)

¹ Figures according to Directive 80/1269/EEC in the currently applicable version ² Electronically governed ³ The figures shown were obtained in accordance with the prescribed measuring process (Directive 80/1268/EEC in the currently applicable version. The figures are not based on an individual vehicle and do not constitute part of the product offer; they are provided solely for the purposes of comparison between different vehicle models ⁴ Figures according to Directive 92/21/EC, version 95/48/EC (kerb weight with fuel tank 90% full, driver, 68 kg, and luggage, 7 kg) for standard-specification vehicles. Optional extras and accessories will generally increase this figure and reduce the payload capacity accordingly

⁵ In conjunction with AMG Performance Package Plus (optional)

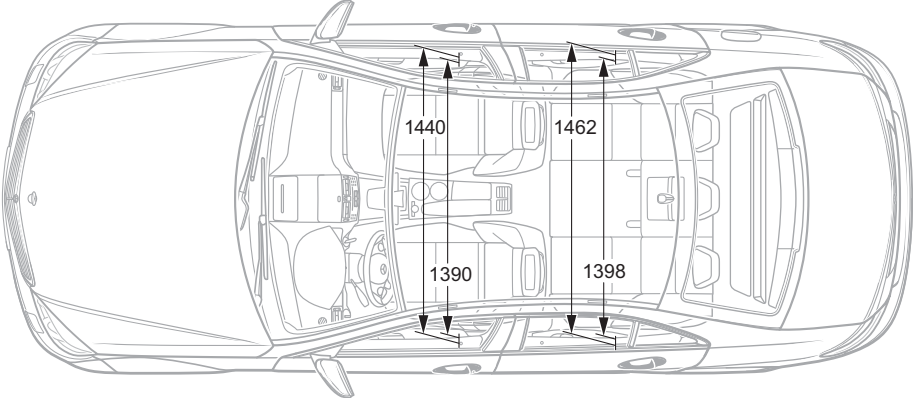
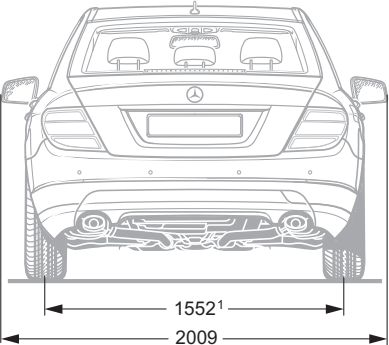
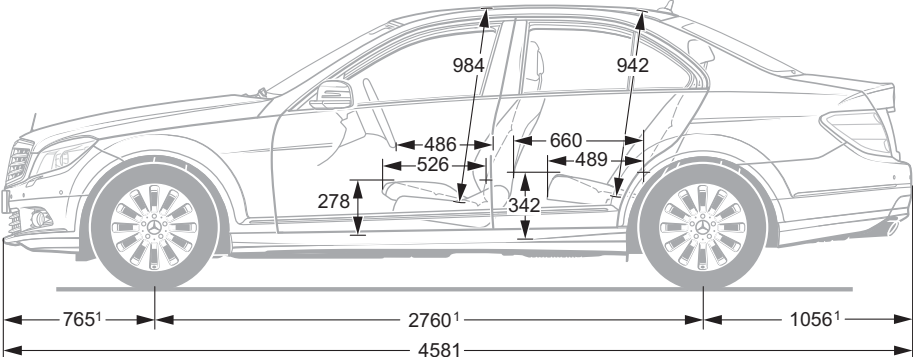
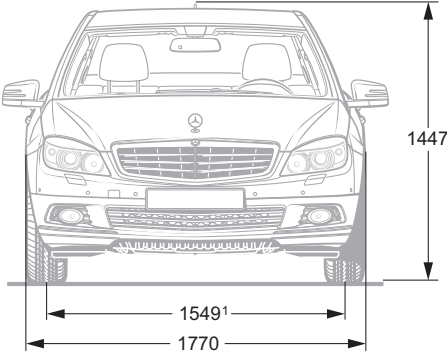

All measurements in millimetres. The dimensions shown are mean values and apply to standard-specification, unladen vehicles
 † Carrying 3 people, each weighing 68 kg

	C 200 CDI BlueEFFICIENCY	C 220 CDI BlueEFFICIENCY	C 250 CDI BlueEFFICIENCY	C 250 CDI 4MATIC BlueEFFICIENCY⁴
No. of cylinders/arrangement	4 /in-line	4 /in-line	4 /in-line	4 /in-line
Total displacement (cc)	2143	2143	2143	2143
Rated output¹ (kW at rpm)	100/2800	125/3000–4200	150/4200	150/4200
Rated torque¹ (Nm at rpm)	360/1600–2600	400/1400–2800	500/1600–1800	500/1600–1800
Compression ratio	17.5	16.2	16.2	16.2
Acceleration from 0 to 100 km/h (s) (automatic transmission)	9.6 (10.1)	8.8 (8.1)	7.8 (7.2)	– (7.2)
Top speed, approx. (km/h) (automatic transmission)	209 (207)	219 (219)	238 (237)	– (235)
Tyre size				
front	205/55 R 16	205/55 R 16	205/55 R 16	205/55 R 16
rear	205/55 R 16	205/55 R 16	205/55 R 16	205/55 R 16
Fuel	Diesel	Diesel	Diesel	Diesel
Fuel consumption² (l/ 100 km)				
urban (automatic transmission)	6.7–7.4 (7.7–8.1)	6.3–6.6 (8.2–8.8)	6.7–7.1 (8.3–8.8)	– (9.1–9.7)
extra-urban (automatic transmission)	4.4–5.1 (4.7–5.4)	4.1–4.7 (4.7–5.2)	4.5–5.1 (4.8–5.2)	– (5.2–5.8)
combined (automatic transmission)	5.2–5.9 (5.8–6.4)	4.9–5.4 (6.0–6.5)	5.3–5.8 (6.1–6.5)	– (6.6–7.3)
CO₂ emissions² (g/km), combined (automatic transmission)	137–155 (153–167)	130–144 (159–171)	140–153 (160–171)	– (173–190)
Tank capacity (l)/incl. approx. reserve	59/8	59/8	59/8	59/8
Boot capacity (l)	485–1500	485–1500	485–1500	485–1500
Turning circle diameter (m)	10.84	10.84	10.84	10.84
Kerb weight³ (kg) (automatic transmission)	1635 (1650)	1665 (1665)	1675 (1675)	– (1735)
Permissible gross vehicle weight (kg) (automatic transmission)	2175 (2190)	2205 (2205)	2215 (2215)	– (2275)

¹ Figures according to Directive 80/1269/EEC in the currently applicable version

² The figures shown were obtained in accordance with the prescribed measuring process (Directive 80/1268/EEC in the currently applicable version). The figures are not based on an individual vehicle and do not constitute part of the product offer; they are provided solely for the purposes of comparison between different vehicle models

C 350 CDI BlueEFFICIENCY	C 350 CDI 4MATIC BlueEFFICIENCY	C 180 KOMPRESSOR BlueEFFICIENCY	C 180 CGI BlueEFFICIENCY	C 200 KOMPRESSOR	C 200 CGI BlueEFFICIENCY
6/V	6/V	4/in-line	4/in-line	4/in-line	4/in-line
2987	2987	1597	1796	1796	1796
170/3800	170/3800	115/5200	115/5000	135/5500	135/5250
540/1600-2400	540/1600-2400	230/2800-4600	250/1600-4200	250/2800-5000	270/1800-4600
17.7	17.7	9.3	9.3	8.5	9.3
- (6.5)	- (6.5)	9.8 (-)	- (9.2)	8.8 (-)	- (8.4)
-	-	223	-	228	-
(244)	(242)	(-)	(213)	(-)	(225)
225/45 R 17	225/45 R 17	205/55 R 16	205/55 R 16	205/55 R 16	205/55 R 16
225/45 R 17	225/45 R 17	205/55 R 16	205/55 R 16	205/55 R 16	205/55 R 16
Diesel	Diesel	Premium petrol	Premium petrol	Premium petrol	Premium petrol
- (8.8-9.0)	- (9.2-9.3)	9.4-9.8 (-)	- (10.3-10.8)	10.7-10.9 (-)	- (10.3-10.7)
- (5.7-5.9)	- (6.0-6.4)	5.5-6.0 (-)	- (5.7-6.4)	6.0-6.2 (-)	- (5.9-6.5)
- (6.8-7.0)	- (7.2-7.4)	6.9-7.4 (-)	- (7.4-8.0)	7.8-8.0 (-)	- (7.5-8.0)
-	-	164-176	-	184-189	-
(180-184)	(191-195)	(-)	(172-186)	(-)	(175-188)
66/8	66/8	66/8	59/8	66/8	59/8
485-1500	485-1500	485-1500	485-1500	485-1500	485-1500
10.84	10.84	10.84	10.84	10.84	10.84
- (1750)	- (1810)	1530 (-)	- (1555)	1540 (-)	- (1565)
-	-	2060	-	2070	-
(2280)	(2340)	(-)	(2095)	(-)	(2105)

³ Figures according to Directive 92/21/EC, version 95/48/EC (kerb weight with fuel tank 90% full, driver, 68 kg, and luggage, 7 kg) for standard-specification vehicles. Optional extras and accessories will generally increase this figure and reduce the payload capacity accordingly

⁴ Expected to be available from the end of 1st quarter 2010

	C 250 CGI BlueEFFICIENCY	C 300	C 350	C 63 AMG
No. of cylinders/arrangement	4 /in-line	6/V	6/V	8/V
Total displacement (cc)	1796	2996	3498	6208
Rated output ¹ (kW at rpm)	150/5500	170/6000	200/6000	336/6800
Rated torque ¹ (Nm at rpm)	310/2000–4300	300/2500–5000	350/2400–5000	600/5000
Compression ratio	9.3	11.3	10.7	11.3
Acceleration from 0 to 100 km/h (s) (automatic transmission)	– (7.5)	7.5 (7.5)	– (6.5)	– (4.6/4.5 ⁵)
Top speed, approx. (km/h) (automatic transmission)	– (233)	242 (240)	– (250 ²)	– (250 ²)
Tyre size				
front	205/55 R 16	225/45 R 17	225/45 R 17	235/40 R 18
rear	205/55 R 16	225/45 R 17	225/45 R 17	255/35 R 18
Fuel	Premium petrol	Premium petrol	Premium petrol	Super Plus
Fuel consumption ³ (l/ 100 km)				
urban (automatic transmission)	– (10.3–10.7)	13.9–14.1 (13.7–13.9)	– (14.8–15.1)	– (21.1)
extra-urban (automatic transmission)	– (5.9–6.5)	7.1–7.3 (7.2–7.4)	– (7.4–7.8)	– (9.5)
combined (automatic transmission)	– (7.5–8.0)	9.6–9.8 (9.6–9.8)	– (10.1–10.4)	– (13.7)
CO ₂ emissions ³ (g/km), combined (automatic transmission)	– (175–188)	224–229 (224–229)	– (235–242)	– (326)
Tank capacity (l)/incl. approx. reserve	59/8	66/8	66/8	66/14
Boot capacity (l)	485–1500	485–1500	485–1500	485–1500
Turning circle diameter (m)	10.84	10.84	10.84	11.75
Kerb weight ⁴ (kg) (automatic transmission)	– (1575)	1600 (1615)	– (1655)	– (1795)
Permissible gross vehicle weight (kg) (automatic transmission)	– (2115)	2130 (2145)	– (2185)	– (2275)

¹ Figures according to Directive 80/1269/EEC in the currently applicable version² Electronically governed³ The figures shown were obtained in accordance with the prescribed measuring process (Directive 80/1268/EEC in the currently applicable version). The figures are not based on an individual vehicle and do not constitute part of the product offer; they are provided solely for the purposes of comparison between different vehicle models⁴ Figures according to Directive 92/21/EC,

version 95/48/EC (kerb weight with fuel tank 90 % full, driver, 68 kg, and luggage, 7 kg) for standard-specification vehicles. Optional extras and accessories will generally increase this figure and reduce the payload capacity accordingly

⁵ In conjunction with AMG Performance Package Plus (optional)

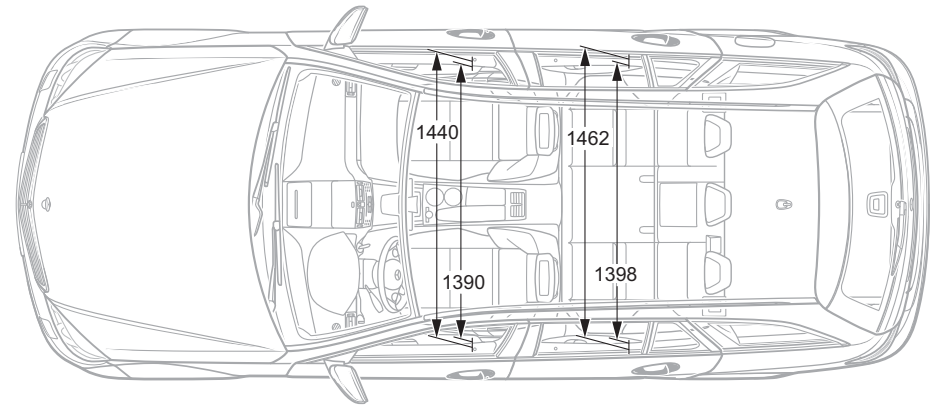
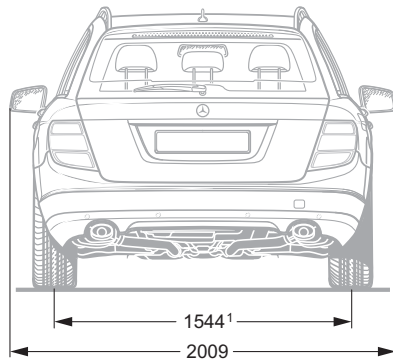
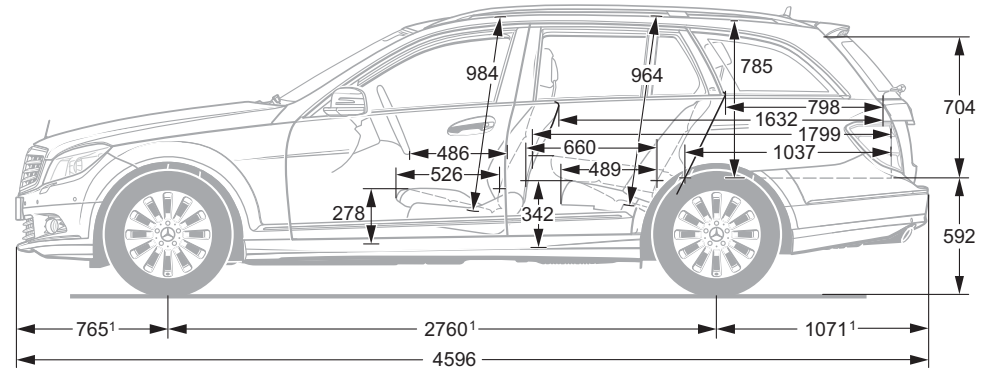
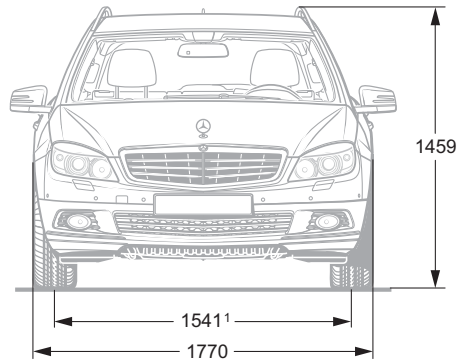

All measurements in millimetres. The dimensions shown are mean values and apply to standard-specification, unladen vehicles

¹Carrying 3 people, each weighing 68 kg

Anyone opting for a Mercedes buys far more than just a car

Comprehensive service offered by Mercedes-Benz

Mercedes-Benz for you. It all started in Berlin at the end of 2000: the concept of the car dealership was reinvented with the opening of the first Mercedes-Benz Centre. Featuring the entire Mercedes-Benz model line-up as well as the accessories range, brand merchandise and an attractive programme of events, the Centres offer a welcoming environment in which to experience the brand at first hand. But it's not just in major cities that you can experience the legendary Mercedes-Benz brand and service. A close-knit network of company-owned branches and authorised dealers ensures that you are never far from the wide range of services, the comprehensive customer care and the high quality which you expect from Mercedes-Benz. And you can count on their support at every stage – before you buy your Mercedes, during the purchase process and, most importantly, for a long time afterwards, too.

Mercedes-Benz Museum. More than 120 years of automotive history in one place – this is what awaits you at the Mercedes-Benz Museum in Stuttgart. Experience the unique excitement, and embark upon a thrilling journey through time. Housed inside an architecturally impressive building, over 1500 exhibits on nine levels give you an insight into the unique tradition and powers of innovation of the Mercedes-Benz brand. Plus you can see the world's first two automobiles in the shape of the Benz Patent-Motorwagen (motor car) and the Daimler motorised carriage – both from the year 1886. Two linked circuits take you from the beginnings of the automobile, past a series of unforgettable classics, through over 100 years of motor racing history and, finally, on to a glimpse of what the future holds – in an area covering a total of 16,500 square metres. Enjoy the unique brand experience. We look forward to your visit. Further information can be found at www.mercedes-benz.com/museum

MercedesCard. Your ticket to the Mercedes-Benz experience: four times a year we will send you exciting details of a selected range of events and services which we have put together exclusively for you. Then there is the Mercedes Magazine with its fascinating reports and articles. But the MercedesCard also has many other uses: as a VISA credit card, it is an internationally accepted means of payment. Answer the annual questionnaire and we'll even waive the card fee. Plus the card offers further benefits to provide you with peace of mind, such as the Mercedes-Benz insurance package at no extra charge and the exclusively compiled MercedesCard insurance package at a preferential price. You can also gain free entry to the Mercedes-Benz Museum simply by showing your VISA MercedesCard. Further information can be found at www.mercedes-benz.de/mercedescard¹

¹Information about the MercedesCard in Austria and Switzerland can be found on the Mercedes-Benz websites for these countries

Mercedes-Benz mobility. There will always be a helpful passenger in your new car: the assurance of carefree driving. Should you ever need assistance, however, the Mercedes-Benz Service24h is there for you. Just call the freephone service hotline on 00800 1 777 7777¹. The newly integrated telematics service Mercedes-Benz Contact² is even more customer-friendly: a touch of a button is all it takes to contact the Mercedes-Benz customer centre by phone. And if you wish all the relevant vehicle and position-related data can be sent at the same time, ensuring the fastest possible reaction time and rapid on-the-spot help. As standard and at no extra charge: the Mercedes-Benz mobility package Mobilo³. Whether you have lost your key, have had a breakdown which cannot be repaired immediately or if the vehicle is damaged as a result of an accident or vandalism, Mobilo gets you to your destination – anywhere in Europe, even if the vehicle is damaged as a result of an accident or vandalism. Should a repair take a little longer, we will even cover the cost

of an overnight stay. But don't get too excited – after all, it's very rare for a Mercedes to break down. Whatever the nature of your problem, one thing is sure: you will soon be able to resume your journey.

¹ Mobile phone rates vary according to service provider. Alternative number: +49 69 9530 7277

² Requires a factory-fitted radio linked up to a switched-on mobile phone. The only charge incurred is the cost of the mobile phone call to the landline network

³ When the warranty has expired Mobilo can be extended by another year for a maximum of 30 years, provided that regular maintenance is carried out by your Mercedes-Benz service partner

⁴ 9 ct / min. from Deutsche Telekom landlines, mobile-phone rates may vary

Mercedes-Benz Bank. If you have already chosen your dream car and want to remain financially flexible, you should make us your next port of call, whether it be for leasing, finance, insurance or service packages. Our “Private Leasing plus” scheme is a complete package comprising leasing, third-party insurance and fully-comprehensive insurance. “Business Leasing plus” for business customers works in much the same way, while our “Plus3 Financing” combines the low repayment rates of a financing scheme with the flexibility of leasing. You then have three options at the end of the contract: you can keep the car, sell it or return it to us for a guaranteed price and switch to a new model. We can also offer a range of investment products such as fixed-interest products, savings plans, investment funds or depository receipts. For details, please call 01803/32 22 65⁴ or visit www.mercedes-benz-bank.de



Time for another enriching experience

A Mercedes-Benz is most at home on the road. This is the only way to experience the effortlessly superior driving feel that lends every Mercedes model its inimitable class. Feel the power of efficient engines with low fuel consumption and precise steering, designed to put you right in the mood for driving. And experience what true comfort really is. The unique feeling of driving a Mercedes cannot be put into words, however. Which is precisely why we'd like to invite you to take a test drive. Your Mercedes-Benz dealer will be happy to make all the necessary arrangements for you. Simply visit www.mercedes-benz.com to locate the nearest Mercedes-Benz dealer in your country or region. We look forward to seeing you.

The website also offers an interactive tour, enabling you to take a closer look at your desired model. This simulation is the ideal way to acquaint yourself with your dream car. You can view key functions in detail, gain an insight into the car's inner workings or look at the benefits of each model. For further details, visit www.mercedes-benz.de/owners-manual

Now your mobile phone acts as a gateway to the whole Mercedes-Benz world. In addition to an overview of all passenger car models, there are insights into the entire brand world, not to mention a wealth of entertainment offers and direct links to a range of services at www.mercedes.mobi

Take-back of end-of-life vehicles. Coming full circle. At the end of its long life, you can return your C-Class to us for environment-friendly disposal in accordance with the EC End-Of-Life Vehicle Directive¹. But that day lies a long way off.

¹ Applies in accordance with national regulations to vehicles up to 3.5 tonnes gross weight. Mercedes-Benz passenger cars have met the statutory regulations governing the suitability of their design for reuse and recycling for a number of years now. A network of vehicle take-back depots and dismantlers has been established which will process your vehicle in an environment-friendly manner. The ways in which both vehicles and parts can be recovered are subject to ongoing development and improvement. Consequently, the C-Class will be able to comply with any future increases in the recycling quota within the stipulated time limits. For further information, please call 00800 1 777 7777

Please note: changes may have been made to the product since this brochure went to press (04.09.2009). The manufacturer reserves the right to make changes to the design, form, colour and specification during the delivery period, provided these changes, while taking into account the interests of the vendor, can be deemed reasonable with respect to the purchaser. Where the vendor or the manufacturer uses symbols or numbers to describe an order or the subject of an order, no rights may be derived solely from these. The illustrations may show accessories and items of optional equipment which are not part of standard specification. Colours may differ slightly from those shown, owing to the limitations of the printing process. This brochure has been compiled by Daimler AG of Germany and is distributed internationally. It provides a general indication of the range of models, features, optional extras, colours and/or services available in various countries. Some of the models, features, optional extras, colours and/or services may not be available in your country, or may only be available in a different specification. Additionally some models, features, optional extras, colours and/or services may only be available in combination with others. For current and more specific information in relation to the range of models, features, optional extras, colours and/or services available in your country, and their pricing, you should contact your nearest authorised Mercedes-Benz Passenger Car Dealer. www.mercedes-benz.com