

**ENGINE 272**

**i** The lines (A and 1) identify the sealant paths.

**i** The sealing surface must be cleaned. The sealant must only be applied to the specified surface in the form of a bead of height and width 2.0 mm ( $\pm 0.5$  mm). The sealant must be processed within 10 minutes. The sealant bead must not be spread. Use only the sealant indicated in the repair materials.

**Sealant application on oil pan bottom section on engine with front sump without code M005**



P01.45-2221-06

**Sealant application on oil pan top section on engine with front sump without code M005**

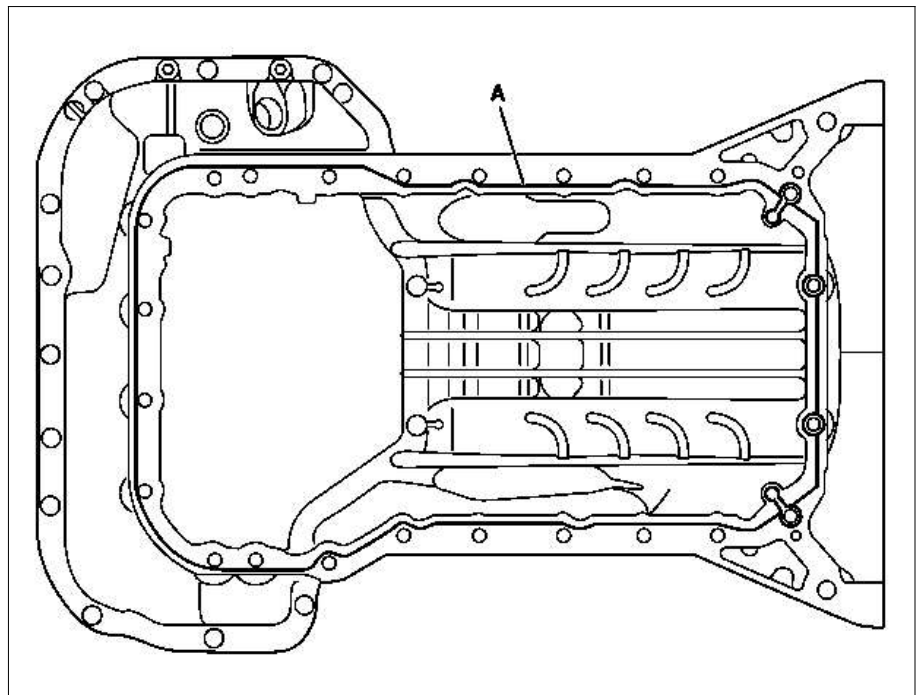

P01.45-2272-06

Sealant application on oil pan bottom section on engine with front sump with code M005

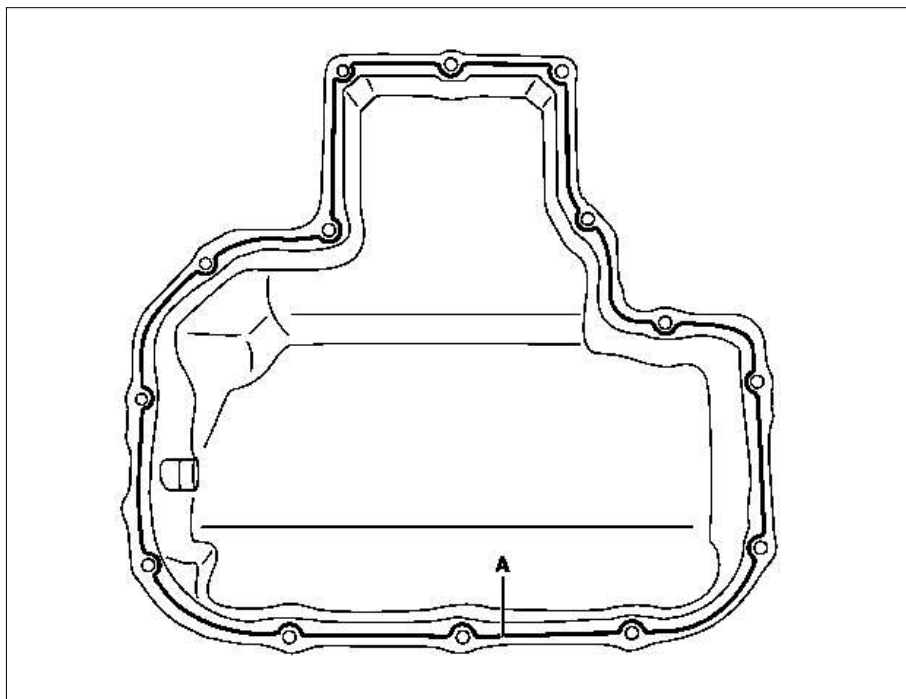

P01.45-2193-06

Sealant application on oil pan top section on engine with front sump with code M005

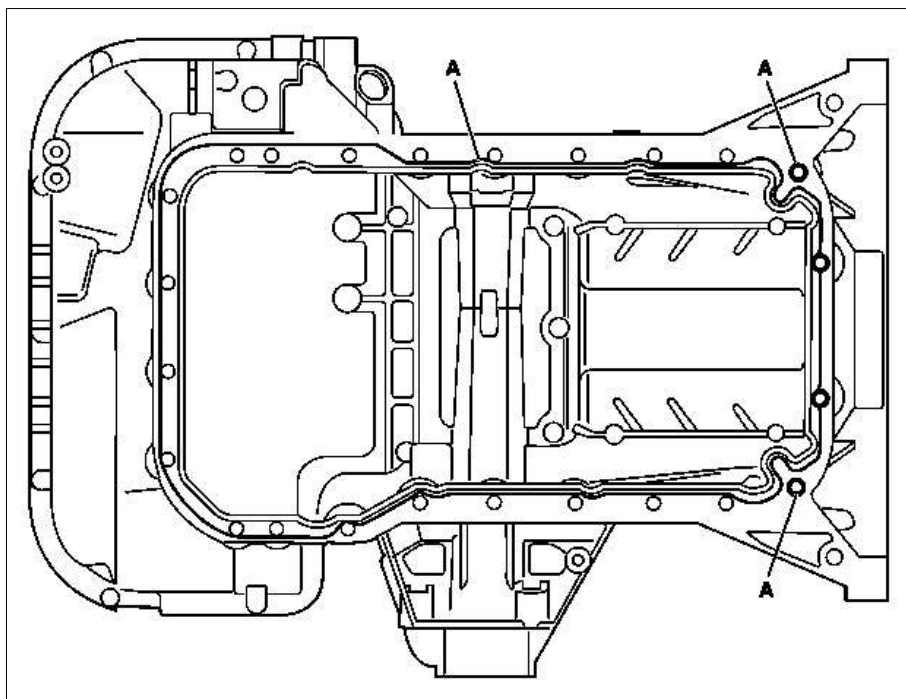

P01.45-2275-06

Sealant application on oil pan bottom section on engine with middle sump

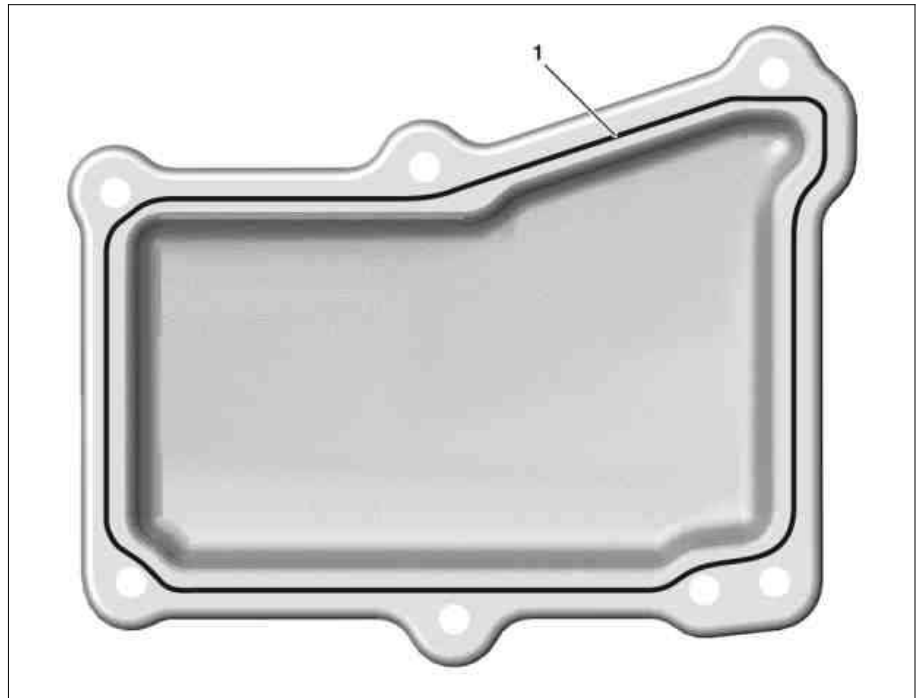

P01.45-2283-06

Sealant application on oil pan top section on engine with middle sump

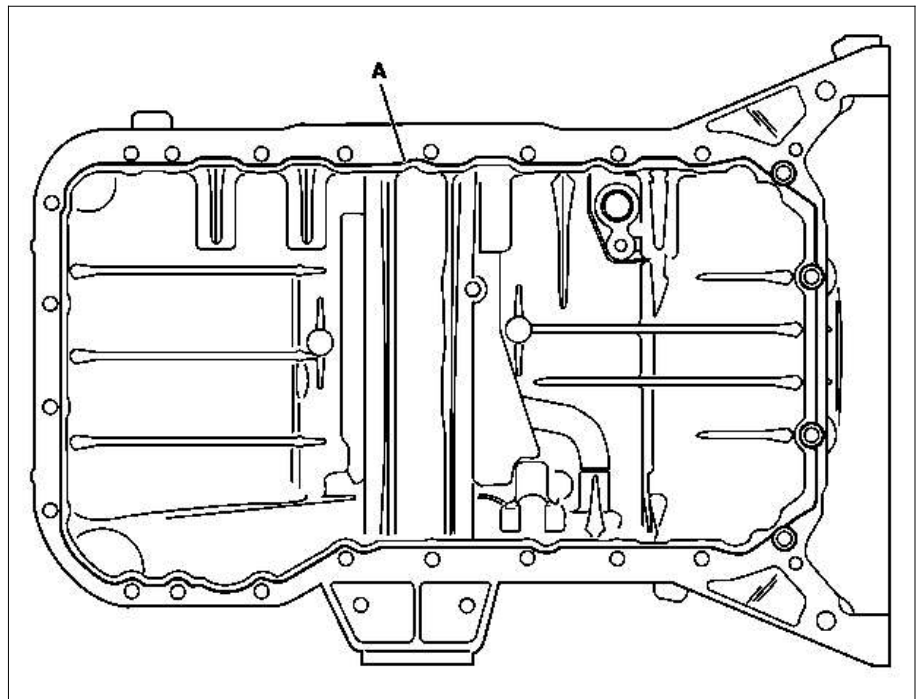

P01.45-2269-06

**Sealant application on oil pan bottom section on engine with rear sump**

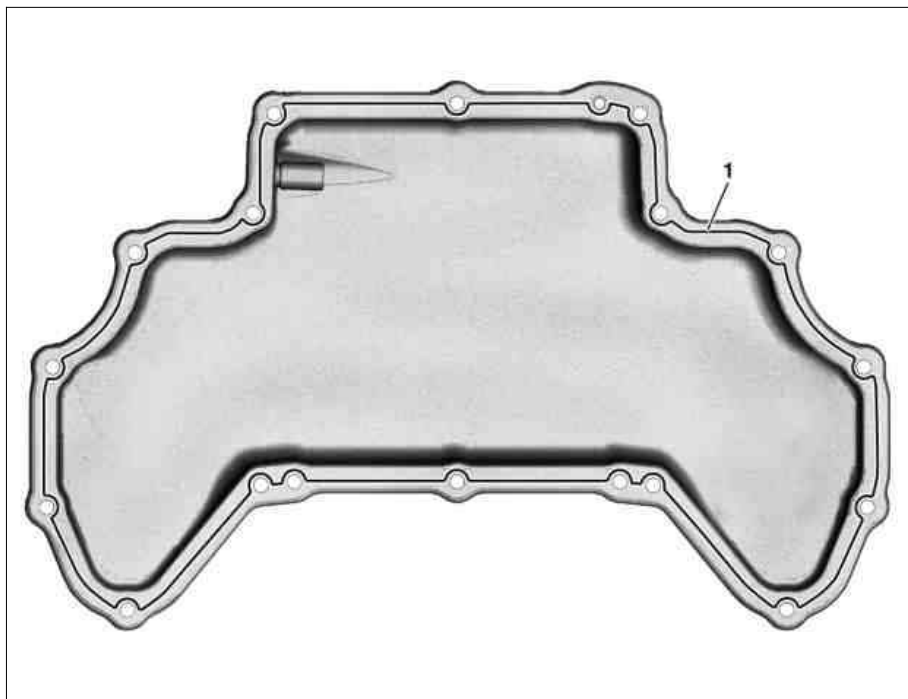

P01.45-2138-06

**Sealant application on oil pan top section on engine with rear sump**

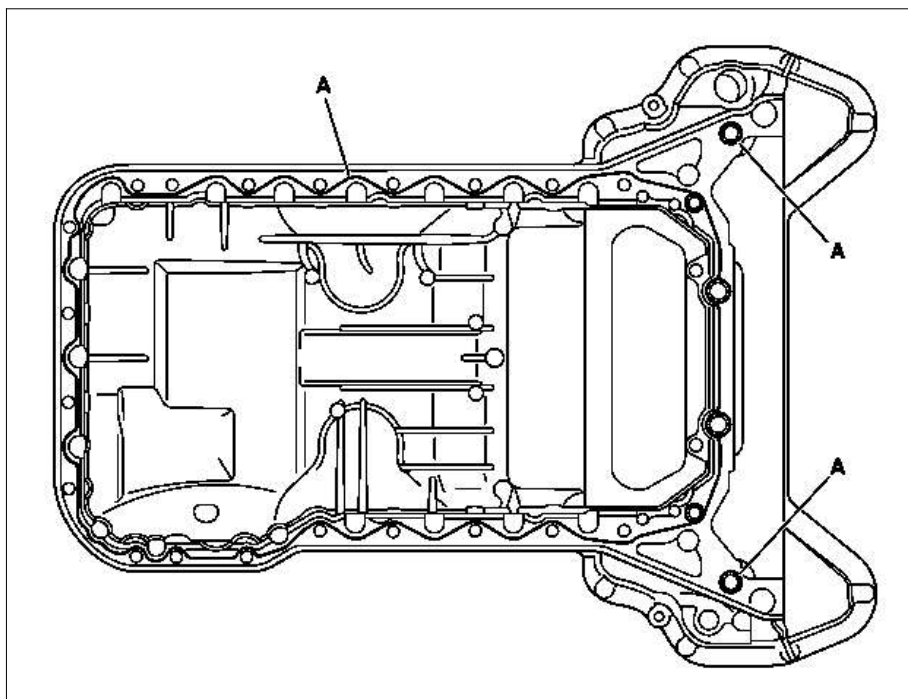

P01.45-2276-06