

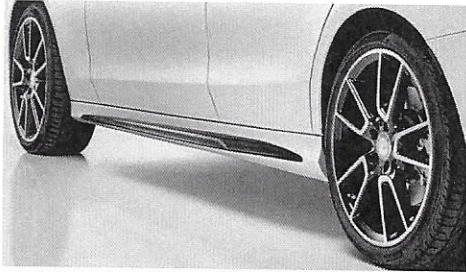

Mercedes-Benz

AMG side sill panels, complete set

black, high-sheen



Article number: A2056903004

Description

Distinctive side sill panels in high-gloss black for an individual, sporty look – specifically for vehicles with AMG bodystyling. Incorporated into the vehicle concept, these products are developed at AMG and individually tailored to each model in terms of design and aerodynamics. Simple to fit – no further painting required.

Suitable for the following vehicle models:

C-Class (A205 (09/16-)), (C205 (12/15-)), (S205 (09/14-)), (V205 (09/14-)), (W205 (03/14-))

Use in conjunction with the vehicle models listed can be limited by restrictions in respect to model year, engine or standard/special equipment. You can find out further information from your Mercedes-Benz partner.

AZ88.30-P-0017-01LW	Retrofit side spoiler on longitudinal member panel		
⚠ Danger!	Risk of poisoning caused by inhaling vapors or swallowing adhesive. Risk of injury caused by adhesive coming into contact with skin and eyes	Wear respiratory protection, protective gloves and safety glasses. Pour adhesive into suitable and appropriately marked containers only.	AS00.00-Z-0016-01A

- Model 205.0 (except 205.086/087/088/089), 205.2 (except 205.286/287/288/289), 205.3 (except 205.386/387/388/389) with code 772 (AMG styling package - front spoiler, side skirts and rear apron)
- Model 205.0 (except 205.086/087/088/089), 205.2 (except 205.286/287/288/289), 205.3 (except 205.386/387/388/389) with code P23 (EXCLUSIVE exterior)
- Model 205.0 (except 205.086/087/088/089), 205.2 (except 205.286/287/288/289), 205.3 (except 205.386/387/388/389) with code P31 (AMG Line exterior)

Repair materials

Number	Designation	Order number
BR00.45-Z-1025-02A	Terokal-9225 plastic repair adhesive 50 ml (pot life approx. 10 minutes) IDH no. 267081	Henkel AG & Co. KGaA Gutenbergstrasse 3 85748 Garching Germany Tel. +49 89 9268-0 Fax +49 89 9107890 www.Loctite.de
BR00.45-Z-1025-04A	Cleaner	A 005 989 19 71

i Installation is described on the right side. Analog procedure on left.

- Position drilling template (2) on longitudinal member paneling (1), align and press on firmly.
 - i** Ensure that the drilling template (2) is positioned in the assembly area on the longitudinal member paneling (1) without gaps (arrows A).
- Drill through longitudinal member paneling (1) through holes (3) in drilling template (2).
 - i** When drilling, hold down drilling template (2) on longitudinal member paneling (1).
 - i** Use drill bit with \varnothing_4 mm.
- Lay drilling template (2) down to side.
 - i** Completely remove plastic residues and drill chips.
- Completely clean longitudinal member paneling (1) in area to be glued.
 - ⚠** The area on the longitudinal member paneling (1) to be glued must be free of dust and grease. Otherwise adhesion problems may occur.

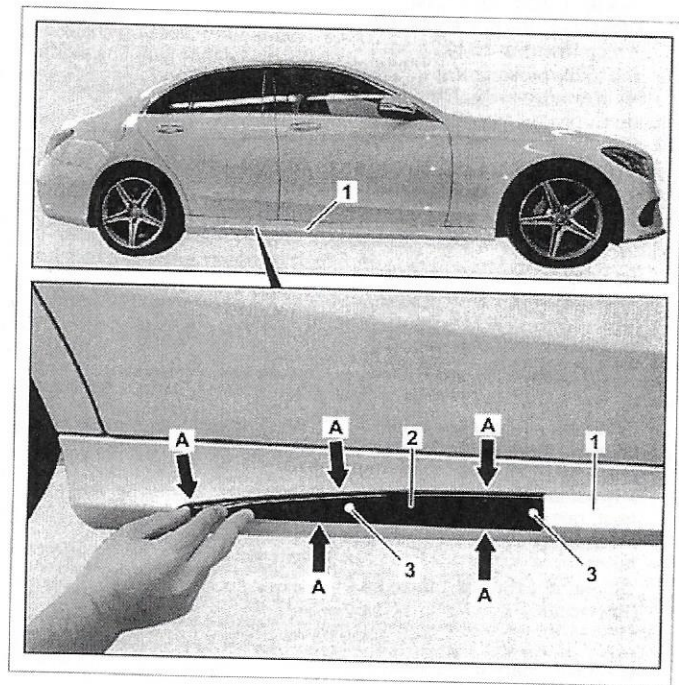

P88.30-2862-12

Shown on model 205.0

- 5 Slightly remove protective foils (6, 7, 8, 9, 10, 11) on adhesive strips at ends and bend 45° in direction of outer edge of carrier part (4).
- 6 Fix angled protective foils (6, 7, 8, 9, 10, 11) on adhesive strips at outer side of carrier part (4).
- 7 Position and align carrier part (4).

i For this purpose position blind rivets (5) in drilling hole in carrier part (4) and drilling holes in longitudinal member paneling (1) and center carrier part (4) in assembly area of longitudinal member paneling (1) without gaps (arrows B). After carrier plate (4) is centered and aligned, remove blind rivets (5).

- 8 Completely remove protective foils (6, 7, 8, 9, 10, 11) on adhesive strips starting at rear in increments of 15 to 20 cm and firmly press on carrier part (4) in remove protection foil area.
- 9 Slightly lift carrier part (4) off at front (arrow C) and attach additional strip of adhesive.
- 10 To increase process liability when installing carrier part (4), press carrier plate (4) onto longitudinal member paneling (1) with load roller (3M-MR1).

(B) When pressing on, apply pressure directly to adhesive strips on carrier part (4). Avoid any contact with moisture (e.g. frost, rain, fog, carwash) or any mechanical stress during first 24 hours. Otherwise adhesion problems may occur.

i Adjust load roller (3M-MR1) to 50 Nm.

i The maximum adhesive force is reached after approx. 72 hours at 20 °C.

- 11 Completely clean assembly area of carrier part (4).

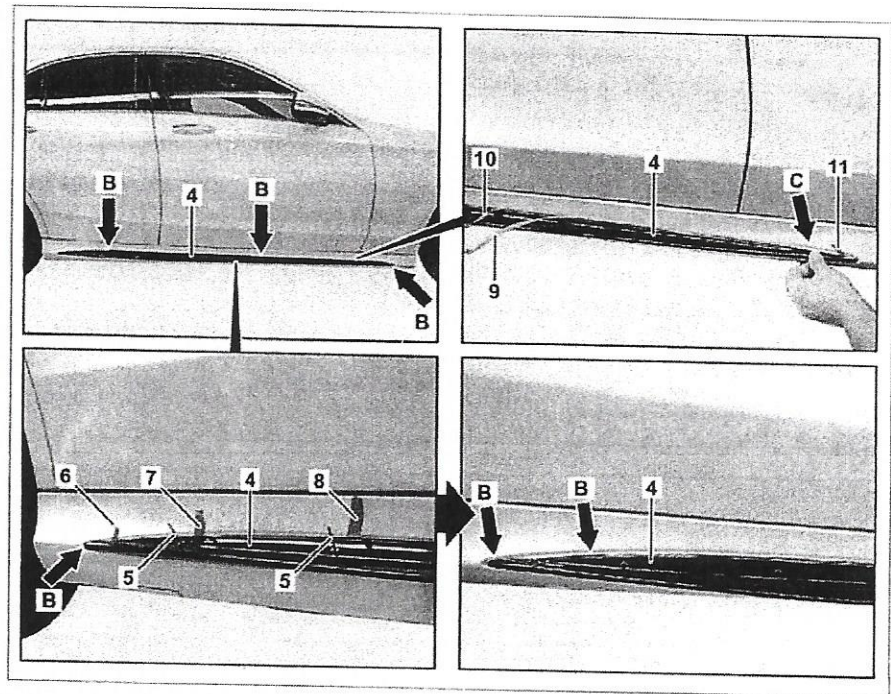

P88 30-2863-06

Shown on model 205.0

- 12 Slightly remove protective foils (13, 14, 15, 16) on adhesive strips at ends of and bend 45° in direction of outer edge of side spoiler (12).
- 13 Fasten angled protective foils (13, 14, 15, 16) on adhesive strips to outside of side spoiler (12).

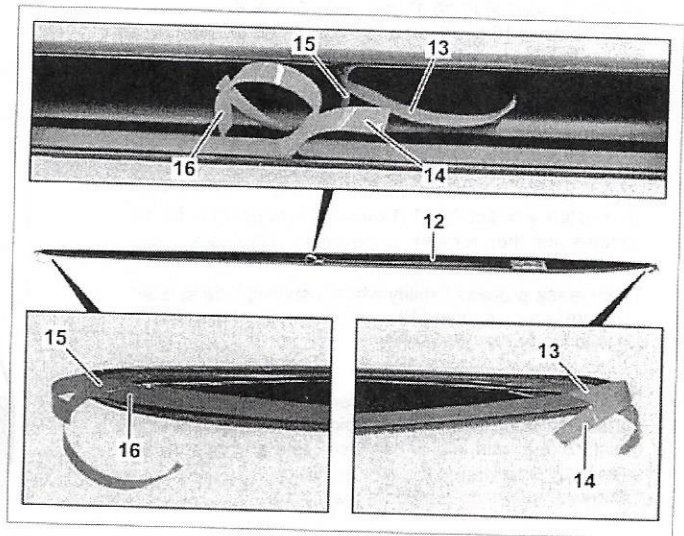

P88 30-2864-11

- 14 Install side spoiler (12) on longitudinal member (1), position and align.

i For this purpose position blind rivet (5) in drill hole through side spoiler (12) and position carrier part (4) and center side spoiler (12) in assembly area of longitudinal member panel (1) without gaps. After centering and aligning side spoiler (12), remove blind rivet (5).

Shown on model 205.0

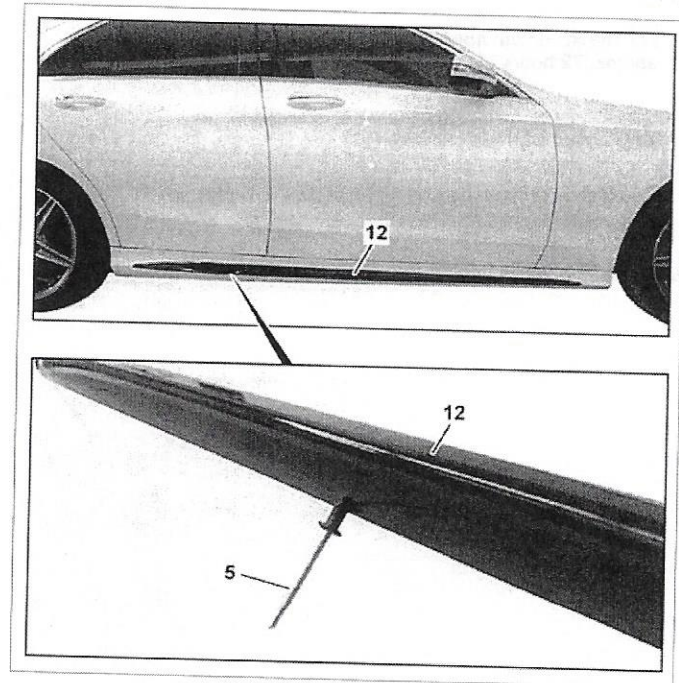

P88 30-2859-12

15 Completely remove protective foils (13, 14, 15, 16) on adhesive strips starting at rear toward front in increments of 15 to 20 cm and firmly press on side spoiler (12) in removed protective foil area.

16 Slightly lift side spoiler (12) at front (arrow D) and apply additional strip between carrier part (4) and side spoiler (12) and press on firmly.

i Fasten side spoiler (12) with crepe paper (17) for 10 minutes and then remove crepe paper (17) again.

17 To increase process liability when installing side spoiler (12), press side spoiler (12) onto longitudinal member (1) with load roller (3M-MR1).

ⓘ When pressing on, press directly on bonding surface on side spoiler (12). Avoid any contact with moisture (e.g. rain, fog or carwash), and all mechanical stress and frost during the first 24 hours. Otherwise adhesion problems may occur.

i Set load roller (3M-MR1) pressure to 50 N.

i The maximum adhesive force is reached after approx. 72 hours at 20 °C.

18 Completely clean assembly area of side spoiler on longitudinal member paneling (12).

19 Completely remove packaging protective foils (18) on side spoiler longitudinal member paneling (12).

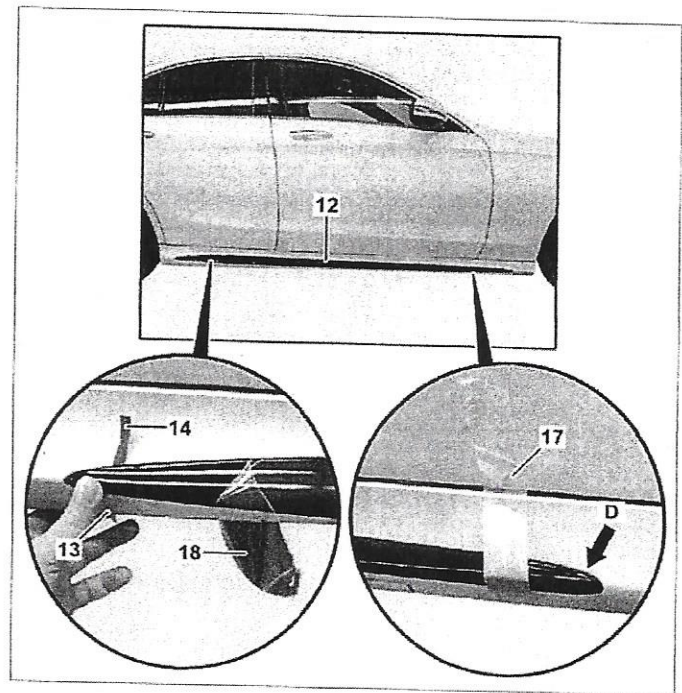

P88 30-2865-12

Shown on model 205.0