

MODELS 203 (except 203.081 /084 /087 /092 /281 /284)

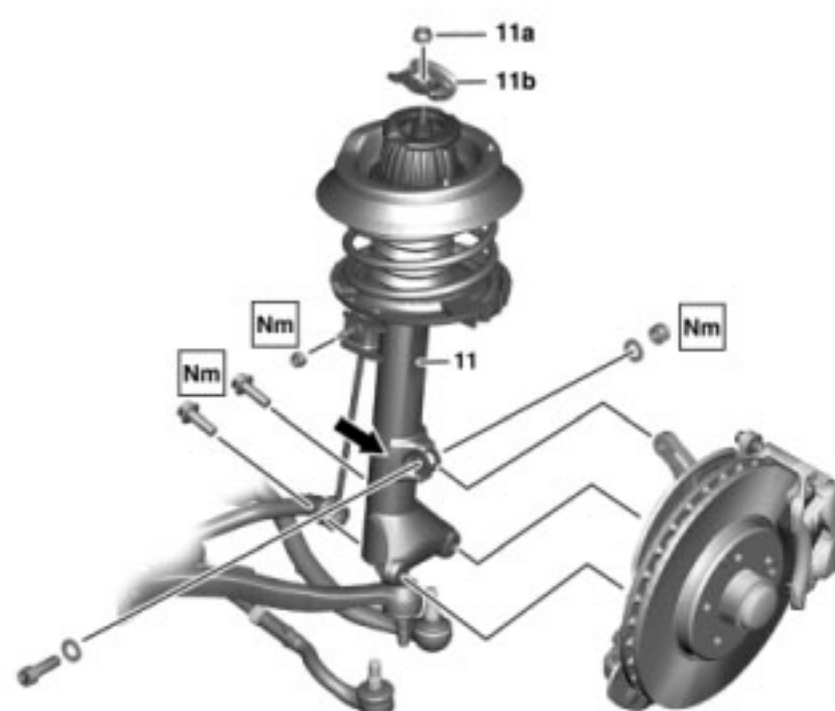
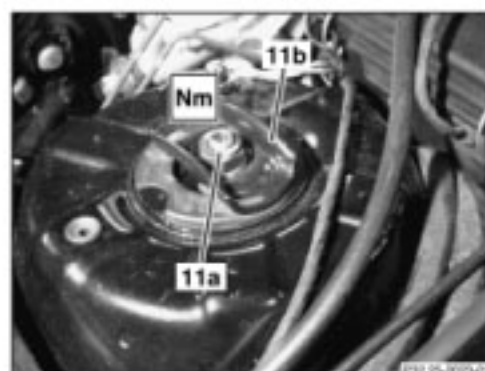

P32.25-2029-09

Modification notes

| | | | |
|----------|-----------------------------------|---|--------------------|
| 16.10.02 | Value changed from 45 Nm to 60 Nm | Value revised in row BA32.20-P-1004-02B on model 203 except 203.081/084/281/284 | BA32.20-P-1004-02B |
|----------|-----------------------------------|---|--------------------|

| Icons | Remove/install | | |
|-------|--|---|--|
| | Danger! | Risk of death caused by vehicle slipping or toppling off of the lifting platform. | Align vehicle between the columns of the lifting platform and position the four support plates at the lifting platform support points specified by the vehicle manufacturer. |
| | Notes on self-locking nuts and bolts | All models | AS00.00-Z-0010-01A |
| | 1 Remove the front wheels | | |
| | Remove/install wheels, rotate if necessary | | AP40.10-P-4050Z |
| | 2 Unclip bracket for brake hose (arrow) on suspension strut (11) | Remove tie straps Push bracket (arrow) on brake hose along as far as possible upwards and fasten. | |
| | 3 Detach torsion bar link rod from suspension strut (11) | | BA32.20-P-1004-02B |
| | 4 Detach suspension strut (11) from wheel carrier | Model 203: ↓ | |
| | | | BA32.25-P-1010-01B |
| | | | BA32.25-P-1008-01B |
| | 5 Unscrew nut holding rebound stop (11a) on strut tower | Secure suspension strut (11) to prevent it from falling down. | |
| | | Model 203: ↓ | |
| | | | BA32.25-P-1006-01B |
| | 6 Remove spring strut (11) | | |
| | 7 Install in the reverse order | | |

Front axle shock absorber

| Number | Designation | | Model 203 without 4MATIC |
|--------------------|---|---------|--------------------------|
| BA32.25-P-1006-01B | Nut, rebound stop to piston rod | Nm | 60 |
| BA32.25-P-1008-01B | Self-locking bolt, suspension strut to steering knuckle at bottom | Nm | 110 |
| BA32.25-P-1010-01B | Self-locking nut, suspension strut to steering knuckle at top | Stage 1 | Nm 120 |
| | | Stage 2 | 4° 90 |

Front axle torsion strut

| Number | Designation | | Models 203 except models 203.081/084/087/092/281/284 |
|--------------------|--|---------|--|
| BA32.20-P-1004-02B | Self-locking nut, connecting rod to spring strut | M10 | Nm 60 |
| | | M10×1.5 | Nm - |
| | | M12×1.5 | Nm - |
| | | M12 | Nm - |