

## A/C - Various Compressor Noise With A/C ON

Date: March 10, 2009

Order No.: S-B-83.55/87f

Supersedes: S-B-83.55/87e dated Nov. 20, 2008

Group: 83

Revision	Date	Purpose
f	3/10/09	Content Updated
e	11/20/08	Applicable Models Updated (Added 230 Equipped with M113 Engine)
d	9/25/08	Warranty Information Updated (Op Code 83-7624)
c	8/12/08	Applicable Models Updated (OM642 Models Added) / Model 203.040/740 Removed (refer to DTB P-B-83.55/119) / Figure 3a Added / Note Updated after Step 15
b	11/30/07	Model 203.040/740 and Respective Information Added
a	8/7/07	Addition of Mandatory Tool (Step 13)
-	5/3/07	Initial issue

Zoom

Sized for Print

### Revision History

**All Model 163, 203, 209, 211 and 220, Equipped with M112 Engine**  
**All Model 163, 164, 171, 203, 209, 211, 215, 219, 220, 230 and 251, Equipped with M113 Engine**  
**All Model 164, 171, 203, 209, 211 and 251 Equipped with M272 Engine**  
**All Model 164, 209, 211, 216, 219, 221 and 251 Equipped with M273 Engine**  
**All Model 164 and 251, Equipped with M272/273 Engine**  
**All Model 164, 211 and 251, Equipped with OM642 Engine**  
**All Model Years**

Zoom

Sized for Print

## SUBJECT

Replacement of [Refrigerant](#) Compressor Belt Pulley Due to Noise Complaints If you receive customer reports in the above model vehicles of noises at the refrigerant compressor with air conditioning activated and deactivated, the cause could be a defective belt pulley or belt pulley bearing. The pulley and pulley bearing can be diagnosed and replaced with the compressor still installed in the vehicle by following the procedures below.

1. Locate the noise by duplicating the conditions under which the complaint occurred.
2. If there is also a cooling performance complaint, the noise could be caused by low [refrigerant](#) level, perform a Refrigerant Circuit Test as per SDS and follow instructions for corrective actions.
3. Before the belt pulley on the [refrigerant](#) compressor is replaced, verify that the following components in the belt drive are not the source of the noise and repair as required.

^ Alternator

^ Power steering pump

^ Guide pulleys / tensioner pulleys

^ Water pump

4. If there is a whining noise that is RPM-dependant which is present with the air conditioning on AND off and is determined to be caused by the tensioner pulleys, guide pulleys or [refrigerant](#) compressor, continue with step 5.

### **Note:**

Make sure that the AC is SHUT OFF! On the push button unit, select "AC off" then "OFF" to turn the Climate System off, then select climate system on. The compressor should now be off. To see more details on the various push button units, please refer to the climate book, section 2.1 for each model.

Engines M112/113/272/273

5. Remove the poly-V-belt from the [refrigerant](#) compressor.

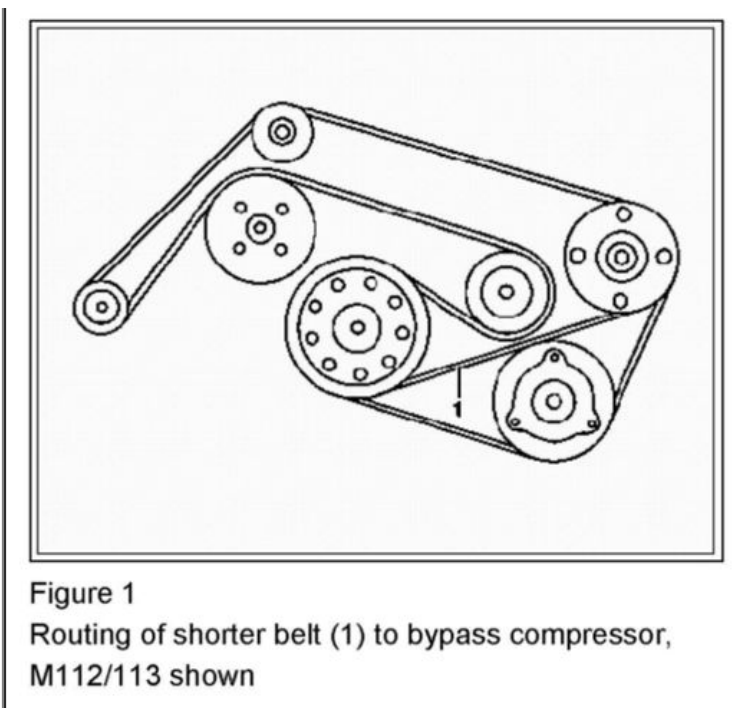

Zoom

Sized for Print

6. Install shorter belt to bypass the compressor. Route belt as shown in Figure 1.

Engines M112/113 - 20 x 2315 to 2325 mm (A011 997 86 92 or A 011 997 96 92)  
Engines M272/273 - 20 x 2330 to 2340 mm (A011 997 04 92)

**Note:**

A short test belt for OM642 is currently not available.

**Note:**

The belts can be sourced locally or by MB part number. The belts must be purchased to diagnose AC [compressor pulley](#) noise and are not to be submitted on a warranty claim.

7. Run the engine with the short belt installed. If the noise is still present, check whether the tensioner and/or guide pulleys are the source of the noise. Replace as necessary the defective tensioner and/or guide pulleys.

8. If the noise is no longer present, allow the engine to cool and proceed to step 10.

9. Replace the [compressor pulley](#) as follows.

**Note:**

It is not necessary to remove the compressor or evacuate the refrigeration circuit. Refer to WIS document AR83.55-P-7685B

10. Remove the pulley-V-belt. Determine if the diameter of the pulley is 100 mm or 110 mm.

11. Raise the vehicle and remove the lower engine compartment paneling.



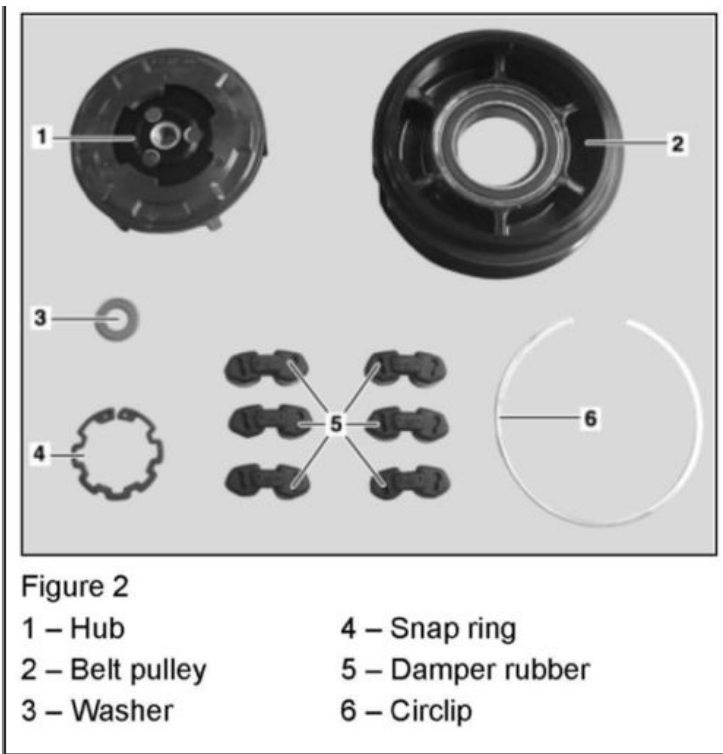

Zoom      Sized for Print

12. Refer to Figure 2 for component number references. Remove the belt pulley circlip (Figure 2, Part 6). With plastic belt pulleys, it is possible to insert a screwdriver under the circlip (Figure 2, Part 6) and pry it out of the groove.

13. Remove hub (Figure 2, Part 1) using a socket and counter hold tool W112 589 07 40 00. Use a small magnet to remove flat washer from shaft.

**Note:**  
 There are two versions of the compressor shaft, a 7mm hex and one with two flats. The shaft with two flats requires the use of socket W112 589 02 09 00. To loosen 7mm hex head, ensure that proper METRIC tool is utilized. To loosen the pulley:

**Warning!**  
 It is not a left hand thread!

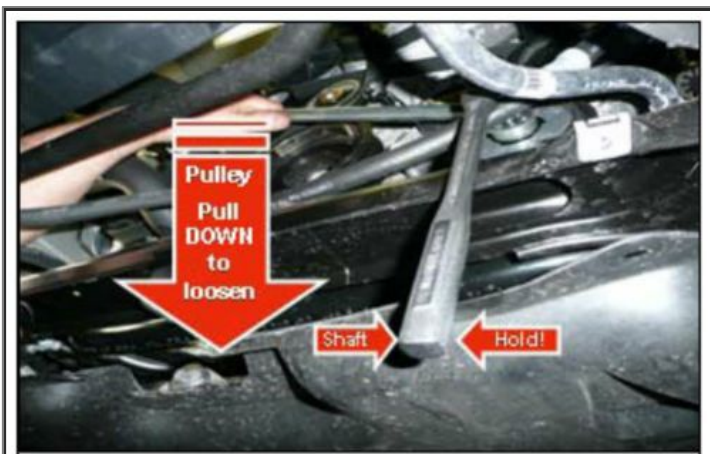

Figure 3a

**Method A** (Preferred and shown in picture above): Hold the compressor shaft stationary and turn the drive hub counter clockwise to loosen (Figure 3a). Turn the hub clockwise to tighten.

**Method B:** Hold the drive hub stationary and turn the compressor shaft clockwise to loosen. Turn counter clockwise to tighten.

14. Remove snap ring (Figure 2, Part 4) for pulley bearing.

15. Remove belt pulley (Figure 2, Part 2) from the end of compressor housing.

**Note:**

Do not apply a pulling force in an axial direction to the [refrigerant](#) compressor shaft.

Components damaged due to improper repair procedures may be subject to debit.

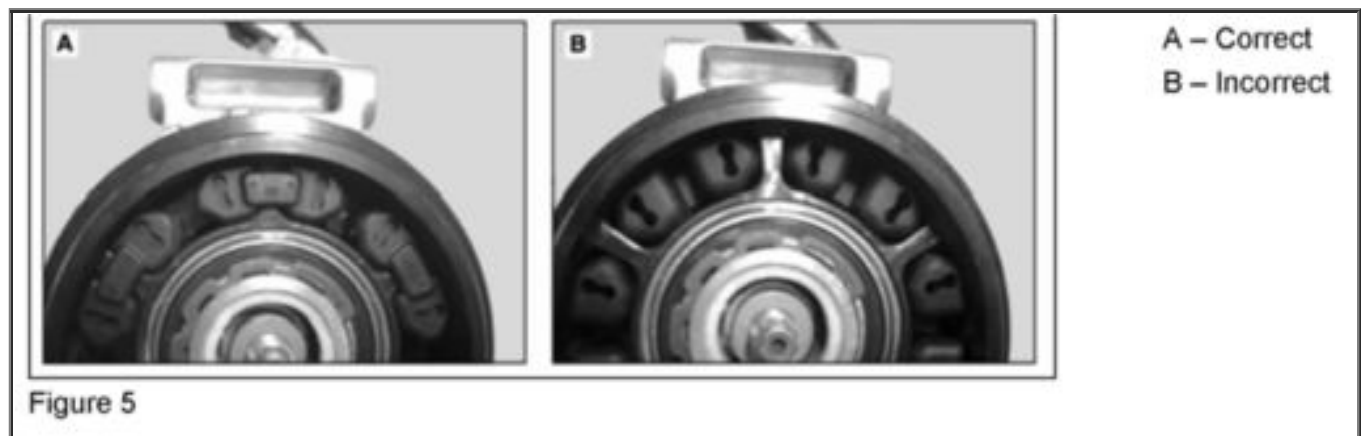
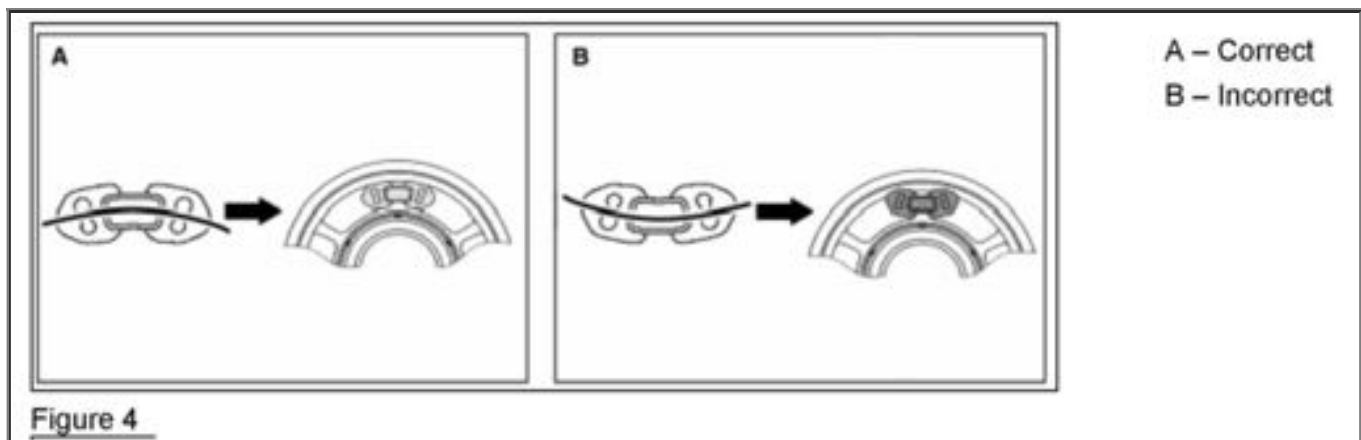

Assemble the rubber dampers (Figure 2, Part 5) into new pulley the as shown in example A in Figure 4 and Figure 5. Make note of the direction of the curvature of the rubber dampers and install them over the reinforcing webs in the pulley, not in the spaces

between the webs.

16. Install new belt pulley (Figure 2, Part 2) onto the end of compressor housing. Make sure it is the same diameter as the original, 100 mm, 110 mm.

17. Install the snap ring (Figure 2, Part 4) for pulley bearing with its flat side facing the [refrigerant](#) compressor. Make sure the snap ring is seated correctly in the groove.

**Note:**

Use snap ring pliers with 90° tips that have a minimum reach of 19 mm (0.75").

18. Install washer (Figure 2, Part 3). Make sure it is flat against the shoulder of the shaft.

19. Install hub (Figure 2, Part 1) so the drive fingers are inserted into the gaps between the ends of the rubber dampers. Screw the hub onto the compressor shaft clockwise and torque to 35 nm. The hub continues to tighten when in the compressor is in operation.

20. Install circlip (Figure 2, Part 6) into the belt pulley. Make sure it is seated in the groove of the pulley.

21. Install a new standard length poly-V-belt. Start engine and verify correct belt operation.

22. Install lower engine paneling.

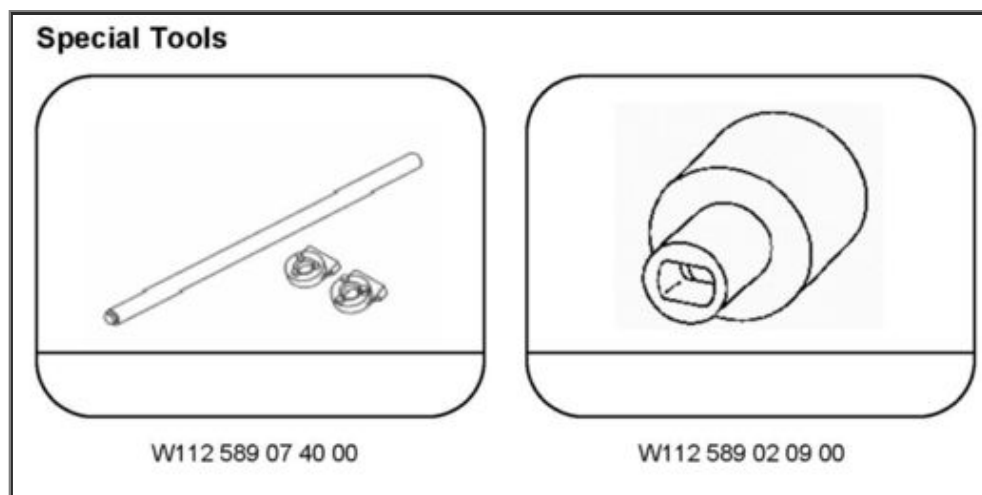

Zoom

Sized for Print

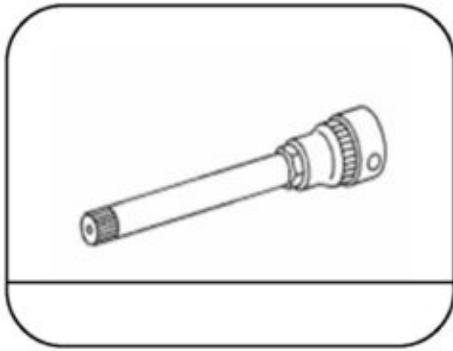

W601 589 00 10 00

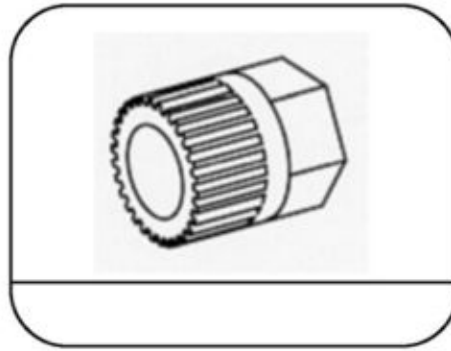

W602 589 00 10 00

MBUSA Special Tool No.	Category	Description
W112 589 07 40 00	B	Counter holder
W112 589 02 09 00	B	Socket
W601 589 00 10 00	B	Socket M10
W602 589 00 10 00	B	Socket Wrench

\*Tools have been automatically shipped to all dealers.

Zoom

Sized for Print

## Special Tools

Qty.	Part Name	Part Number
1	Belt pulley 100 mm diameter	A000 234 13 12
1	Belt pulley 110 mm diameter	A000 234 14 12
1	Belt pulley 120mm diameter	A000 234 16 12
1	Belt pulley 7 ribs (OM642)	A000 234 21 12
1	Belt pulley 8 ribs (OM642)	A000 234 22 12
1	Belt (2315 mm for testing M112/113)	A011 997 96 92 *
1	Belt (2330 mm for testing M272/273)	A011 997 04 92 *

\* The belts can be sourced locally or by MB part number. The belts must be purchased to diagnose AC compressor pulley noise and are not to be submitted on a warranty claim.

Zoom

Sized for Print

## Parts Information

### Note:

The following allowable labor operations should be used when submitting a warranty claim for this repair. This information has been generated on November 20, 2008. Please refer to Netstar --> Star TekInfo --> Star Time for the most current labor time allowance.





**Operation:** If cooling performance is cause:  
 Refrigerant circuit test, perform (83-0000)  
 Determining source of noise:  
 Engine noise(s), locate (94-1013)  
 V belt replace single belt drive, tensioner assembly without tension lever (13-1202)  
 Replacement of noisy parts:  
 Belt tensioner – for single belt drive, R&R/replace (13-3200)  
 Guide pulley A – V-belt, replace (13-3350)  
 Guide pulley – V-belt, replace (13-0000)  
 Engine compartment panel, bottom – front part, R&R (61-1071)  
 Engine compartment panels – bottom (all), R&R (61-1069)  
 Clutch pulley – for A/C compressor, replace (after test) (83-7624)  
 A/C pulley, replace (83-0000)

Zoom

Sized for Print

Damage Code	Operation Number	Time (hrs.)	Model Indicator (s)	
Only can be claimed if a cooling performance complaint is documented.  Appropriate Damage Code Required  List on appropriate line.	83 0000	0.2 hrs.	AA, AD, BA, BB, BD, DA, EA, EB, J2, K1, K2, K3, K4, K5, M1, M2, M5, M6, M7, M9, N1, N3, N5, P1, P2, P3, P4, P6, P7, P8, P9, Q2, Q4, Q5, Q6, Q7, Q8, Q9, QA, R1, R2, R7, S1, S2, S3, S4, S5, S6, S7, S8, SA, SB, T1, T2, T3, T4, T5, T7, T8, T9, TA, TC, U1, U3, U4, U5, U6, U7, X1, X2, X3, Y1, Y2, Y3, Z1, Z2, Z4	
	OR	94 1013	0.4 hrs.	AA, AD, BA, BB, BD, DA, EA, EB, J2, K1, K2, K3, K4, K5, M1, M2, M5, M6, M7, M9, N1, N3, N5, P1, P2, P3, P4, P6, P7, P8, P9, Q2, Q4, Q5, Q6, Q7, Q8, Q9, QA, R1, R2, R7, S1, S2, S3, S4, S5, S6, S7, S8, SA, SB, T1, T2, T3, T4, T5, T7, T8, T9, TA, TC, U1, U3, U4, U5, U6, U7, X1, X2, X3, Y1, Y2, Y3, Z1, Z2, Z4
		13 1202	0.4 hrs.	J2, M1, M2, M5, M6, M7, N1
			0.5 hrs.	AA, AD, DA, N3, R1, S1, S2, S3, S4, S5, S6, S7, S8, T1, T2, T3, T4, T5, T7, T8, T9, TA, U1, U3, U4, U6, U7, Y1, Y3
			0.6 hrs.	BA, BB, EA, P1, P2, P3, P4, Q2, Q4, Q5, Q6, Q7, Q8, Q9, QA, SA, SB, X2, Z1, Z2
			0.7 hrs.	BD, EB, K1, K2, K3, K4, K5, P6, P7, P8, P9, TC, X1, X3, Z4
			0.8 hrs.	U5, Y2
	AND		0.9 hrs.	M9, N5, R2, R7
20249 36	13 3200	0.7 hrs.	K1, K2, K3, K3, K4, K5, R1, S1, S4	
			0.8 hrs.	AA, AD, BA, BB, BD, DA, EB, P1, P2, P3, P4, Q2, Q4, S2, S3, S5, S6, S7, S8, T7, T8, T9, TA, TC, U6, U7, X2, Y1, Y3, Z1, Z2, Z4
			0.9 hrs.	P6, P7, P8, P9, Q5, Q6, Q7, Q8, Q9, QA, T3, U5, Y2
			1.0 hrs.	M9, N5, R2, R7, T1, T2, T4, T5, U1, U3, U4
			1.1 hrs.	X1, X3
			1.4 hrs.	EA
			1.5 hrs.	SA, SB
	OR		1.6 hrs.	J2, M1, M2, M5, M6, M7, N1, N3

Zoom

Sized for Print



Damage Code	Operation Number	Time (hrs.)	Model Indicator (s)
20253 36	13 3350	0.6 hrs	Z1
		0.7 hrs.	AA, AD, DA, EA, S7, S8, SA, SB, T7, T8, T9, TA, U6, U7, X2, Y3
		0.8 hrs.	Q6, Q7, Q8, Q9, QA
		0.9 hrs.	X1, X2
OR	13 0000	0.0 hrs. *	J2, M1, M2, M5, M6, M7, M9, N1, N3, N5, P1, P2, P3, P4, P6, P7, P8, P9, Q2, Q4, Q5, R1, R2, R7, S1, S2, S3, S4, S5, S6, T1, T2, T3, T4, T5, U1, U3, U4, U5, Y1, Y2
	83525 36	61 1071	0.2 hrs.
		0.3 hrs.	AA, AD, DA, J2, M1, M2, M5, M6, M7, M9, N1, N3, N5, T1, T2, T3, T4, T5, T7, T8, T9, TA, U1, U3, U4, U5, U6, U7, Y1, Y2, Y3
	61 1069	0.7 hrs.	R1, R2, R7
	83 7624	0.0 hrs. *	AA, AD, DA, J2, M1, M2, M5, M6, M7, M9, N1, N3, N5
		0.4 hrs.	T1, T2, T3, T4, T5
		0.6 hrs.	K1, K2, K3, K4, K5, S1, S2, S3, S4, S5, S6, S7, S8, SA, SB, T7, T8, T9, TA, U1, U3, U4, U6, U7, Y1, Y3
		0.7 hrs.	P1, P2, P3, P4, Q2, Q4, Q5, Q6, Q7, Q8, Q9, QA
		0.8 hrs.	P6, P7, P8, P9, X1, X2, X3, Y2
		0.9 hrs.	U5
	83 0000	0.0 hrs. *	BA, BB, BD, EA, EB, R1, R2, R7, TC, Z1, Z2, Z4

\* Separate time punch required. Ensure that punches are labeled as NON time.

Zoom

Sized for Print

In Case of Warranty, use the table above.