

ENGINE 112 in MODELS 170, 202, 203, 208.365 /465, 209, 210, 220

ENGINE 113 in MODEL 203, 209, 220

ENGINE 113.981 in MODEL 163.174

ENGINE 113.987 in MODEL 209.376

ENGINE 113.965 in MODEL 163.175

ENGINE 113.989 in MODEL 171.473

## Shown on engine 112

- 1 Electric fan
- 2 Poly-V-belt
- 3 Fan shroud
- 4 Tensioning device
- 5 Bolts of tensioning device
- 6 Drift or pin
- 7 Shock absorber
- 8 Bolts of shock absorber

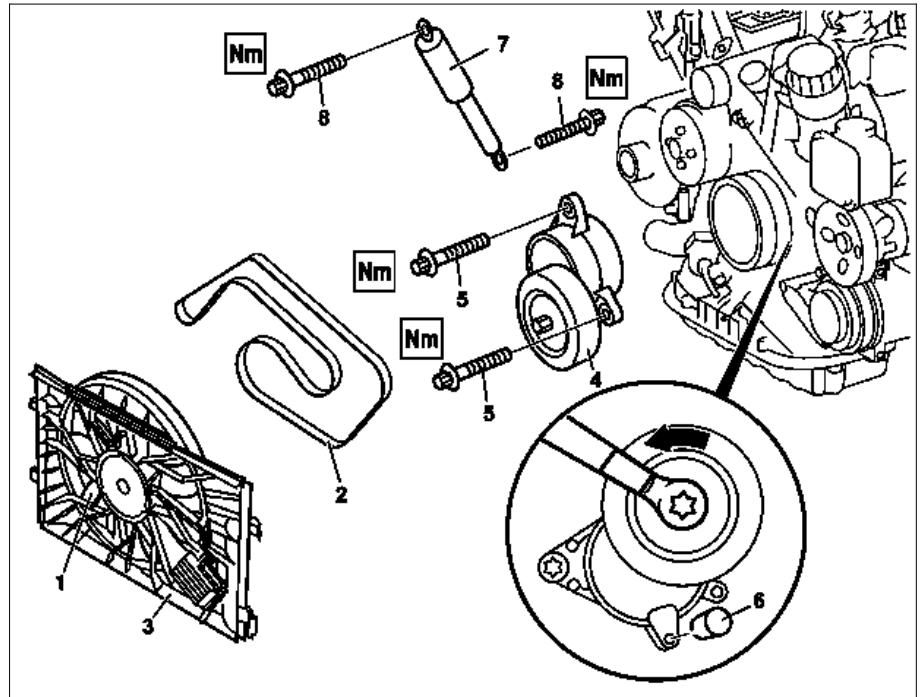

P13.25-2008-06

☒ ☒	Remove/install		
⚠ <b>Danger!</b>	<b>Risk of death</b> caused by vehicle slipping or toppling off of the lifting platform.	Align vehicle between the columns of the and position the four support plates below the lifting platform support points specified by the vehicle manufacturer.	AS00.00-Z-0010-01A
1.1	Remove fan shroud (3)	Model 220	AR20.40-P-6800AB
2.1	Remove electric fan (1)	Model 170 Model 163.174/175 Model 209, 203 except model 203.076/276 Model 203.076/276	AR20.40-P-5000SV AR20.40-P-5000GH AR20.40-P-5000PV AR20.40-P-5000AC
3	Remove poly V-belt (2)	Model 163.174/175 Model 202, 208, 210 Model 220 except 220.074/174 Model 220.074/174 Model 170 except 170.466 Model 203 except 203.065/265065/265 Model 209 Model 171.473 Model 170.466 Model 203.065/265	AR13.22-P-1202BA  AR13.22-P-1202R AR13.22-P-1202SV AR13.22-P-1202PV  AR13.22-P-1202SVK
4	Rotate tensioning pulley in anti-clockwise direction and lock	ⓘ Lock tensioning pulley with drift or pin (6) (diameter 5 mm).	
5.1	Unbolt shock absorber (7) at coolant pump	Only model 170, 202, 203, 210 with manual transmission: ↓ Nm Shock absorber of belt tensioning device at the coolant pump housing ☑ External torx set	*BA13.25-P-1004-01M  *001589760900
6	Unscrew bolts of tensioning device (5)	Engine 112: ↓ Nm Self-tapping screw for belt tensioner to timing case cover ⓘ Engine 113 except 113.987/988/991: ↓ Nm Self-tapping screw for belt tensioner to timing case cover ⓘ Engine 113.991: ↓	*BA13.25-P-1001-01M  *BA13.25-P-1001-01D

		Bolt of belt tensioner to timing case cover External torx set	*BA13.25-P-1005-01D *001589760900
7	Remove tensioning device (4)		
8.1	Unscrew shock absorber (7) at tensioning device (4)	Model 170, 202, 203, 209, 210 with manual transmission: ↓ Shock absorber of the belt tensioning device at the belt tensioning device External torx set	*BA13.25-P-1003-01M *001589760900
9	Install in the reverse order		

**Belt tensioning device**

Number	Designation	Engine
		112.910/911/912 /913/914/915/ 916/917/920/ 921/922/923/ 940/941/942/ 943/944/945/ 946/947/949/ 953/954/955/ 960/961/970/ 972/973/975
BA13.25-P-1001-01M	Self-tapping bolt of belt tensioner to timing case cover	Thread not pre-tapped Nm 35
		Thread pre-tapped Nm 25
BA13.25-P-1003-01M	Shock absorber of belt tensioning device to belt tensioning device	Nm 25
BA13.25-P-1004-01M	Shock absorber of belt tensioning device to coolant pump housing	Nm 35

**Belt tensioning device**

Number	Designation	Engine	Engine	Engine
		113.940/941/ 942/943/944/ 945/946/948/ 960/961/962/ 963/964/965/ 966/967/968/ 969/971/980/ 981/982/984/ 986/987/988	113.990/ 991/992/ 993/995	113.989
BA13.25-P-1001-01D	Self-tapping bolt of belt tensioner to timing case cover	Thread not pre-tapped Nm 35	35	35
		Thread pre-tapped Nm 25	25	25
BA13.25-P-1005-01D	Bolt of belt tensioner to timing case cover	M7×25 Nm 35	35	35

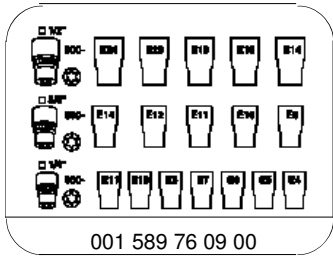

001 589 76 09 00

External Torx set