

# Air Conditioner / HVAC W203 Stepper Motor Repair

## PART 1 OF 3

<http://mbworld.org/forums/c-class-w203/177068-noisy-air-conditioner-stepper-motor-replacement-clicking-hissing.html>

<http://mbworld.org/forums/c32-amg-c55-amg-w203/449471-famous-ac-clicking-noise-ac-footwell-damper-linkage-replacement-diy-details-steps.html>

Great BIG thanks to [Racin\\_fool](#), [liveniceguy](#) and [Wilsophia](#) for the write up and pictures!!!

**DIY Starts on page 5**  
**Upper Dash Removal page 25**

W203 & 463 HVAC MB Technical Training Aid  
<http://www.buellwinkle.com/HVAC-W203.pdf>

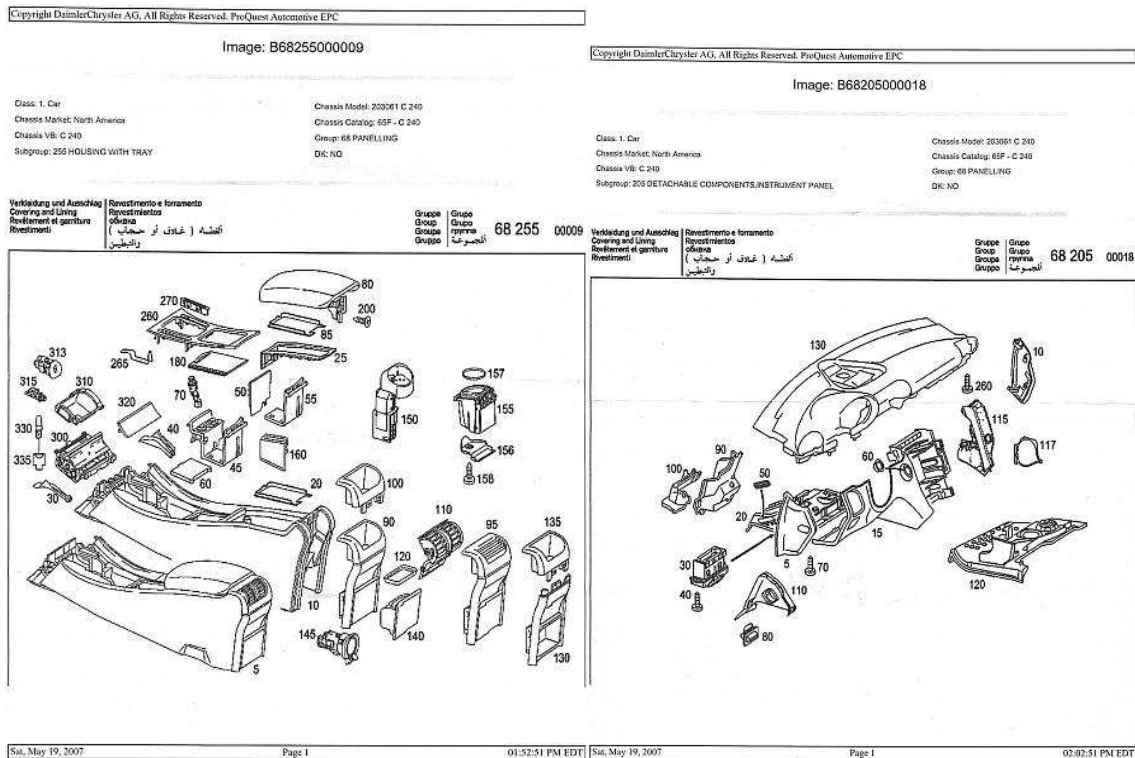

## C240 & G500 Flap Actuator Motor Location

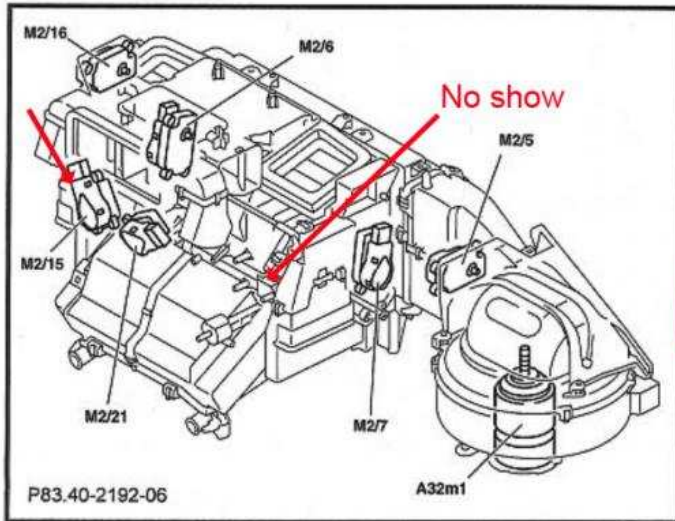

M2/5 - Fresh air / recirculating air flap positioning motor

M2/6 - Left blend air flap positioning motor

M2/7 - Right blend air flap positioning motor

**M2/15 - Left and right footwell flaps positioning motor**

M2/16 - Left and right defroster flaps positioning motor

M2/21 - Fresh air flap positioning motor

## C320 Flap Actuation Motor Location

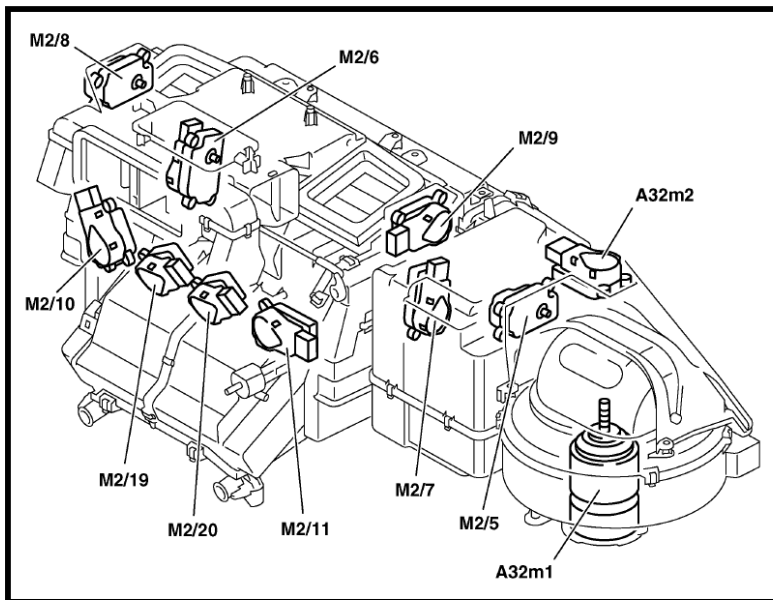

M2/5 - Fresh air / recirculating air flap positioning motor

M2/6 - Left blend air flap positioning motor

M2/7 - Right blend air flap positioning motor

M2/8 - Left defroster flap positioning motor

M2/9 - Right defroster flap positioning motor

M2/10 - Left footwell flap positioning motor

M2/11 - Right footwell flap positioning motor

M2/19 - Left fresh air flap positioning motor

M2/20 - Right fresh air flap positioning motor

A32m1 - Blower motor    A32m2 - Charcoal filter flap motor

Write up courtesy of [Racin\\_fool](#)  
[http://mbworld.org/forums/members/48522-racin\\_fool.html](http://mbworld.org/forums/members/48522-racin_fool.html)

Images courtesy of  
[liveniceguy](#)  
<http://mbworld.org/forums/members/54770-liveniceguy.html>  
[Wilsophia](#)  
<http://mbworld.org/forums/members/215496-wilsophia.html>

M2/19 information courtesy [WaveyKat](#)  
<http://mbworld.org/forums/members/19476-waveykat.html>

Upper Dash Removal courtesy of [noreaga0221](#)  
<http://mbworld.org/forums/members/40139-noreaga0221.html>

Other additions courtesy of  
[vert](#)  
<http://mbworld.org/forums/members/175496-vert.html>  
[strder007](#)  
<http://mbworld.org/forums/members/149731-strder007.html>  
[y2k2c200](#)  
<http://mbworld.org/forums/members/239153-y2k2c200.html>  
[ferdiyan](#)  
<http://mbworld.org/forums/members/231971-ferdiyan.html>

Part numbers courtesy of me [krazzdav](#)  
<http://mbworld.org/forums/members/206007-krazzdav.html>

Item	30	A2038300233 Operating Lever Right
Item	20	A2038300133 Operating Lever Left
Item	115	A2038300033 Operating Parts Kit
Item	110	A2038300032 Linkage – Parts Kit, Footwell flaps without operating lever
Item	310	A2038201642 Stepper Motor / flap positioning motor (all same)
Item	320	A2308216351 Blower Regulator
Item	330	A2038202514 Electric Motor

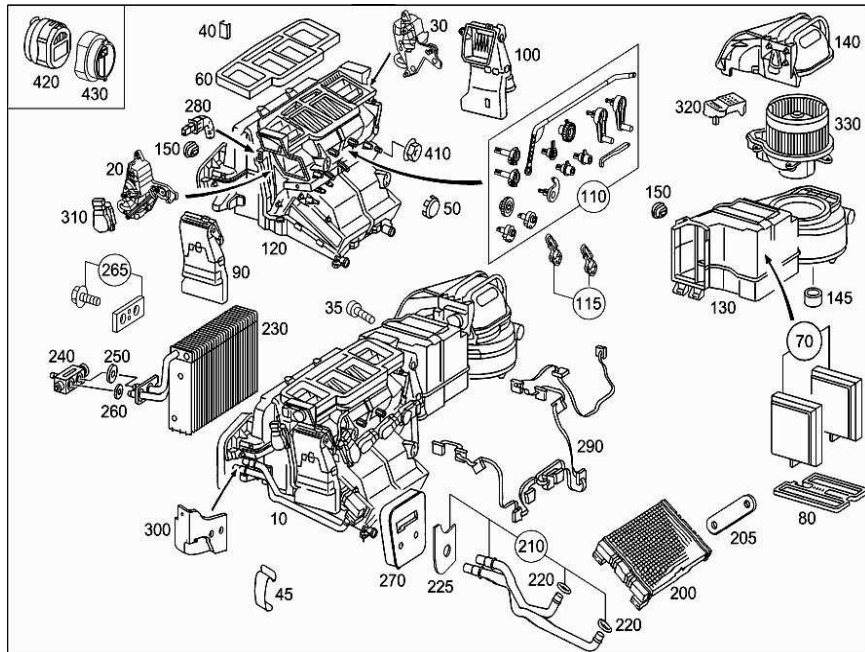

**FUJIFILM**  
Mercedes-Benz  
Mid AC and Audio panel

**FUJIFILM**  
Mercedes-Benz  
Steer and lighting control panel



**FUJIFILM**  
Mercedes-Benz  
Shift knob panel

Rear AC blower fan

Item needed:

(1) Footwell flap linkage kit with 2 linkage arms (will edit with the part# tomorrow)

\*Note - 99% of the time you do NOT need the A/c stepper motor\*

Tools you will need:

(1) flashlight of some kind

(1) 10mm socket (6 or 12pt)

(1) 3/8" ratchet

(1) 6-12" 3/8" extension

(1) T35 Torx socket (3/8")

(1) T20 torx screwdriver

(1) plastic wedge

(1) flat tip small pocket screwdriver (my most used tool)

1. Get in the driver's seat and turn off the car and the radio. I usually listen to the radio for a few minutes before removing it during the process.

2. Pop open the ashtray lid and empty the ashtray.

3. Use either the plastic wedge or your fingers to grab ahold of the front of the shifter surround trim and gently pull it up. Unplug the connectors from it and remove the shifter knob with it. (set all of this in the passenger seat so you won't misplace anything).





4. With the ashtray open, grab a hold of the front of the other trim piece around the shifter that goes from the ashtray to the cupholder. Pop this trim piece off and set it aside.



5. Next open the cupholder area and reach down inside it with either the small screwdriver or some small but long hook and remove the rubber insert where you would set a second cup/drink. (Most people seem to use this as a trashcan or coin holder). The

easiest way is to pry it loose at the rear and reach down inside with your fingers and just pull the insert out.



6. There is a small tab on the cupholder that you need to pull slightly up on to pop it loose and then it just twists out and can be removed and set aside. After this, you will notice 2 small tabs at the front of this section that can be pried loose and you can fold the front half of the cupholder section back exposing (2) of the (4) 10mm screws/bolts you must remove.



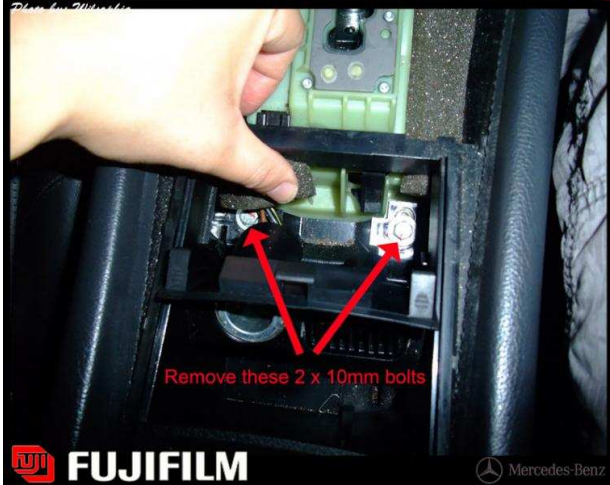

7. Open the center console lower area and empty it. Next, remove the lower cloth section mat at the bottom of this area and it will expose the remaining (2) 10mm bolts you must remove.



\*\*\*\*\*Notice: if you have the rear A/C option, you will need to remove the covers for it and then unscrew the rear a/c blower using the T20 torx screwdriver. Next unplug it and set it aside and then remove the (2) exposed black 10mm bolts.  
(it is inside the center console; there are two small slots on the left and right front side of the top cover where a small flat screw driver was stuck in to release the latch)

Page 8 of 27

Compiled by krazzdav Initial write up by Racin\_fool  
Pics from liveniceguy and Wilsophia  
<http://mbworld.org/>





Photo by: Wilsophia



Photo by: Wilsophia

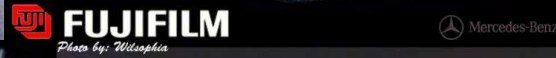

Photo by: Wilsophia

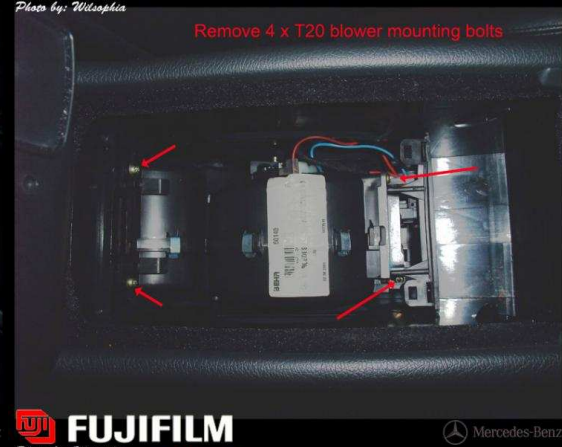

Photo by: Wilsophia

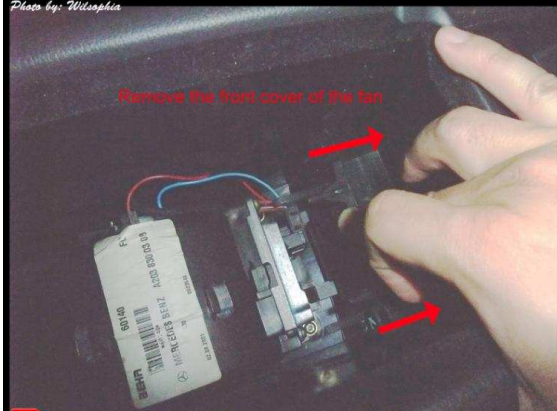

Photo by: Wilsophia

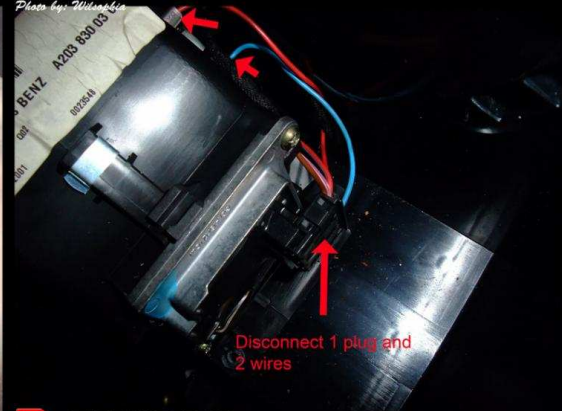
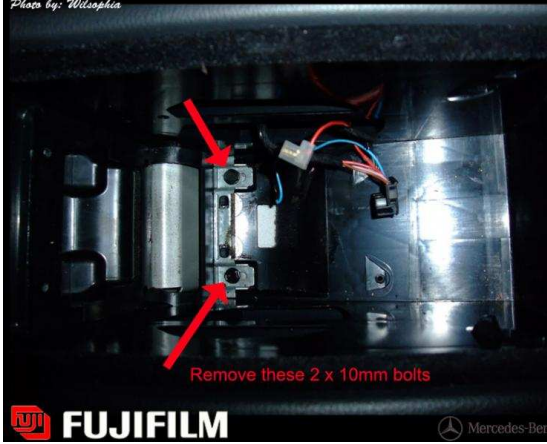
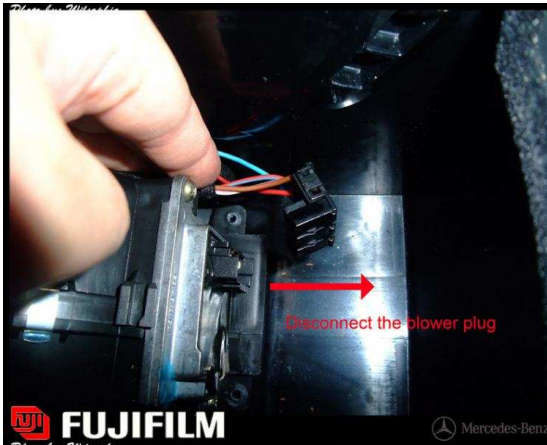

Photo by: Wilsophia





8. \*\*\*\*Notice - engage the parking brake for you and your vehicles safety. Now you should see the black tab at the right rear of the shifter base. Press it forward and pull the gear selector back into neutral or drive. If you have not engaged the parking brake, do so NOW. Grab the small flat tip screwdriver and gently pry the two exposed tabs on the ashtray and pull the assembly up and out of the way. Also, don't forget to unplug it and then set it aside.



