

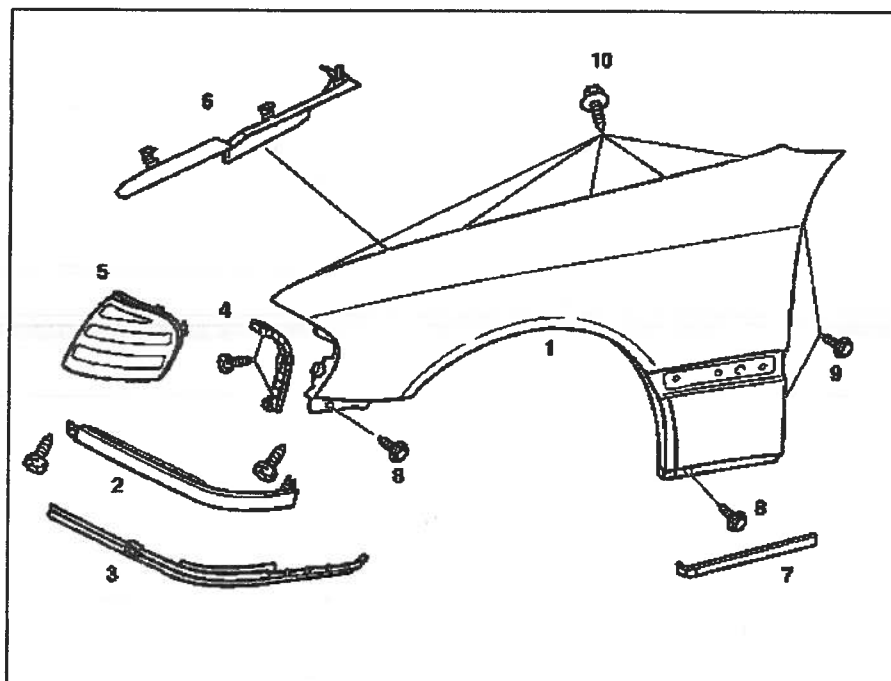



MODEL 202.028 /033 /093

- 1 Fender
- 2 Molding
- 3 Seal
- 4 Bracket
- 5 Turn signal lamp
- 6 Cover
- 7 Cover
- 8 Screws
- 9 Screws
- 10 Screws



P88.10-0001-06

	Removal, installation		
1	Open engine hood and move to upright position		AR88.40-P-1000E
2	Remove front bumper		AR88.20-P-2000E
3	Remove turn signal lamp		
4	Remove molding (2) with seal (3)		
5	Remove cover (6)		
6	Press off cover (7)		*110589035900
7	Unscrew screws (8)		
8	Unscrew screws (9), after opening front door		
9	Unscrew screws (10)		
10	Remove fender (1) upward	When the front fender is replaced install turn signal lamp bracket (4) on new fender	
11.1	Bend over edge on fender	Models 202.028/033/093 C 36 and C 43 AMG and vehicles with 7.5 Jx17 H2 ET 35 AMG wheels	AR88.10-P-1000-01B
12	Apply permanent MB underbody protection agent to replacement fender		
13	Reinstall in opposite order	 When installing ensure that fender is positioned correctly in relation to front door and engine hood, the inner fender seal must make contact	
14	Preserve hollow cavities		

- 1 Bend over edge of fender in area indicated (A) to 100° (original 50°).

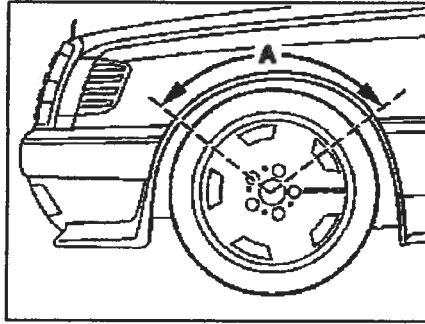

P88.10-0286-01

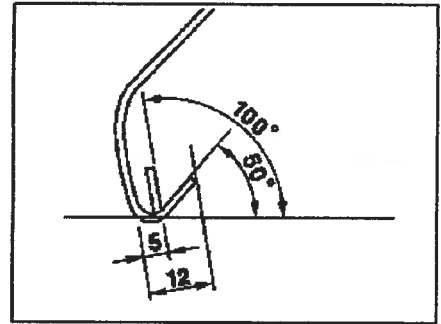

P88.10-0287-01