



SHOPPING CART



Michelin - X-ice Xi3 - 245/40R18 97H XL
SKU: MI24422 

x CA\$268.66

CA\$537.32



Michelin - X-ice Xi3 - 225/45R18 95H XL
SKU: MI41826A 

x CA\$224.99

CA\$449.98



Replika Wheels R157 Gloss Black/Noir lustré , 18X8.0, 5x112, (offset/déport 32) 66.5 Mercedes
SKU: R157-1880-44BN+32R665&&kit-sansano&&boltnoir&&pose-gratuit&&tpms 

x CA\$235.70

CA\$471.40

Installation Kit for Wheels / Mags (per wheel):
2 x Mags Installation Kit - CA\$24.98

Options - Centering Rings (per wheel):
2 x Without centering rings [Reduction] - -CA\$5.00

Options - Nuts / Bolts (per wheel):
2 x Black-Painted Bolts - European Vehicle - CA\$19.98

What are you buying today?:
2 x Wheels AND tires package

Get your package ready-to-install:
2 x Free - When purchasing a package worth over \$800 before taxes

Valves (per wheel):
2 x TPMS valves programmed for your vehicle - CA\$103.98

Inflating (per tire-wheel kit):
2 x Air Inflation

[Edit](#)



Replika Wheels R157 Black wheel | 18X8.5, 5x112, 66.5, 45 offset
 SKU: R157-1885-44BN+45R664&&kit-sansano&&boltnoir&&tpms&&pose-gratuit



2 x CA\$235.70

Installation Kit for Wheels / Mags (per wheel):

2 x Mags Installation Kit - CA\$24.98

Options - Centering Rings (per wheel):

2 x Without centering rings [Reduction] - -CA\$5.00

Options - Nuts / Bolts (per wheel):

2 x Black-Painted Bolts - European Vehicle - CA\$19.98

What are you buying today?:

2 x Wheels AND tires package

Valves (per wheel):

2 x TPMS valves programmed for your vehicle - CA\$103.98

Get your package ready-to-install:

2 x Free - When purchasing a package worth over \$800 before taxes

Inflating (per tire-wheel kit):

2 x Air Inflation

[Edit](#)

CA\$471.40

FREE SHIPPING ON EVERY SET OF 4 TIRES AND/OR 4 WHEELS AND MORE!*

[Continue Shopping](#)

[Clear Shopping Cart](#)

[Update Shopping Cart](#)

Estimate Shipping and Tax

Enter your destination to get a shipping estimate. (See our Shipping Policy)

* Country: * State/Province: * Zip:

[Estimate](#)

FedEx

Ground | CA\$0.00 | Arrives by 9/25/2017

[Update Total](#)

Apply Coupon Code

Subtotal	CA\$1,930.10
Shipping & Handling (FedEx - Ground)	CA\$0.00
Grand Total Excl. Tax	CA\$1,930.10
Tax	CA\$96.51
Grand Total Incl. Tax	CA\$2,026.61

[Proceed to Checkout](#)

30-Day Satisfaction Guaranteed!



[ABOUT](#)

[ALLOY WHEELS](#)

[CATALOG](#)

[FIND A DEALER](#)

[GALLERY](#)

[SEARCH BY VEHICLE](#)

R157

Mercedes-AMG 2017 C43 4MATIC Sedan (W205)



	Front	Rear
Make:	Mercedes	Mercedes
Model #:	R157	R157
Size:	18x8.0	18x8.5
P.C.D.:	5x112mm	5x112mm
Offset:	+32	+45
Finish:	Gloss Black	Gloss Black
Bore:	66.5 mm	66.5 mm
Seat:	R13 Radius	R13 Radius
Lip Size:	N/A	N/A
Weight:	25.4 lbs	26.6 lbs
Load Rating:	1808 lbs / 820 kg	1808 lbs / 820 kg
Winter Approved:	Yes	Yes
Finish:		

Suggested Retail: **\$224.99** **\$224.99**

Dealer may sell for less.



ADD TO FAVORITES

FIND A DEALER





Replika R157 Black

From: <https://tiresize.com/comparison/>

Tire Size Comparison Calculator

Size 1 / R

Size 2 / R

[Compare](#)

	Size 1	Size 2	
Diameter	26"	26.1"	+0.4%
Width	8.9"	8.9"	0%
Sidewall	4"	3.5"	-12.5%
Circum.	81.6"	81.9"	+0.4%
Revs/Mile	800	797	-3

Tire Size Comparison Visualizer [Show Alternate Sizes \[+\]](#)

[Looking to Compare Wheel Offset?](#)

Speedometer Error
(Set Size1 to OEM Size)

Speed	20 mph	30 mph	40 mph	50 mph	60 mph	70 mph	80 mph	90 mph
Actual	20.1	30.1	40.2	50.2	60.2	70.3	80.3	90.3

Tire Brands

[BFGoodrich](#)

Tire Size Tools

[Tire Size Converter](#)

Tire Size Comparison Calculator

Size 1 / R
 Size 2 / R

Compare

	Size 1	Size 2	
Diameter	25.7"	26"	+1.2%
Width	9.6"	10"	+4.2%
Sidewall	3.9"	3.5"	-10.3%
Circum.	80.7"	81.7"	+1.2%
Revs/Mile	808	799	-9

Tire Brands

BFGoodrich

Tire Size Tools

Tire Size Converter

Tire Size Comparison Visualizer

Show Alternate Sizes [+]

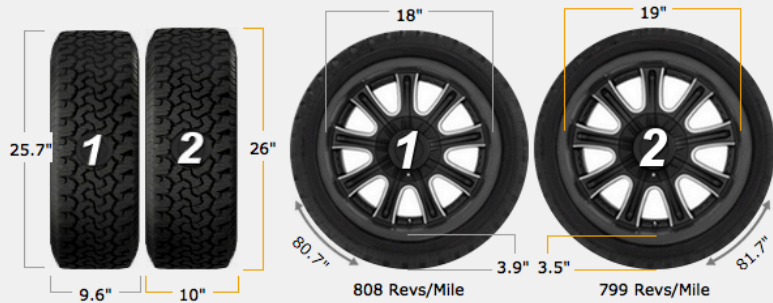

[Looking to Compare Wheel Offset?](#)

Speedometer Error

(Set Size1 to OEM Size)

Speed	20 mph	30 mph	40 mph	50 mph	60 mph	70 mph	80 mph	90 mph
Actual	20.2	30.4	40.5	50.6	60.7	70.8	80.9	91.1

Front wheels: AMG 19" vs purchased 18"

Current Wheel Specs

Width

inches

Offset

mm



New Wheel Specs

Width

inches

Offset

mm



 **CALCULATE**

Results

Inner Clearance:

(the inside of the wheel
to the strut housing)

Outer Position:

(position of the outside
edge of the wheel)

Rear wheels: AMG 19" vs purchased 18"

Current Wheel Specs

Width

8.5

inches

Offset

52

mm



New Wheel Specs

Width

8.5

inches

Offset

45

mm



 **CALCULATE**

Results

Inner Clearance:

7mm MORE

(the inside of the wheel
to the strut housing)

Outer Position:

EXTEND an extra 7mm

(position of the outside
edge of the wheel)

TyreSize4RimSize Calculator

SELECT RIM SIZE

e.g. 6.5" x 15"

X

Find Tyre Size

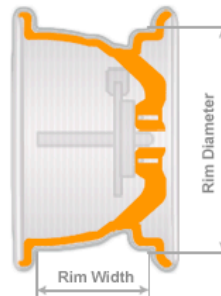

TyreSizeCalculator.com

Tyre widths you can fit to the rim width: 8"	
Minimum tyre width	215
Ideal tyre width	225, 235
Maximum tyre width	245

Tyres with minimum tyre width for wheel: 8x18
215/35R18
215/40R18
215/45R18
215/50R18
215/55R18

Tyres with ideal tyre width for wheel: 8x18
225/30R18
225/35R18
225/40R18
225/45R18
225/50R18
225/55R18
225/60R18
225/65R18
235/30R18
235/35R18
235/40R18
235/45R18
235/50R18
235/55R18
235/60R18
235/65R18

Tyres with maximum tyre width for wheel: 8x18
245/30R18
245/35R18
245/40R18
245/45R18
245/50R18
245/55R18
245/60R18
245/65R18

TyreSize4RimSize Calculator

SELECT RIM SIZE
e.g. 6.5" x 15"

8.5 X 18

Find Tyre Size

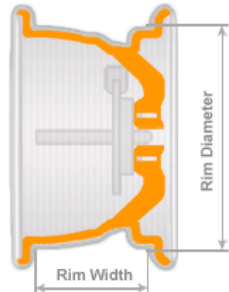

TyreSizeCalculator.com

Tyre widths you can fit to the rim width: 8.5"	
Minimum tyre width	225
Ideal tyre width	235, 245
Maximum tyre width	255

Tyres with minimum tyre width for wheel: 8.5x18
225/30R18
225/35R18
225/40R18
225/45R18
225/50R18
225/55R18
225/60R18
225/65R18

Tyres with ideal tyre width for wheel: 8.5x18
235/30R18
235/35R18
235/40R18
235/45R18
235/50R18
235/55R18
235/60R18
235/65R18
245/30R18
245/35R18
245/40R18
245/45R18
245/50R18
245/55R18
245/60R18
245/65R18

Tyres with maximum tyre width for wheel: 8.5x18
255/30R18
255/35R18
255/40R18
255/45R18
255/50R18
255/55R18
255/60R18
255/65R18
255/70R18

X-Ice Xi3 tire sizes

225/40R18/XL 92H
235/40R18/XL 95H
245/40R18/XL 97H
215/45R18/XL 93H
225/45R18/XL 95H
235/45R18/XL 98H
245/45R18/XL 100H
255/45R18/XL 103H
225/50R18/XL 99H
235/50R18/XL 101H
245/50R18/XL 104H
215/55R18/XL 99H
225/55R18 98H
225/60R18 100H
245/40R19/XL 98H
245/45R19/XL 102H

From: <http://www.fr.michelin.ca/CA/en/tires/products/x-ice-xi3.html>

Since the wheels are all-black, the C43's centre-caps are silver (and the fitment was "unknown"), I ordered some black-motif centre-caps for the wheels also -- it added \$120 CAD to the order total. Interestingly, the delivered caps were actually Mercedes parts.



From apa.ca:

Bridgestone



Blizzak WS 80

Price: \$197

Bridgestone introduced the Blizzak line in the 1990s, the first tire to feature a special rubber compound that dramatically improved performance on ice. The WS 80 is the sixth generation of the Blizzak concept. Directional tire, optimized for snow and ice; compared to the WS 70 which this tire supercedes, the tread is a bit shallower and less aggressive, and provides improved braking on ice and better dry road performance. The WS 80 likely still offers better traction in slush than the Michelin X-Ice. Soft riding. Very good overall performance and predictability; a very good choice for severe conditions. Bridgestone reduced prices in Canada last year, and they are now slightly lower than Michelin. [Mail-in rebate when you buy four tires.](#)

From apa.ca:

Michelin

X-Ice Xi3

Price: \$215



Among Consumer Reports' preferred tires in testing because of its superior performance on wet and dry roads, and ride comfort. Optimized for ice and snow, this tire was among the favorites with tire dealers surveyed. Some consumers using the previous version of this tire reported that traction in slush was unimpressive, and that the shallow, conservative tread limits its traction in deep snow. Best-in-class performance on pavement. Quiet. Long wearing. Tricky mileage warranty requires the tires to be virtual banana peels before you can collect. [Mail-in rebate when you buy four tires.](#)

From Car and Driver magazine's testing:





Test Results

	SNOWCROSS LAP TIME, SEC	SNOW ACCELERATION, 3-18 MPH, SEC	SNOW BRAKING, 18-3 MPH, FT	ICE ACCELERATION, 3-16 MPH, SEC	ICE BRAKING, 16-3 MPH, FT
Bridgestone	30.15	3.48	33.3	7.34	37.8
Continental	29.52	3.46	34.5	7.28	38.2
Dunlop	29.74	3.55	33.8	8.31	39.1
Michelin	29.73	3.41	33.5	7.19	36.3
Nokian	29.43	3.40	33.3	7.02	36.0
Yokohama	31.17	3.53	34.7	8.00	38.9

Final Results

	SNOW- CROSS LAP TIME	SNOW ACCELER- ATION	SNOW BRAKING	ICE ACCELER- ATION	ICE BRAKING	PRICE	SUBJEC- TIVE RATING	GRAND TOTAL
Max Pts. Available	40	20	20	20	20	10	20	150
1. Nokian	40	20	20	20	20	4	20	144
2. Michelin	38	20	20	19	20	8	18	143
3. Continental	39	19	18	18	17	10	17	138
4. Bridgestone	36	18	20	18	17	7	14	130
5. Dunlop	38	17	19	12	16	9	16	127
6. Yokohama	30	17	18	14	16	10	14	119

On ice in hockey rink:

TIRE	ACCELERATION W/TCS 60' (SECONDS)	BRAKING W/ABS 12-0 MPH (FEET)
 BRIDGESTONE Blizzak WS80	4.55	30.90
 DUNLOP Tires Winter Maxx	4.68	35.40
 MICHELIN X-Ice Xi3	4.64	30.30
 YOKOHAMA iceGUARD iG52c	4.73	33.60

On ice in hockey rink:

TIRE	ACCELERATION W/TCS 0-12 MPH (FEET)	BRAKING W/ABS 20-0 MPH (FEET)
 Blizzak WS80	32.54	66.91
 Winter Maxx	33.14	70.29
 X-Ice Xi3	32.88	66.75
 iceGUARD iG52c	34.34	68.06

TIRE		DRY STOPPING DISTANCE 50-0 MPH (FEET)	WET STOPPING DISTANCE 50-0 MPH (FEET)
 BRIDGESTONE	Blizzak WS80	88.20	128.00
 DUNLOP TIRES	Winter Maxx	97.60	159.40
 MICHELIN	X-Ice Xi3	93.20	131.40
 YOKOHAMA	iceGUARD iG52c	94.70	148.80

Cornering performance had same rankings.

Blizzak: 2nd in handling, 1st in ride quality

X-Ice: 1st in handling, 2nd in ride quality

RATINGS & REVIEWS

BRIDGESTONE BLIZZAK WS80

CONSUMER SURVEYS

Based on 300 submissions of our online survey.

Average Rating: ★★★★★

Performance Category: Studless Ice & Snow

[Compare Ratings for All Tires in This Category](#)

Survey Stats

1,693,077 Total Miles Reported

1 out of 9 in Studless Ice & Snow Tires

100% vs. best in Studless Ice & Snow Tires

Would You Recommend?

9.2 - Excellent

+ Wet Performance

9.2 - Excellent

+ Dry Performance

8.5 - Good

+ Winter/Snow Performance

9.4 - Excellent

+ Comfort Performance

8.6 - Excellent

Treadwear Performance

8.3 - Good

Note: Consumer Survey Ratings are from 0-10 with 10 being the highest.

RATINGS & REVIEWS

MICHELIN X-ICE XI3

CONSUMER SURVEYS

Based on 477 submissions of our online survey.

Average Rating: ★★★★★

Performance Category: Studless Ice & Snow

[Compare Ratings for All Tires in This Category](#)

Survey Stats	
3,015,585	Total Miles Reported
2 out of 9	in Studless Ice & Snow Tires
98%	vs. best in Studless Ice & Snow Tires
Would You Recommend?	8.5 - Good
+ Wet Performance	8.8 - Excellent
+ Dry Performance	8.4 - Good
+ Winter/Snow Performance	8.8 - Excellent
+ Comfort Performance	8.9 - Excellent
Treadwear Performance	9.0 - Excellent

Note: Consumer Survey Ratings are from 0-10 with 10 being the highest.