

## A REVOLUTION IN SIMPLIFIED ADJUSTMENT

INNER BUSH ROTATES INSIDE (stationary) OUTER SLEEVE. Means unlike other brands mount can be inserted in any position! (not just one offset position of adjustment) allowing therefore precise change of adjustment. SIMPLY BY ROTATING BOLT HEADS.

**K-MAC UNIQUE PATENTED INTERLOCKING BOLT / BUSH DESIGN**

**Mono Ball** • 2 Axis & Twice the load bearing area  
• Improved Brake & Steering Response

SHOWING LOWER FRONT CONTROL ARM  
INNER BUSH - AT MAX. OFFSET  
ADJUSTMENT (MINIMUM NEG. CAMBER).

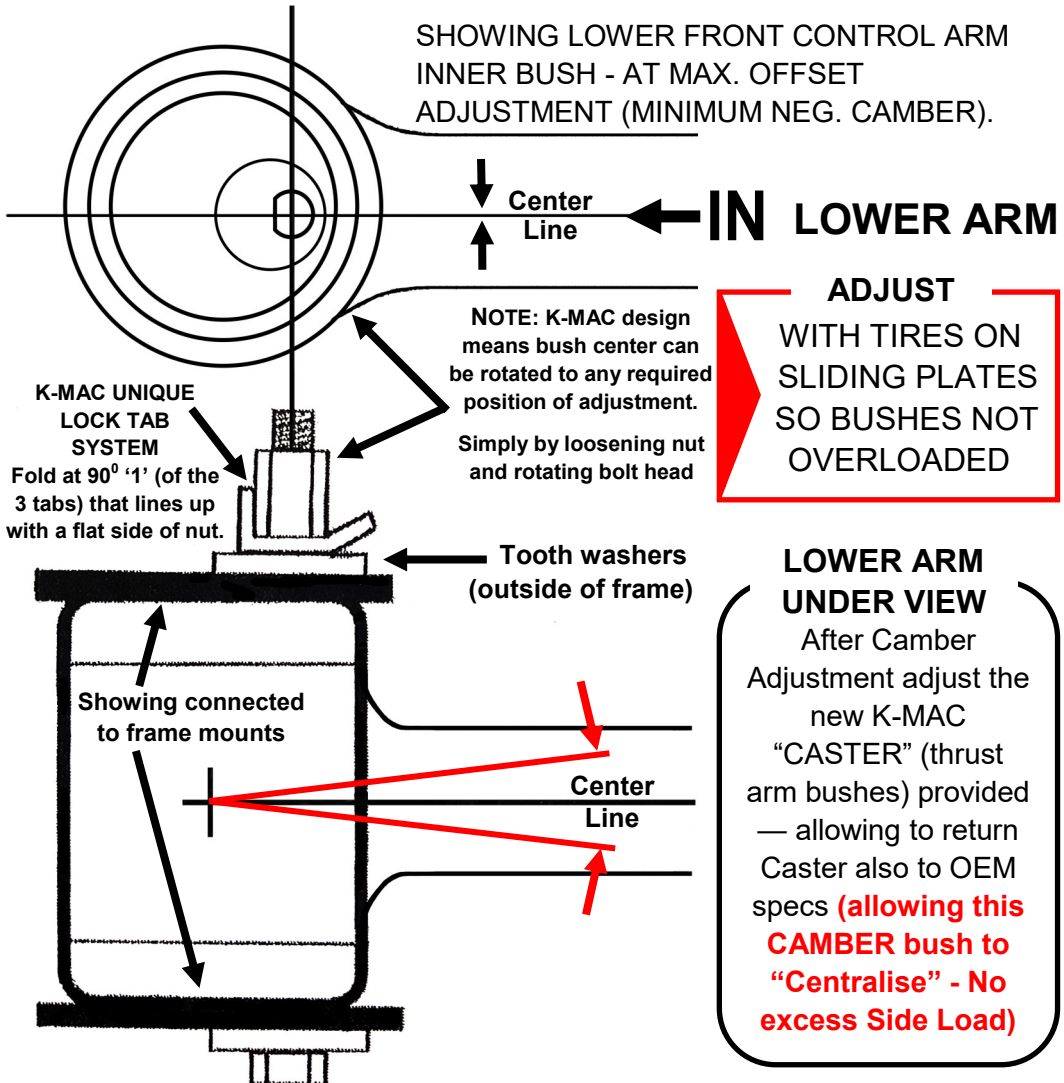

### ADJUST

WITH TIRES ON  
SLIDING PLATES  
SO BUSHES NOT  
OVERLOADED

### LOWER ARM UNDER VIEW

After Camber Adjustment adjust the new K-MAC "CASTER" (thrust arm bushes) provided — allowing to return Caster also to OEM specs (**allowing this CAMBER bush to "Centralise" - No excess Side Load**)