

- Parts list -

<b>Vehicle</b>	WDDGF7HB6CA682592 (62P)	C 63 AMG Sedan	
<b>Color</b>	197 - OBSIDIAN BLACK - METALLIC PAINT	<b>Equipment</b>	221 - LEATHER - BLACK/ANTHRACITE
FIN: WDD2040771A682592		<b>Assortment class</b>	PC
<b>Group</b>	42 Brake system	<b>Sub-group</b>	030 Front wheel brake

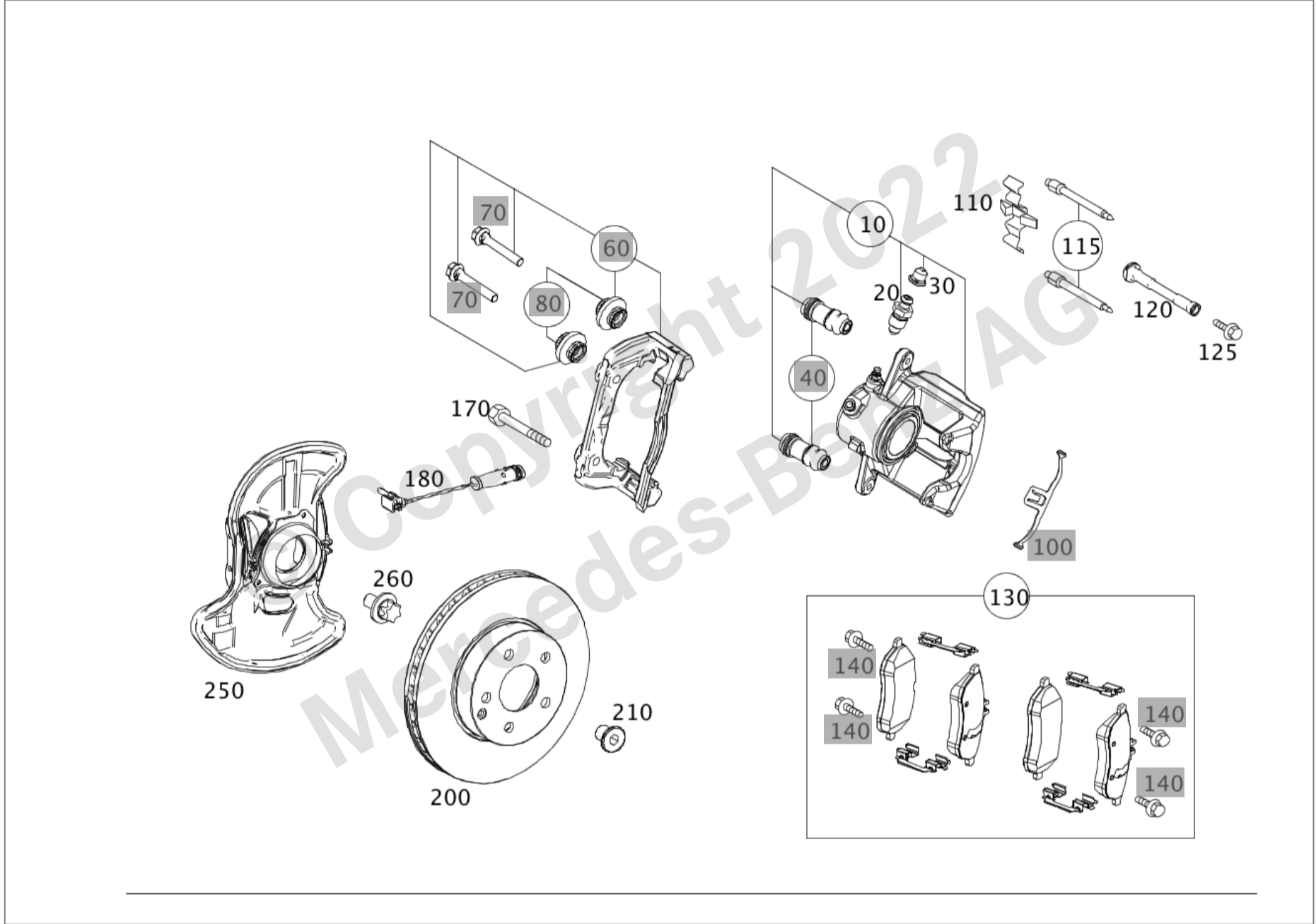



















Image ID: drawing\_B42030000128

Item	Part number	Designation/additional information	Qty
10	A 204 421 21 11	FIXED CALIPER PARTS SET, LEFT [697] PART IS ONLY OR ALSO SUPPLIED AS RECONDITIONED PART Code: M156+M63+(P30/P61)+U70;	1
10	A 204 421 20 11	FIXED CALIPER PARTS SET, RIGHT [697] PART IS ONLY OR ALSO SUPPLIED AS RECONDITIONED PART Code: M156+M63+(P30/P61)+U70;	1
20	A 000 421 47 65	* PARTS KIT, BLEED VALVE WITH DUST CAP Code: M156+M63+(P30/P61)+U70;	2
30	A 000 421 30 48	* DUST CAP Breather valve Code: M156+M63+(P30/P61)+U70; Replaced by: A 000 421 47 65	4
110	A 001 421 09 91	* SPREADER SPRING Code: M156+M63+(P30/P61)+U70;	2

## Parts Information

Item	Part number	Designation/additional information	Qty
115	A 000 421 51 74 	* PARTS KIT, GUIDE PIN Parts kit  Code: M156+M63+(P30/P61)+U70;	2
120	A 221 421 00 14 	* PULL ROD  Code: M156+M63+(P30/P61)+U70;	2
125	A 016 990 06 01 	* COMBI-HEXAGON HEAD BOLT  Code: M156+M63+(P30/P61)+U70;	2
130	A 005 420 89 20	PARTS KIT, BRAKEPAD Parts kit  [431] WHEN SELLING BRAKE LININGS TO END USERS/DESK BUYERS THE A 203 005 25 99 IS TO BE HANDED OVER FREE OF CHARGE  Code: M156+M63+(P30/P61)+U70; Replaced by: A 007 420 65 20 Replaced by: A 000 420 27 04	1
130	A 007 420 65 20	PARTS KIT, BRAKEPAD Parts kit  [431] WHEN SELLING BRAKE LININGS TO END USERS/DESK BUYERS THE A 203 005 25 99 IS TO BE HANDED OVER FREE OF CHARGE  Code: M156+M63+(P30/P61)+U70; Replaced by: A 000 420 27 04 Replaces: A 005 420 89 20	1
170	A 001 990 08 14	HEXAGON FIT BOLT Brake caliper to steering knuckle; M14X32  [408] ONLY REPLACEABLE BY PAIRS  Code: M156+M63;	4
180	A 171 540 06 17	BRAKEPAD WEAR SENSOR BRAKE LINING WEAR INDICATOR  Code: M156+M63;	1
200	A 212 421 05 12	COMPOUND BRAKE DISK Front left  Code: M156+M63+(P30/P61);	1
200	A 212 421 05 12	COMPOUND BRAKE DISK Front right  Code: M156+M63+(P30/P61);	1
210	A 220 421 01 71	FIT SCREW BRAKE DISC TO WHEEL HUB; M8X12	2
250	A 204 421 13 20	PROTECTIVE METAL SHEET LEFT  Code: M156+M63;	1
250	A 204 421 14 20	PROTECTIVE METAL SHEET RIGHT  Code: M156+M63;	1
260	A 220 423 00 71	SCREW PROTECTIVE PLATE TO STEERING KNUCKLE; M6X12  Code: M156; Replaced by: A 000 421 13 71	6