

Dealer Ordering Guide

**PRELIMINARY.
DOCUMENT SUBJECT TO
CHANGE.**



Mercedes-Benz MY17 C-Class Cabriolet C300, C300 4MATIC (A205)

An important note about this Guide:

The information presented in this guide is based on the most current information available and is intended for internal use only. Mercedes-Benz, USA reserves the right to make changes at any time, without notice, to colors, materials, equipment, special specifications and models.

Pricing may not yet be finalized for some models or options.

Due to variances among monitors and printers, the colors that appear on your screen and printouts may not be exact.

For illustrative purposes, some images may show vehicles with European Specifications.

Revision History

Date	Edited By	Changes
4/19/16	K. Edwards	Initial publication. Ordering Banks not yet open.
5/2/16	K. Edwards	Head-Up Display availability delayed until August production.

Table of Contents *(please click on the link to get to the page)*

- [What's new in MY17](#)
- [Models](#)
- [Standard Equipment](#)
- [Paints](#)
- [Upholsteries](#)
- [Fabric Soft Top](#)
- [Trims](#)
- [Wheels](#)
- [Visual Equipment Differentiation](#)
 - [Headlights](#)
- [Option Packages](#)
- [Stand-Alone Options/Special Orders/Accessories](#)
- [Specifications](#)
- [Product Highlights](#)
- [Gallery](#)

What's new: MY17 Overview

Standard Equipment

- 9G-TRONIC 9-Speed Automatic Transmission
- LED Headlamps & Taillamps
- Blind Spot Assist
- Heated Seats
- Rearview Camera
- Removable Wind Blocker
- 18" wheels with All-Season Extended Mobility tires
- Automatic Seatbelt Presenter
- COLLISION PREVENTION ASSIST PLUS (CPA+)
- PRE-SAFE
- Power Passenger Seat
- KEYLESS START
- Pre-wiring for GARMIN® Map Pilot
- DYNAMIC SELECT
- 5 years of mbrace subscription (including Remote Start)
- KEYLESS-GO
- AIRSCARF

Optional Equipment

- Package strategy includes 3 available Premium Packages
- Driver's Assistance Package, Lighting Package, Multimedia Package and Air Balance Package become part of Premium Package equipment
- Introduction of Natural Grain Brown Ash Wood trim
- Leather Upholstery as a stand-alone option replaces Interior Package

Paints

- Introduction of Brilliant Blue Metallic
- Selenite Grey Metallic replaces Palladium Silver and Steel Grey Metallic

Wheels

- New standard 18" 5-spoke wheel (R32)
- New optional Twin 5-Spoke 19" wheel with High-Performance tires (R17)

What's new: AIRSCARF

Standard on all C-Class Cabriolets



This neck-level heating makes open-top driving a pleasure even at low temperatures. Through adjustable air outlets in the head restraints, warm air is 'wrapped' around the necks of the driver and front passenger like an invisible scarf. The desired temperature can be set in three stages. The cool air flows over fins and is heated by a PTC heating element (PTC: positive temperature coefficient). A blower then ensures the required outflow speed. The outflow speed is automatically adjusted to the travelling speed. AIRSCARF air temperature is set through a 3-stage switch.

What's new: Removable Wind Blocker

Standard on all C-Class Cabriolets



The standard wind blocker reduces drafts and the noise level in the interior for front passengers when driving with the top down by increasing the height of the airflow above the passenger compartment. It is fitted to the body above the rear seats, folds in two and can be retrofitted to the vehicle. When not in use, the draught-stop can be stowed in the supplied protective cover behind the rear seats.

When equipped with Premium 1, 2 or 3 packages, the removable wind blocker is replaced by the AIRCAP system.

What's new: 9-Speed Automatic Transmission

Standard on all C300 Cabriolets

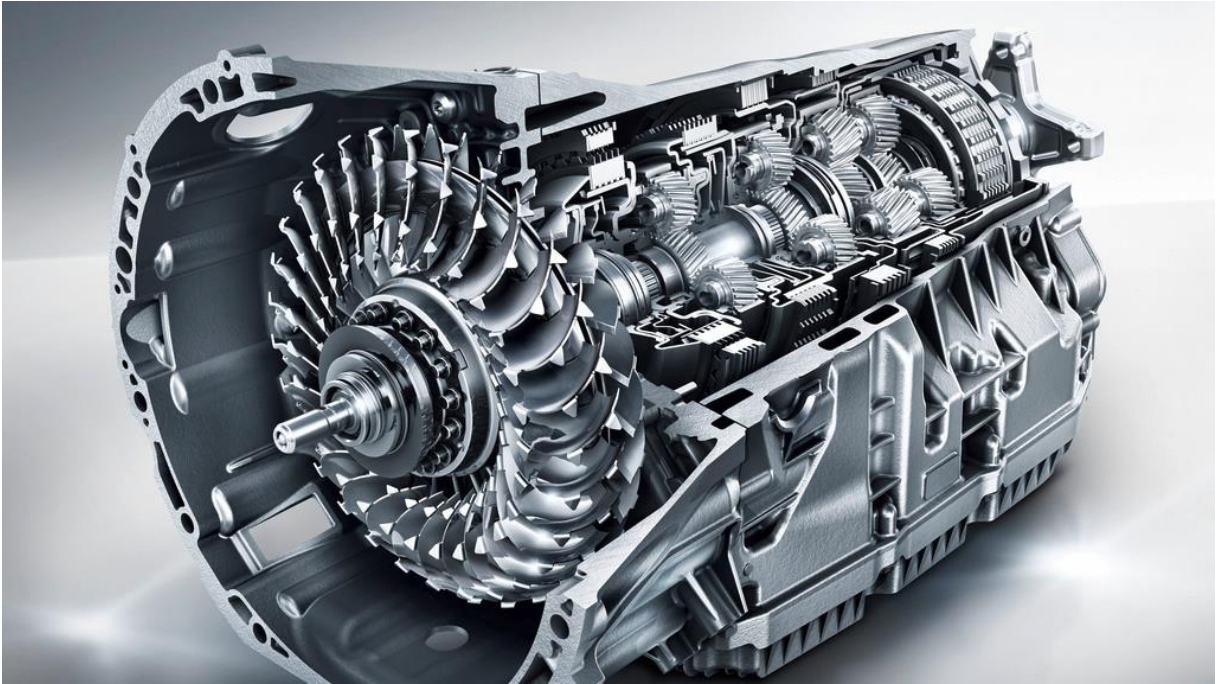

Unique in the C300 family to the C-Class Cabriolet*, gear changing is handled by the 9-Speed Automatic Transmission developed by Mercedes-Benz. It is the world's first 9-Speed automatic transmission in the premium segment that can be used with longitudinally mounted engines. The 9-Speed Automatic Transmission impresses with fast, almost imperceptible gear changes and low noise and vibration levels thanks to lowered engine speed levels.

*C300 Sedan and C300 Coupe (W205 and C205) continue to make use of the 7-Speed Automatic Transmission.

What's new: Rearview Camera

Standard on all C-Class Cabriolets



Reverse parking and maneuvering is made much easier and safer by the reversing camera. It is switched on automatically when the driver selects reverse gear, and shows the driver the area behind the vehicle on the COMAND display. Dynamic guide lines assist the driver with his driving maneuvers. The reversing camera is integrated in the rear trunk lid. It is protected from the elements behind a cover which opens when the camera is activated.

What's new: AIRCAP

Available on all C-Class Cabriolets



When the soft top is down, AIRCAP reduces turbulence in the interior for all passengers. When the AIRCAP switch is pressed, a wind louvre on the windshield pops up and the wind blocker positioned behind the rear head restraints is extended upwards. This enlarges the curvature of the airflow over the passenger compartment. Air turbulence and the noise level can thus be noticeably reduced. The wind blocker is retracted or extended together with the wind louvre via a button on the center console.

AIRCAP is available as a part of Premium 1, 2 and 3 packages.

What's new: Natural Grain Brown Ash Wood Trim

Available on all C-Class Cabriolets



New to the C-Class family, the elegant Natural Grain Brown Ash Wood option follows the success of the popular Natural Grain Black Ash Wood trim with open texture brown wood in the waterfall console and doors.

This combination is not recommended with Cranberry Red Leather.

Models

	Displacement	Power	Torque	MSRP	Launch
C300 (205.448)	2.0-Liter turbo inline-4	241 hp/ 180 kW	273 @ 1,300- 4,000	\$TBD	9/2016
C300 4M (205.449)	2.0-Liter turbo inline-4	241 hp/ 180 kW	273 @ 1,300- 4,000	\$TBD	9/2016



Standard Equipment Highlights

Performance/Handling

- 9-speed automatic transmission with paddle shifters
- Multi-Link Front Suspension
- Multi-Link Independent Rear Suspension
- DYNAMIC SELECT
- Adaptive Braking Technology
- All-Season Tires
- ECO Start/Stop Technology
- 18" Wheels

Comfort/Convenience

- KEYLESS START & KEYLESS-GO
- Audio System with CD drive
- Two USB Ports
- Bluetooth Technology (for Handsfree Phone Use/Audio Streaming)
- HD Radio
- Power Front Seats with Driver Memory
- 4-way Lumbar Support
- Power Tilt & Telescoping Steering Column
- Electronic Cruise Control
- Power Windows with Express Up and Down
- Automatic Headlamps with Twilight Sensor & Locator Lighting
- Split-Folding Rear Seats (50:50)
- Central Controller with 7" high-mounted tablet-style color display
- Multifunction leather steering wheel
- Pre-wiring for GARMIN® Map Pilot
- Dual-zone Automatic Climate Control
- Garage Door Opener
- Intermittent Wipers with Rain Sensor
- Automatic Seatbelt Extender
- Heated Front Seats



Standard Equipment Highlights (continued)

Comfort/Convenience (Continued)

- AIRSCARF
- LED Headlamps and taillights
- Auto-Dimming Driver & Rear View Mirror
- FrontBass® speed-sensitive five speaker sound system
- Front and Rear Cupholders

Safety/Security

- New Vehicle 4 Year/50,000 Mile Warranty
- 24h Roadside Assistance Program
- 3-point Seat Belt with Pretensioners & Dual-Stage Belt Force Limiter
- Front Dual Stage Airbags
- Front and Rear Side Window Airbags
- Front Side Airbags
- Driver & Passenger Kneebags
- ISOFIX Anchor and Tether System
- ATTENTION ASSIST Driver Drowsiness Monitor
- COLLISION PREVENTION ASSIST PLUS (CPA+)
- PRE-SAFE
- Smart Key with Panic Button
- Tire Pressure Monitoring System
- Anti-theft Alarm System
- Blind Spot Assist
- Rearview Camera



Paints

Non-metallic Paints



040
Black



149
Polar White

Metallic Paints*

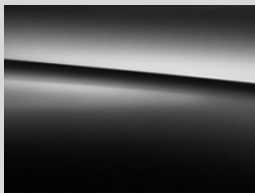

197
Obsidian Black

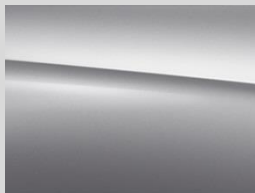

775
Iridium Silver



796
Dakota Brown



890
Lunar Blue



896
Brilliant Blue

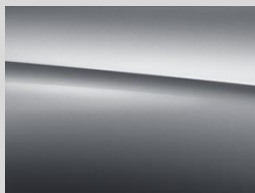

988
Diamond Silver



992
Selenite Grey

designo Metallic Paints



Metallic paint with high-quality effect pigments and exclusive color shades

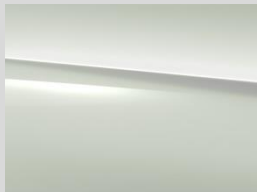

799
Diamond White
\$1,515



996
Cardinal Red
\$1,080



Upholsteries

C300/ C300 4MATIC

MB-**Tex**



101 Black



105 Silk Beige/Black



118 Crystal Grey/Black



124 Saddle Brown/Black

Leather

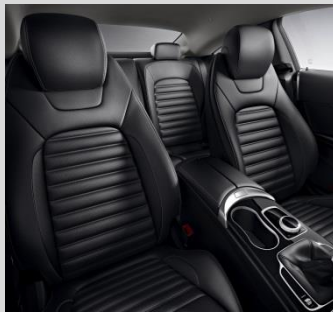

201 Black



218 Crystal Grey/Black



224 Saddle Brown/Black



225 Porcelain / Black



227 Cranberry Red/Black

Fabric Soft Top

740 - Black



- Standard on all models

741 - Dark Brown



- Optional on all models
- No cost

744 - Dark Blue



- Optional on all models
- No cost

746 - Red



- Optional on all models
- No cost

Trims

739 – Aluminum/High-Gloss Black



- Standard on all models

736 – Natural Grain Black Ash Wood*

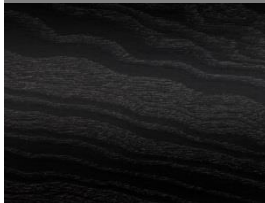

- Requires 321 – Sport Package
- **\$325**

H07– Linden Wood*



- Optional on all models
- **\$325**

H09 – Natural Grain Brown Ash Wood*



- Optional on all models
- **\$325**



Wheels

Standard

N/C Option

Optional

C300/4M



R32 - 5-Spoke Wheel
All-Season
18"



22R - Split 5-Spoke
All-Season
18"



R17 - Twin 5-Spoke
High-Performance
19"

C300/4M
Sport Package



782 - AMG 5-Spoke
All-Season
18"



788 - AMG Multi-Spoke
High-Performance
19"



Visual Equipment Differentiation

Headlights

LED Headlamps (Standard)



- All functions feature LED technology
- Integrated LED daytime running lamps with fibre-optics
- Projector LED low beam and reflective LED high beam technology
- Full LED tail lamps with fibre-optics

Dynamic LED Headlamps (P03 – Premium 3 Package)



- All functions of the Static LED Headlamps plus:
- Active light function for better illumination in curves
 - Dual low/high beam LED projection modules



Option Packages

P01 – Premium 1 Package

\$TBD

Not with (P02) Premium 2 Package or (P03) Premium 3 Package.

- 288 – AIRCAP
- 536 – SiriusXM® Satellite Radio
- 810 – Burmester® Surround Sound System

P02 – Premium 2 Package

\$TBD

Not with (P01) Premium 1 Package or (P03) Premium 3 Package.

Includes all (P01) Premium 1 Package features plus:

- 531 – COMAND Navigation and Voice Control
- 502 – Navigation Map Updates included for 3 years
- 5 years Traffic and Weather Services (provided by SiriusXM®)
- 8.4” High-Resolution Screen
- P17 – Hands-Free Access
- 500 – Power Folding Mirrors
- 877 – Ambient Lighting
- U25 – Illuminated Door Sills
- 881 – Electronic Trunk Closer

P03 – Premium 3 Package

\$TBD

Not with (P01) Premium 1 Package or (P02) Premium 2 Package.

Includes all (P02) Premium 2 Package features plus:

- 233 – DISTRONIC PLUS with Steering Assist
- 237 – Active Blind Spot Assist *replaces (234) Blind Spot Assist*
- 238 – Active Lane Keeping Assist
- 253 – PRE-SAFE Plus
- 513 – Speed Limit Assist
- P21 – AIR BALANCE
- 640 – Active LED Headlamps
- 608 – Adaptive Highbeam Assist

Option Packages (continued)

315 – AIRMATIC Package

\$TBD

- 483 – DYNAMIC SELECT Adjustable Suspension
- 489 – AIRMATIC Air Suspension
replaces (677) Sport Tuned Suspension or (486) Sport Suspension

321 – Sport Package

\$TBD

Requires (486) Sport Suspension or (315) AIRMATIC Package.

- 772 – AMG Bodystyling
- 51U – Black Headliner
- U09 – Dash with MB-Tex and top-stitching
- Wheel choice of:
 - (782) 18” AMG Wheels
 - (788) 19” AMG Wheels
with High Performance Tires (+\$500)
- Diamond Grill in Chrome
- Flat Bottom Sport Steering Wheel
- Front brakes with perforated discs
- Aluminum Pedals with Rubber Studs
- AMG Floor mats

996 – Parking Assist Package

\$TBD

Requires Premium 2 (P02) or Premium 3 (P03) Packages.

- 235 – PARKTRONIC with Active Parking Assist
- 501 – Surround View Camera



Stand-Alone Options/Special Order/Accessories

Stand-Alone Options

XXX	Leather Upholstery (All Colors)	\$TBD
242	Passenger Memory Seat w/ Adjustable Thigh Support	\$TBD
401	Heated and Ventilated Seats <i>Only with Leather Upholstery</i>	\$TBD
463	Head-Up Display <i>Delayed Availability Until August 2016 Production</i>	\$TBD

MB Accessories Program

03A	SD-Card for GARMIN® Map Pilot Navigation	\$625
00A*	Illuminated Star <i>Not available with Premium 3 (P03)</i>	\$550
068	Wheel Locks (Black)	\$150
070	Chrome Door Handle Inserts	\$70



Specifications

	C300	C300 4MATIC
Engine Configuration	2.0L Turbo I4	2.0L Turbo I4
Power (hp) @ 5,550 rpm	241	241
Torque (lb-ft) @ 1,300 - 4,000 rpm	273	273
Acceleration 0-60mph (sec)	6.3	6.3
Fuel Economy (Cty/Hwy/Com)	TBD	TBD
Top Speed (mph)	TBD	TBD
Fuel Requirement (Octane)	91	91
# Valves per cylinder	4	4
Compression	9.8 : 1	9.8 : 1
Transmission	9-Speed Automatic	9-Speed Automatic
Transmission Speeds	9	9
Drive Configuration	Rear-Wheel Drive	All-Wheel Drive
Standard Front Wheel	7.5 J x 18	7.5 J x 18
Standard Rear Wheel	8.5 J x 18	8.5 J x 18
Standard Front Tire Size	225/45 R18	225/45 R18
Standard Rear Tire Size	245/40 R18	245/40 R18
Standard Tire Type	All Season	All Season
Fuel Tank Size (gallons)	17.4	7.4
Trunk Size (cubic feet)	8.8	8.8
Curb Weight (lbs)	3,836	3,957
Vehicle Length (in.)	184.5	184.5
Vehicle Width (in.)	71.3	71.3
Vehicle Height (in.)	55.5	55.5
Wheelbase	111.8	111.8
Track Width Front/Rear (in.)	61.53/60.86	61.61/60.75
Coefficient of Drag (Cd)	0.31	0.31



Specifications*

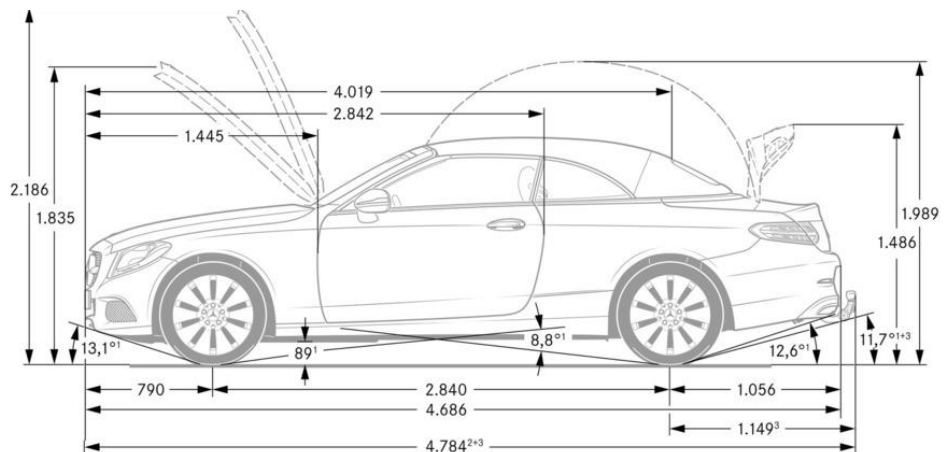
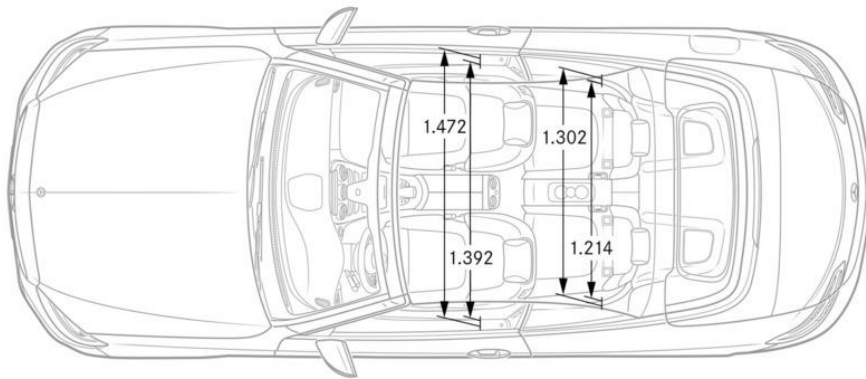
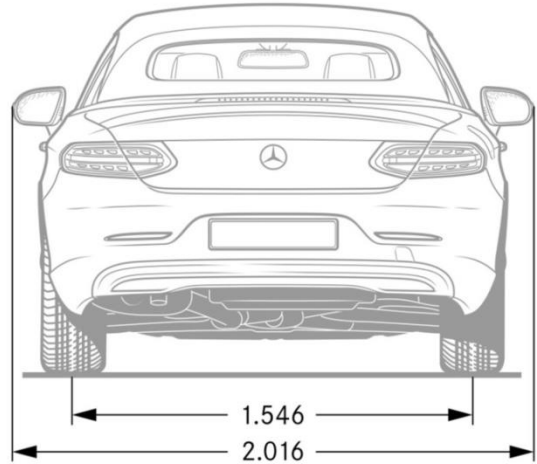
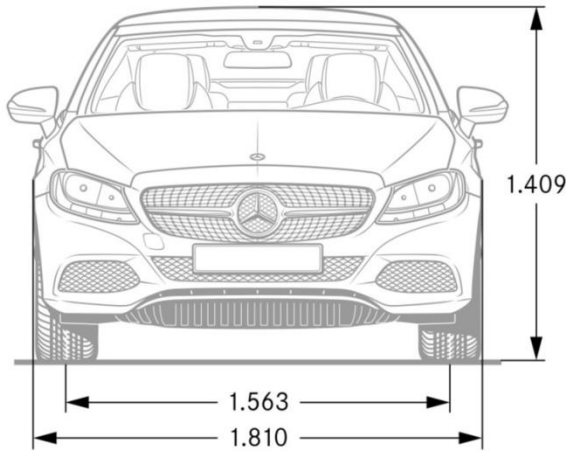

*Values shown in meters

Product Highlights:

COLLISION PREVENTION ASSIST PLUS

Standard on all C-Class Cabriolets

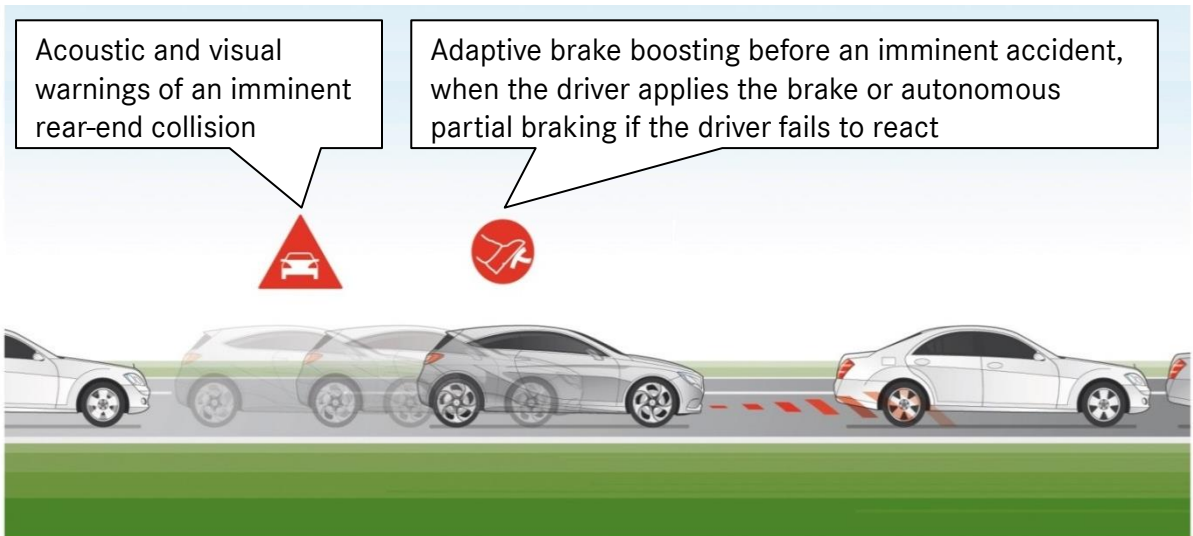

- Driving assistance system to lessen the danger of rear-end collisions and mitigate the consequences of accidents
- Combination of radar-based distance warning, assisted braking by Adaptive Brake Assist and autonomous partial braking
- Visual warning via a warning light in the instrument cluster when the safe distance to vehicles in front is too low within a speed range between 4 and 155 mph
- An additional audible warning is sounded if the distance continues to close rapidly
- In case of emergency braking by the driver – and if necessary – COLLISION PREVENTION ASSIST PLUS will increase the brake pressure provided by Adaptive Brake Assist to prevent a collision
- Initiation of autonomous partial braking if the driver fails to react within a speed range of 4 and 65 mph



Product Highlights: 50/50 Split-Folding Rear Seats

Standard on all C-Class Cabriolets



For added practicality, the rear seats feature a 50/50 split to increase trunk capacity and allow for the storage of long items, even with the soft top retracted..



Product Highlights: AIRMATIC Air Suspension

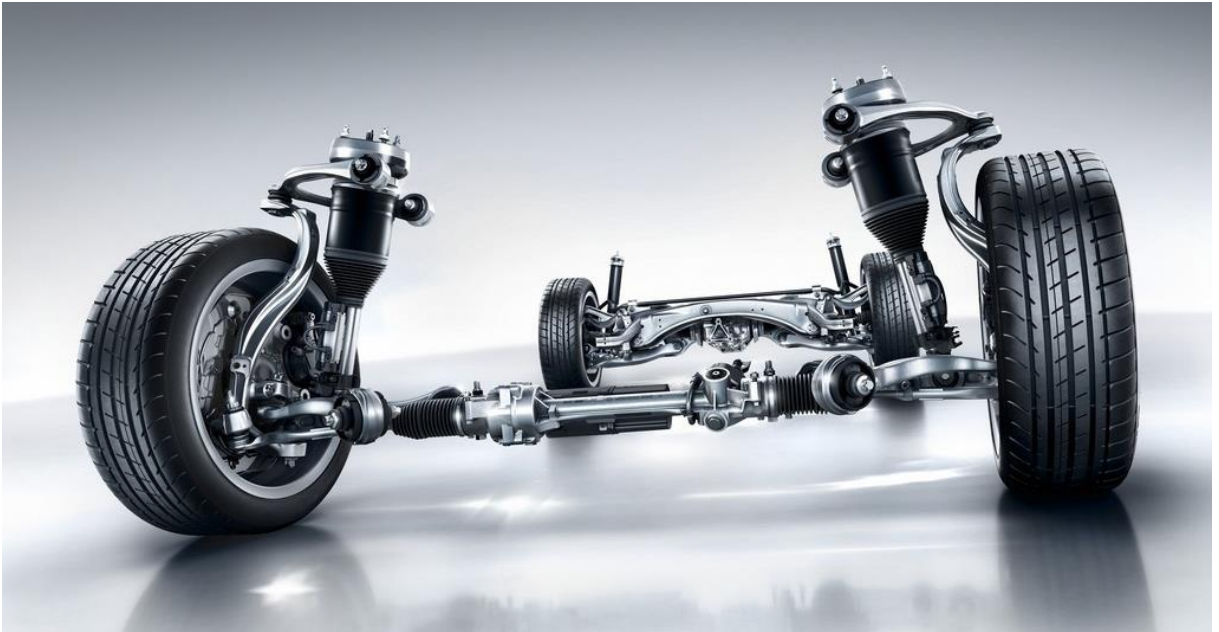

The combination of AIRMATIC air suspension and DYNAMIC SELECT provides for a tailor-made driving experience.

- DYNAMIC air suspension with continuously variable damping control
- DYNAMIC SELECT with four different transmission modes (adjustment of parameters such as engine, transmission, suspension, steering, air conditioning or ECO start/stop function)
- The individual parameters are set via the controller and the configuration menu in the head unit
- Display of the selected transmission mode in the instrument cluster and head unit



Product Highlights: Head-Up Display

Optional for all C-Class Cabriolets



Keeping an eye on key information and the road ahead:

- Key driver information at a glance, without the driver having to take their eyes off the road
- Projection of a virtual image measuring approximately 8.2 x 2.8 inches into the driver's field of vision, which appears to float around 6.5 feet in front of him/her, above the bonnet.
- Information is displayed in high-resolution and in color.
- Depending on equipment, the information displayed may include navigation tips, speed, speed limits or settings for cruise control or DISTRONIC PLUS.
- Special light sensor adjusts the brightness of the display to suit the ambient light conditions.
- Height of the display can be adjusted, making it easy to read for drivers of all sizes.



Product Highlights: Ambient Lighting

Optional for all C-Class Cabriolets



Climb in and feel at home – with its pleasant, indirect light, the ambient lighting creates an unrivalled sense of well-being in the interior. Especially at night, it accentuates the contouring and high quality of the interior design.

Three different colors and five dimming levels are available for the desired lighting mood:

- neutral (white)
- solar (amber)
- polar (ice blue)

