

### Engine compartment prefuse box

F32/3 Engine compartment prefuse box

X Direction of travel

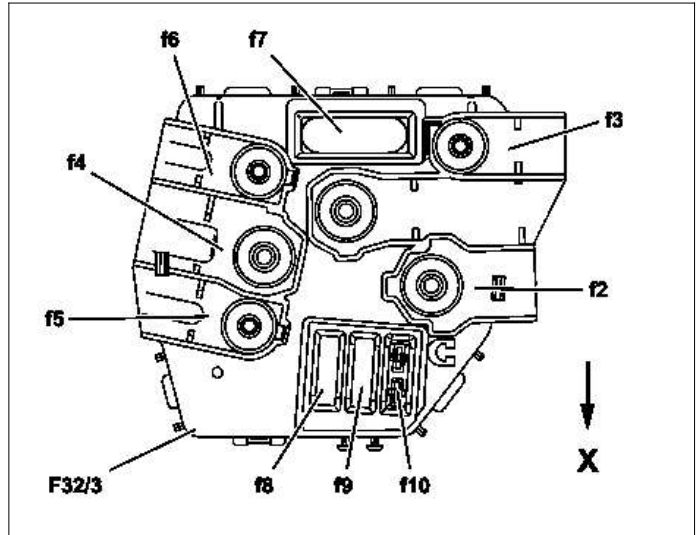

P54.15-3193-11

Fuse	Clamping device	Cable ID (cable fused)	Fused function	Rating in amperes (A)
f2	30	50.0 BK	<ul style="list-style-type: none"> <li>Alternator (G2)</li> </ul>	400
f3	30	10.0 RD  12.0 RD	<ul style="list-style-type: none"> <li>Valid for model 221 with engine 629, 642: <ul style="list-style-type: none"> <li>Glow time output stage (N14/3)</li> </ul> </li> <li>Valid for model 221.003/026/057/073/074/083/082/094/103/126/157/173/174/182/183/194, for model 221.054/056/080/084/086/087/154/156/180/184/186/187 as of 1.6.09, for model 221.070/170 as of 1.6.09 up to 31.8.10 without code (487) Active Body Control (ABC), for model 221.070/170 as of 1.9.10, for model 221.071/171 as of 1.6.09 without code (487) Active Body Control (ABC), for model 216.373/374/394: <ul style="list-style-type: none"> <li>Electrohydraulic power steering (A91/1)</li> </ul> </li> </ul>	150
f4	30	35.0 RD	<ul style="list-style-type: none"> <li>Interior prefuse box (F32/4)</li> </ul>	unfused
f5	30	12.0 RD	<ul style="list-style-type: none"> <li>AAC with integrated control additional fan motor (M4/7)</li> </ul>	100
f6	30	16.0 RD	<ul style="list-style-type: none"> <li>Front SAM control unit with fuse and relay module (N10/1)</li> </ul>	150
f7	30	4.0 RD	<ul style="list-style-type: none"> <li>Not valid for model 221.095/195: <ul style="list-style-type: none"> <li>ESP control unit (N47-5)</li> </ul> </li> <li>Valid for model 221.095/195: <ul style="list-style-type: none"> <li>Regenerative braking system control unit (N30/6)</li> </ul> </li> </ul>	40
f8	30	2.5 RDBK	<ul style="list-style-type: none"> <li>Not valid for model 221.095/195: <ul style="list-style-type: none"> <li>ESP control unit (N47-5)</li> </ul> </li> <li>Valid for model 221.095/195: <ul style="list-style-type: none"> <li>Regenerative braking system control unit (N30/6)</li> </ul> </li> </ul>	25
f9	30	2.5 RD	<ul style="list-style-type: none"> <li>Front SAM control unit with fuse and relay module (N10/1)</li> </ul>	25
f10	30	-	<ul style="list-style-type: none"> <li>Spare</li> </ul>	-