

MODEL 208

- 1 Bottom section of instrument panel
- 2 Cover
- 3 Cover
- 6 Handle
- 11 Cover
- 17 Housing
- 18 Round cover for electronic ignition switch control module (N73)

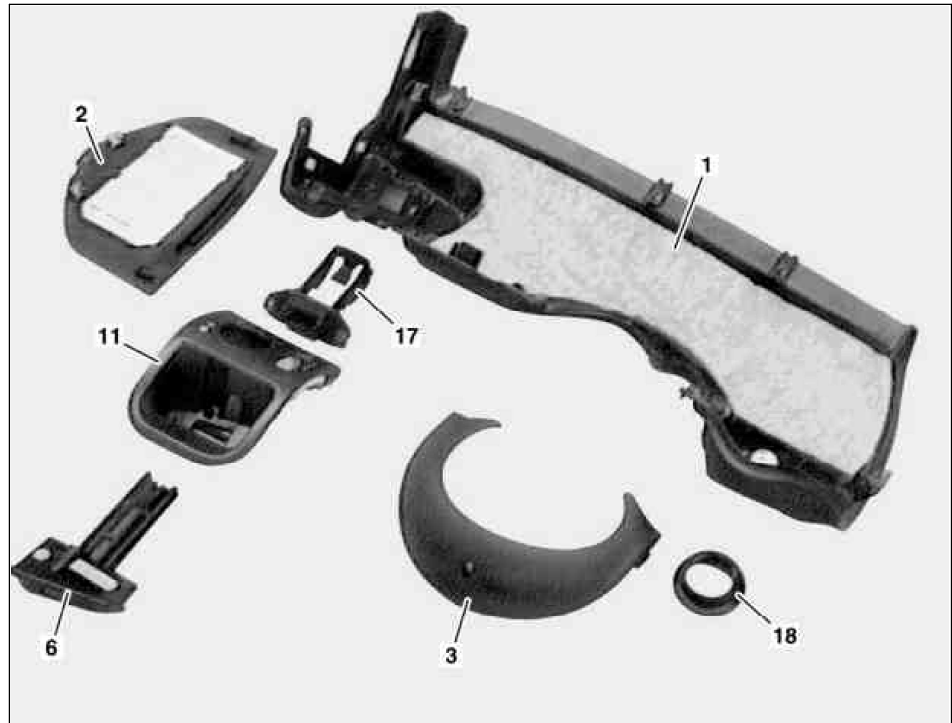

P68.10-0495-06

- 1 Bottom section of instrument panel
- 2 Cover
- 3 Cover
- 4 and 5 Screws
- 6 Handle
- 7,8,9 and 10 Screws
- 11 Cover
- 12 Switch (HRC)
- 13 and 14 Screws
- 15 Light module switch

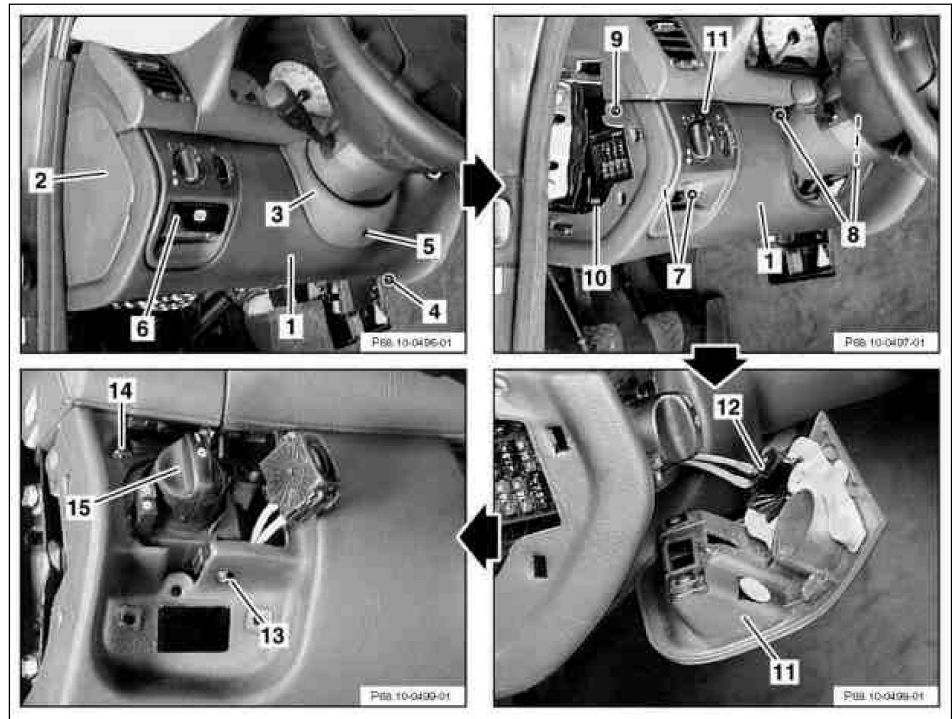

P68.10-0500-06

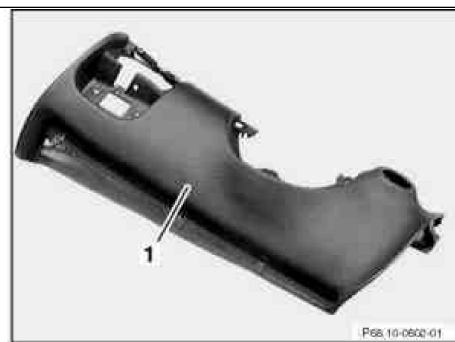
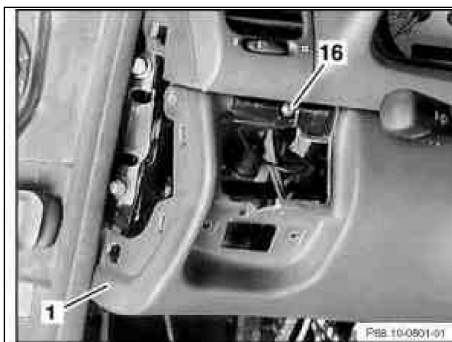

P68.10-0503-04

	Removal, installation		
1	Remove cover below instrument panel (left)		AR68.10-P-1500K
2	Unclip cover (2) and remove		*115589035900
3	Unscrew screws (4 and 5)		
4	Remove cover (3) downward		
5	Unhook control cable from handle (6) and remove handle (6)		
6	Unscrew screws (7) and remove housing (17) toward front		
7	Unscrew screws (8, 9 and 10)		
8	Unclip cover (11), unclip switch (12) and remove cover (11)		*115589035900
9	Unscrew screws (13 and 14) and pull light module switch (15) out toward front		
10	Unscrew screw (16) and remove bottom section of the instrument panel (1) downward		To completely remove the bottom section of the instrument panel (1) loosen electronic ignition switch control module (N73)
			*210589000700
11	Reinstall in opposite order		

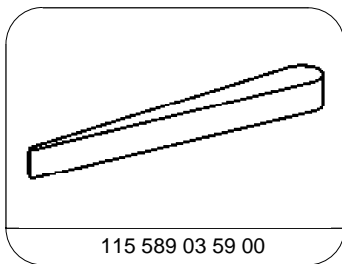

Long wedge

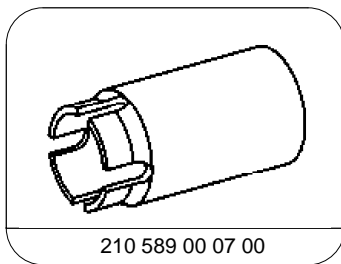

Slotted nut wrench for round cover plate on ignition switch