

MODELS 129.### ## as of 079795,  
140.### ## as of 123447,  
202,  
210 up to 31.5.99

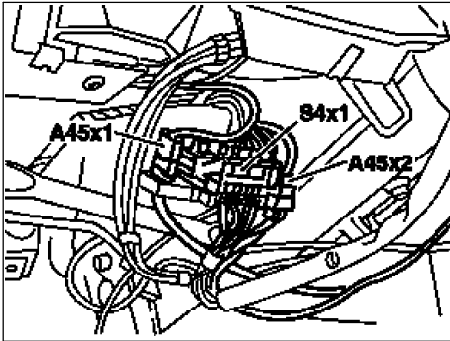

P46.10-0212-01

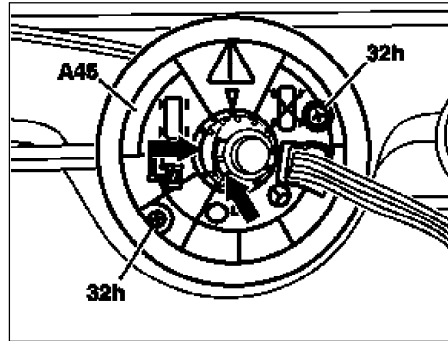

P46.10-0216-01

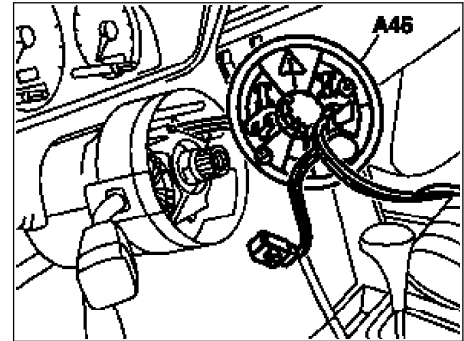

P46.10-0214-01

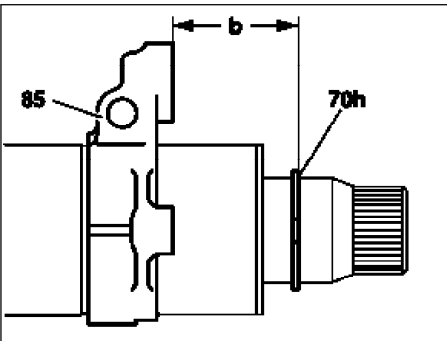

P46.10-0330-01

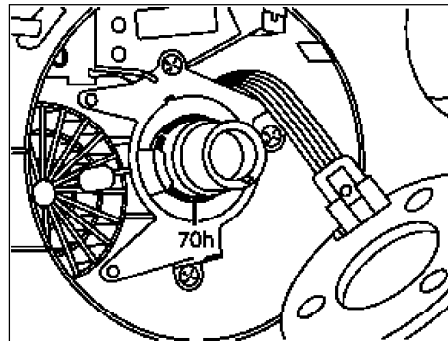

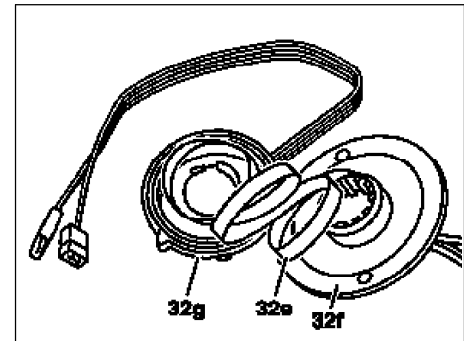

P46.20-0240-01



P46.10-0215-01

☒ ☒	Removing, installing		
1	Remove steering wheel	<b>i</b> Front wheels in straight-ahead position, steering wheel lock engaged.	AR46.10-P-0100B
2	Remove cover below instrument panel	Model 129. Model 140. Model 202. Model 210.	ra68001290150x ra68001400150x AR68.10-P-1500E AR68.10-P-1500F
3	Disconnect horn / airbag clock spring contact connector (A45x1) and expose cable		
4	Disconnect FAN relay module clock spring contact connector (A45x2) and expose cable		
5	Only unscrew fixing bolts (32h) as far as necessary to remove spring contact (A45)	<b>i</b> The fixing bolts also serve as an anti-rotation device and assembly aid.	
6	Carefully remove spring contact (A45) from jacket tube	<b>i</b> <b>Installation:</b> Push spring contact (A45) all the way on. The recess must be in alignment with the fixing lug (arrows). <b>ⓘ</b> If the spring contact was twisted, e.g. with steering coupling removed: @ Adjust the center position of the spring contact.	AR46.10-P-0200-01A
7	Ensure correct seat of locking ring (70h)		
☒	<b>Inspecting</b>		
8.1	Check distance (b) between locking ring (70h) and bracket (85)	Vehicles with electrically adjustable steering column <b>i</b> Only required if there are complaints of grinding noise: @ Models 129, 140, 210. <b>Nm</b> Models 129, 140. <b>Nm</b> 210.	AR46.10-P-0600-01B *BE46.10-P-1003-03A *BA46.10-P-1006-03A *BA46.10-P-1015-03D

BE

9	Check spring contact (A45) for damage	Visual inspection  The upper (32f) and lower part (32g) of the spring contact are clipped together and can only be separated by excessive force or incorrect assembly. If the spring contact is assembled incorrectly, carefully unwind and clip the upper and lower parts together. Be careful not to trap or bend the spring contact (32e).  <b>Do not use oil or grease</b>	
10	Install in the reverse order		

#### Test values for jacket tube

Number	Designation	Model 129	Model 140	Model 210
BE46.10-P-1003-03A	Dimension "b" from upper bracket to jacket tube	30+0.5	30+0.5	30+0.5
	See figure	AR46.10-P-0600-01B	AR46.10-P-0600-01B	AR46.10-P-0600-01B

#### Jacket tube

Number	Designation	Model 129	Model 140
BA46.10-P-1006-03A	Clamp screw, upper bracket to jacket tube	Nm 5	5

#### Jacket tube

Number	Designation	Model 210
BA46.10-P-1015-03D	Clamp screw, upper bracket to jacket tube	Nm 5