

MODEL 202 with CODE (956a) Sport
 MODEL 202 with CODE (955a) Elegance
 MODEL 202 up to 31.5.94 with CODE (959a) Esprit
 MODEL 208.3

- 1 Trim strip
 - 2 Instrument panel
 - 3 Studs (without nuts)
 - 4 Studs (with nuts)
 - 5 Push-in type clip
 - 6 Sliding clips
- Arrow = direction for removing and installing trim strip (1)

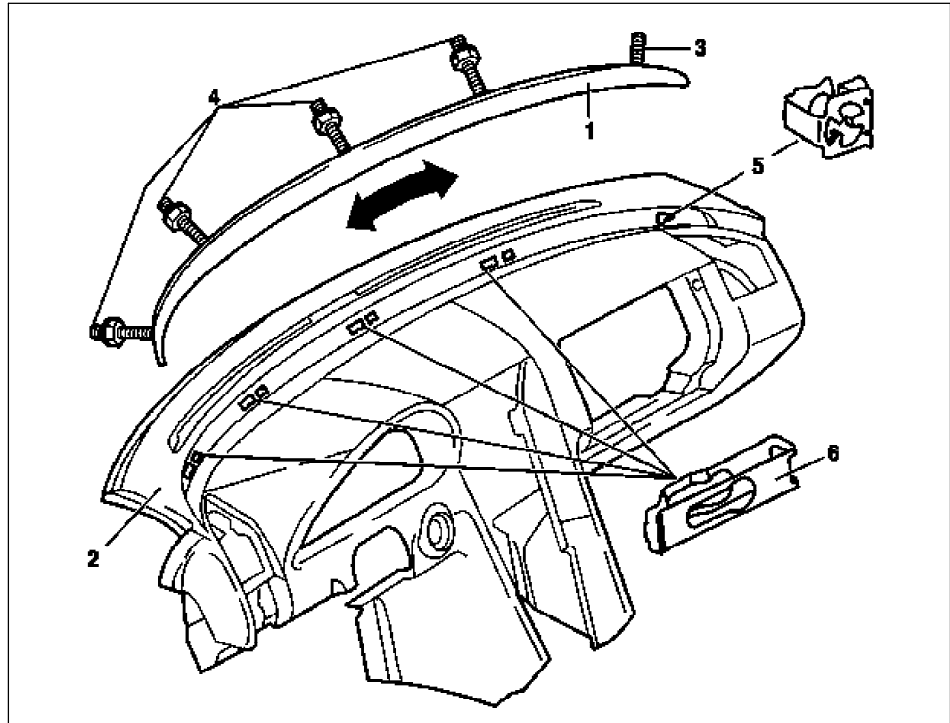

P68.10-0227-06

- 1 Trim strip
 - 2 Instrument panel
 - 3 Studs (without nuts)
 - 4 Studs (with nuts)
 - 5 Push-in type clip
 - 6 Sliding clips
- Arrow = direction for removing and installing trim strip (1)

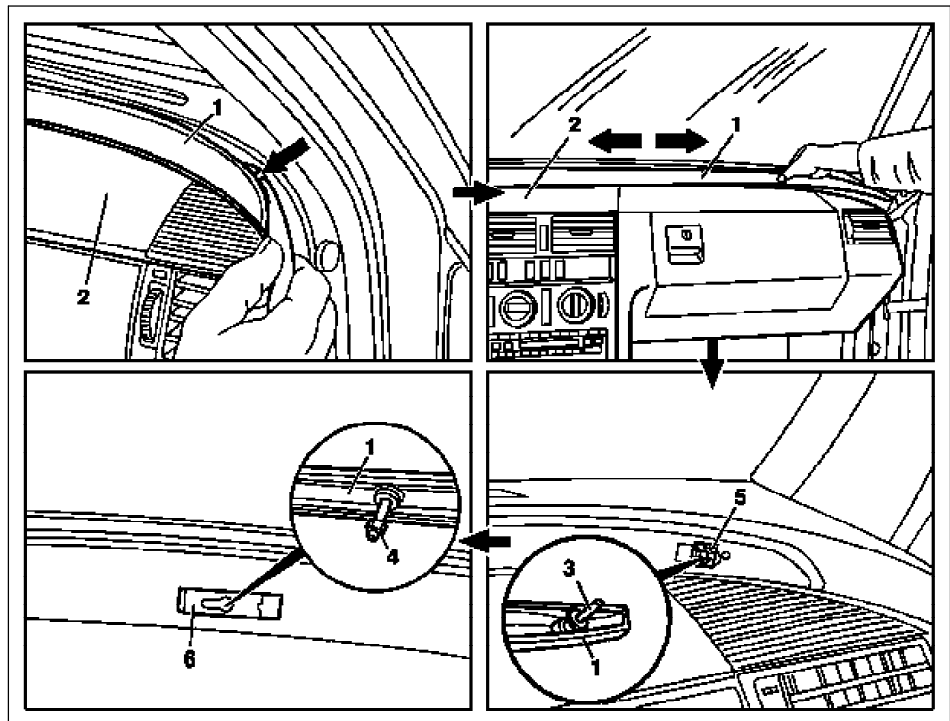

P68.10-0237-06



Removal

1	Remove stud (3, without nut) on trim strip (1) on right side from push-in clip (5) with plastic wedge.	<p>i On some vehicles a nut was installed on the stud (3) to fit the trim strip (1) better</p> <p>w Always remove nut before disassembling.</p> <p>i For this purpose remove glove compartment and unscrew nut (8 mm) on stud through this opening. Replace insert clip (5) after removing trim strip (1)</p>	
2	Pull trim strip (1) toward right and then move stud (4, with nuts) out of sliding clips (6) in instrument panel (2)		
3	Remove trim strip (1)		
	Installation		
4	Position trim strip (1) in instrument panel (2) with studs (4, with nuts) in sliding clips (6) and slide to left against stop		
5	Press stud (3, without nut) into push-in type clip (5) on right side and lock in place		

Special tool

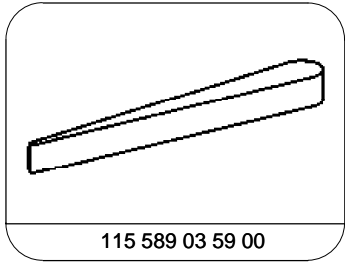

115 589 03 59 00

Long wedge