

Exhaust Layout

Fatz 2008 CLK550
June 2013

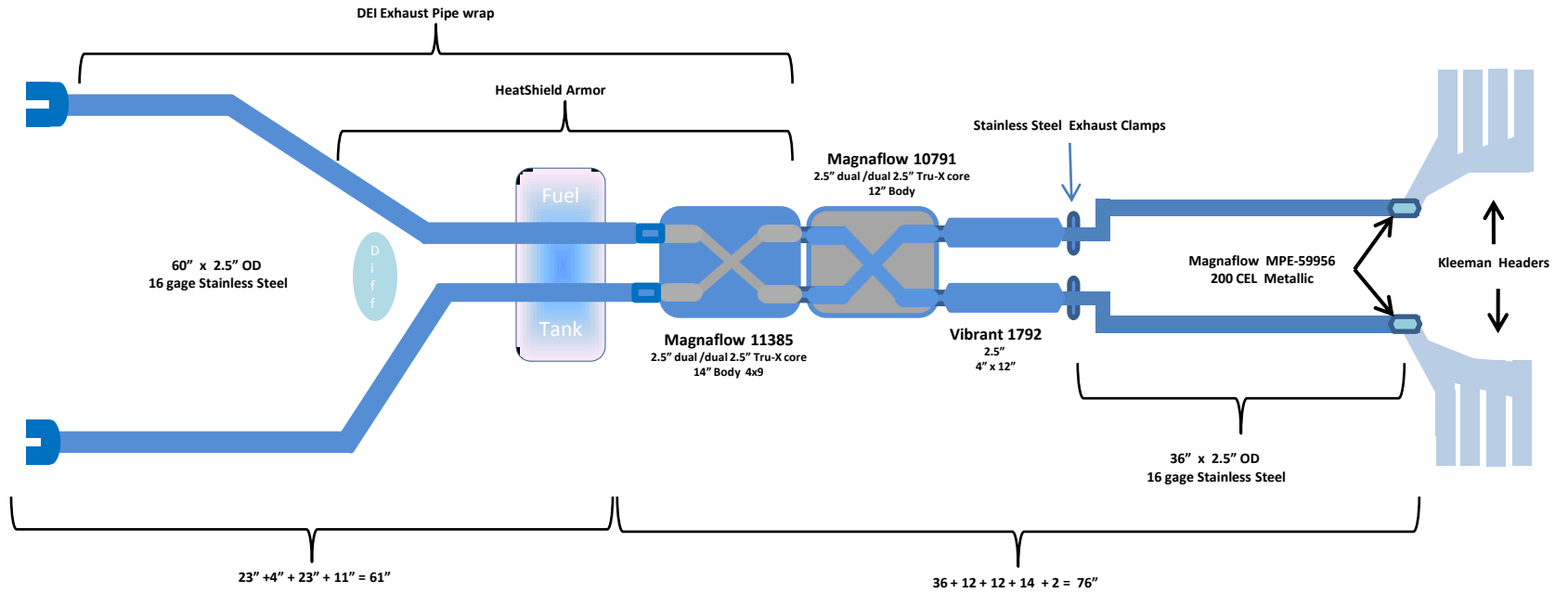

Exhaust Tips Alignment

Fatz 2008 CLK550
June 2013

View From Rear

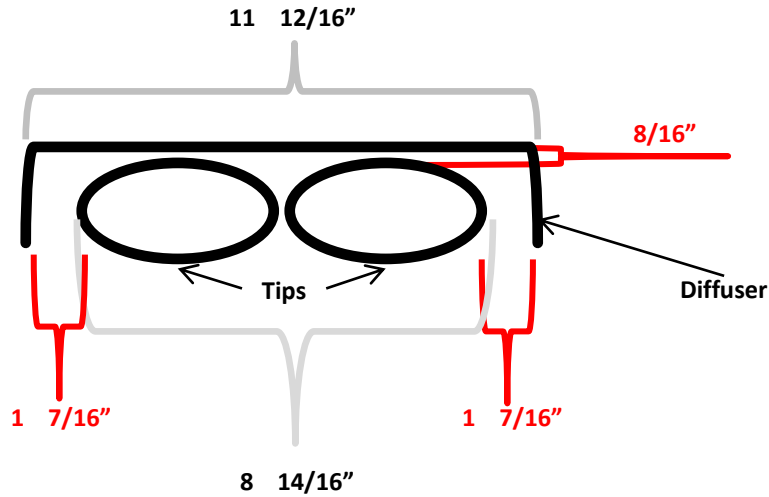

$11 \frac{12}{16} - 8 \frac{14}{16} = 2 \frac{14}{16}$
 $(2 \frac{14}{16}) / 2 = 1 \frac{7}{16}$
Measurements made from inner walls of diffuser opening

View From Top

Drivers Side

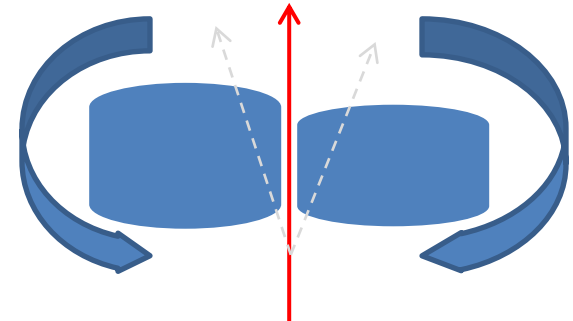

0 degree lateral rotation

View From Top

