

ENGINES 112

Air filter positioned at vehicle side

ENGINES 113

Air filter positioned at vehicle side





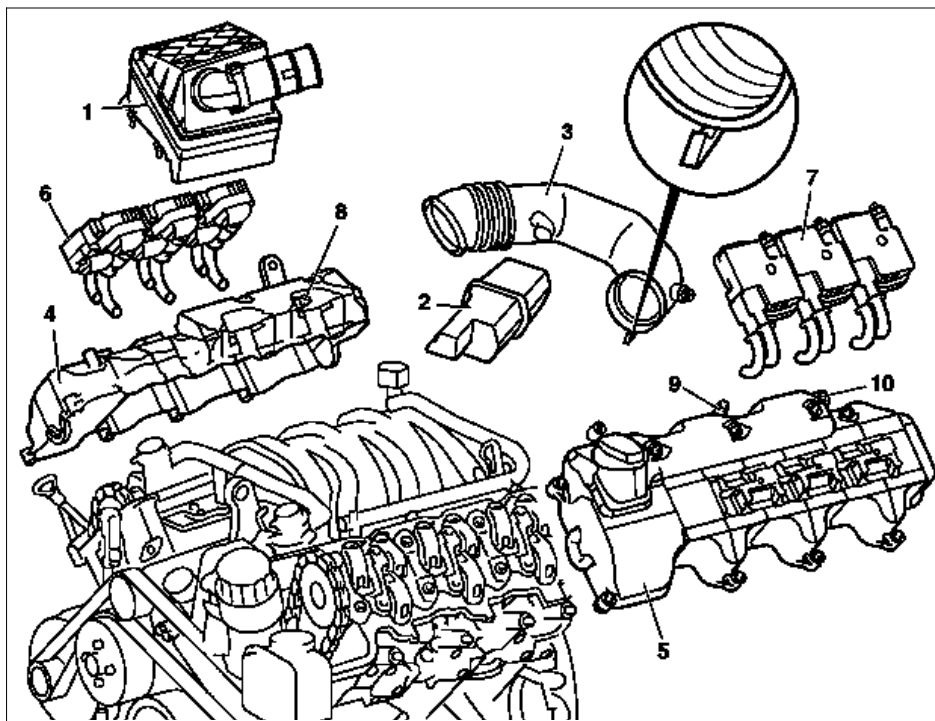

Shown on engine 112

- 1 Air cleaner housing
- 2 Resonance unit
- 3 Resonance tube
- 4 Right cylinder head cover
- 5 Left cylinder head cover
- 6 Right ignition coils
- 7 Left ignition coils
- 8 Right connection
- 9 Left connection
- 10 Left connection



P01.20-0221-06

☒ ☒	Remove/install		
i		☒ External torx set ☒ Torx bit set	*001589760900 *000589011000
1	Remove engine trim panel		
2	Remove air filter housing (1).		
3	Remove resonance body (2)		
4	Remove the resonance tube (3) with hot film mass air flow sensor	i At this time pull out the hot film mass air flow sensor plug. Ⓜ Removal: Pay attention to the mounting projection of the resonance tube (3)! All except model 163 with engine 113.942/981 Model 163 with engine 113.942/981	AR07.07-P-1454A AR07.07-P-1454MV
5	Unbolt dipstick guide tube of automatic transmission		
6	Unbolt ignition coils (6, 7) at cylinder head covers	Nm	AR15.12-P-2003A *BA01.20-P-1002-01E
7	Disconnect spark plug connectors	i Pay attention to markings for spark plug connectors on cylinder head covers and ignition coils ☒	*110589010100
8	Detach the vacuum hoses at connections (8, 9) of the cylinder head covers		
9	Detach crankcase ventilation hose at cylinder head cover fitting (10)	i Only on left side.	
⚠ Danger!	Risk of explosion caused by ignition of flammable products, risk of poisoning caused by inhaling fuel vapors or swallowing fuel as well as risk of injury to skin and eyes exposed to fuel.	No fire, sparks, open flames or smoking. Pour fuels only into suitable and appropriately marked containers. Wear protective clothing when handling fuel.	AS47.00-Z-0001-01A

10	Disconnect fuel line at fuel rail	 Only in case of vehicles with a non-flexible fuel line. Release fuel pressure through service valve!  Pressure hose  	*119589046300 *BA07.52-P-1001-01A *BA07.52-P-1001-01A
11	Remove cylinder head covers (4, 5)	  Installation: Ensure cylinder head cover gasket is correctly installed.	*BA01.20-P-1001-01E AR01.20-P-5014-01B
12	Install in the reverse order		
 Danger!	Risk of accident caused by vehicle starting off by itself when engine is running. Risk of injury caused by contusions and burns during starting procedure or when working near the engine as it is running	Secure vehicle to prevent it from moving by itself. Wear closed and snug-fitting work clothes. Do not touch hot or rotating parts.	AS00.00-Z-0005-01A
13	Check for leaks with engine running		

 **Crankcase ventilation, cylinder head cover**

Number	Designation	Engine 112	Engine 113
BA01.20-P-1001-01E	Cylinder head cover bolt	Stage 1 Nm 9	9
		Stage 2 4° -	-
BA01.20-P-1002-01E	Bolt, ignition coils to cylinder head cover	Nm 8	8

 **Fuel distributor**

Number	Designation	Engine 112 except 112.945/951/960/961	Engine 112.945	Engine 112.951/976	Engine 112.960/961 AMG
BA07.52-P-1001-01A	Fuel feed line to fuel distributor	Nm 38	38	24	35

 **Fuel distributor**

Number	Designation	Engine 113.987	Engine 113.990/991	Engine 113.992/993/995	Engine 113.940/941/942/943/944/945/946/948/960/961/962/963/964/965/966/967/968/969/971/980/981/982/984/986/988

BA07.52-P-1001-01A	Fuel feed line to fuel distributor	Nm 38	38	38	38
--------------------	------------------------------------	-------	----	----	----

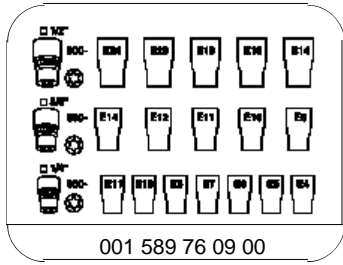

External Torx set

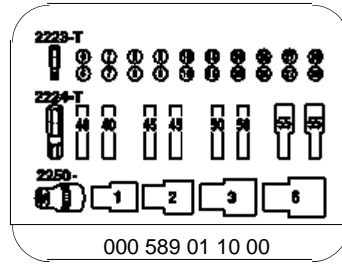

Torx bit set

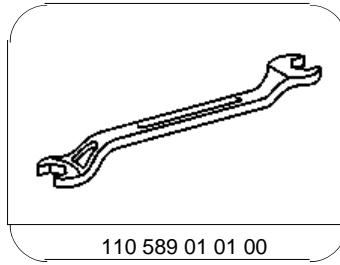

Open-end wrench, double

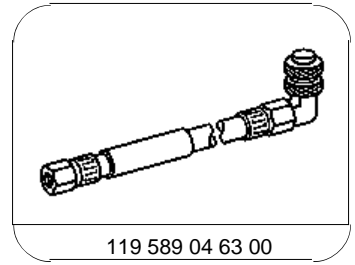

Pressure hose