

AR01.20-P-5014-01B	Ensure gasket of cylinder head cover is correctly installed		
--------------------	---	--	--

- 1 Inspect gasket (arrows) of cylinder head cover to ensure it is correctly located in the sealing groove of the cylinder head cover, particularly at the rear of the cylinder head.

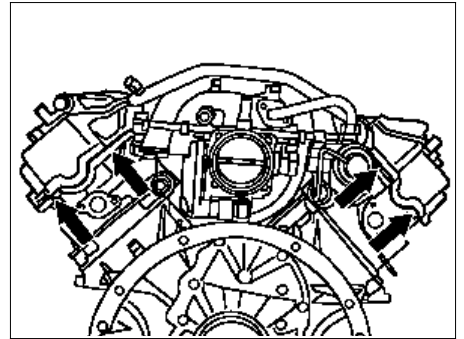

P01.20-0220-01