

MODEL 218

as of model year 2014

with CODE 489 (AIRMATIC (air suspension with continuous damper adjustment))

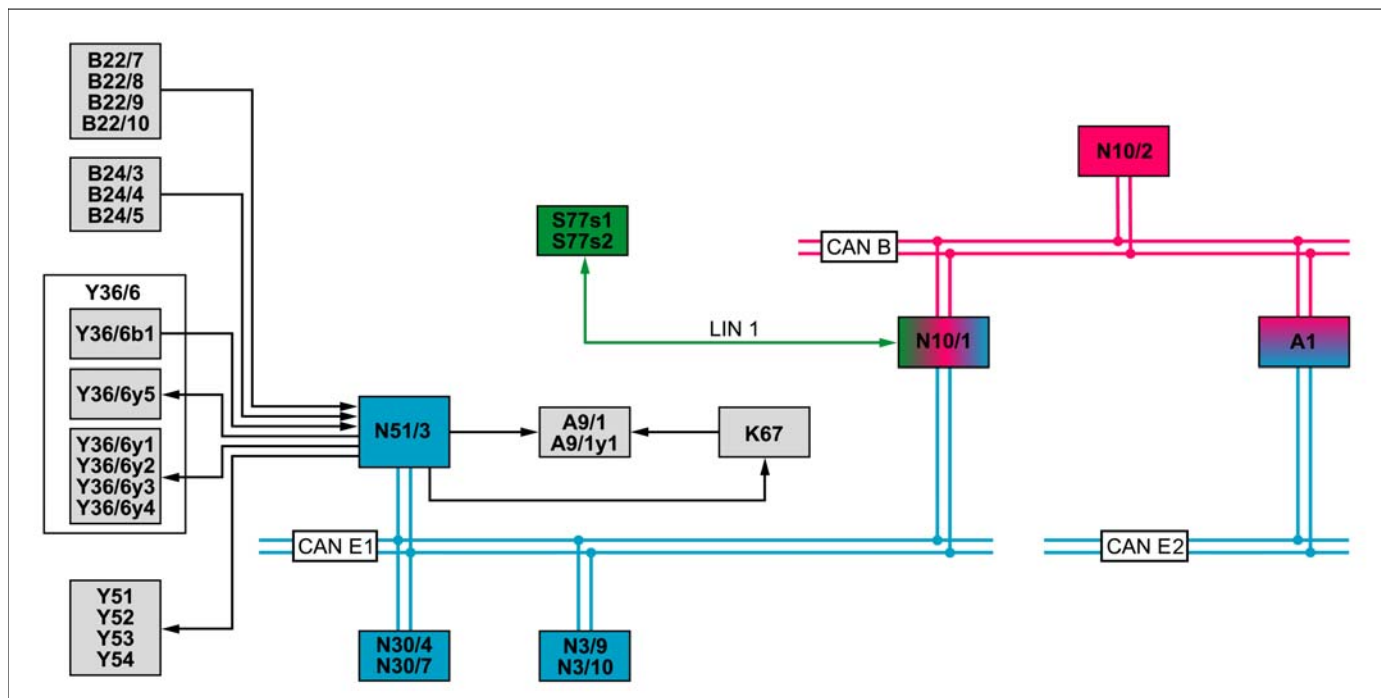

P32.22-2513-79

A1	Instrument cluster	CAN E2	Chassis CAN 2	Y36/6	AIRMATIC valve unit
A9/1	AIRMATIC compressor	K67	AIRMATIC relay	Y36/6b1	AIRMATIC pressure sensor
A9/1y1	AIRMATIC pressure reduction valve	LIN 1	Instrument panel LIN	Y36/6y1	Left front level control valve
B22/7	Left rear level sensor	N3/9	CDI control unit (with diesel engine)	Y36/6y2	Right front level control valve
B22/8	Left front level sensor	N3/10	ME-SFI [ME] control unit (with gasoline engine)	Y36/6y3	Left rear level control valve
B22/9	Right front level sensor	N10/1	Front SAM control unit with fuse and relay module	Y36/6y4	Right rear level valve
B22/10	Right rear level sensor	N10/2	Rear SAM control unit with fuse and relay module	Y36/6y5	AIRMATIC central reservoir filling valve
B24/3	Left front body lateral acceleration sensor	N30/4	Electronic Stability Program control unit (without CODE 233 (DISTRONIC PLUS))	Y51	Left front axle damping valve unit
B24/4	Right front body lateral acceleration sensor	N30/7	Premium Electronic Stability Program control unit (with CODE 233 (DISTRONIC PLUS))	Y52	Right front axle damping valve unit
B24/5	Left rear body lateral acceleration sensor	N51/3	AIRMATIC control unit	Y53	Left rear axle damping valve unit
CAN B	Interior CAN	S77s1	Electronic level control button	Y54	Right rear axle damping valve unit
CAN E1	Chassis CAN 1	S77s2	Comfort and Sport button		

Function requirements, general

- Engine speed > 0 rpm

The driver is made aware of the situation by the message "Vehicle being raised, please wait" on the instrument cluster. Through the

AIRmatic system, general

The AIRmatic system is the combination of an air suspension with a continuous damper adjustment in which the dampening is adapted on a wheel by wheel basis corresponding to the road surface condition and driving style.

After the ignition is switched on, the last selected level and the last adjusted damping stage are active.

The AIRmatic system consists of the following subfunctions:

- **Wake-up mode, function**
- **Air suspension, function**
- **Locking position, function**
- **Variable damping, function**
- **System and warning messages, function**

Wake-up mode, function

After the vehicle is unlocked, the AIRmatic control unit is activated (woken up) by the active chassis CAN 1 in order to check and, if necessary, correct the current vehicle level.

Level control is performed in wake-up mode (e.g. when the vehicle is being loaded and unloaded) without the AIRmatic compressor being activated, provided that the fill level of the AIRmatic central reservoir is sufficient.

A critical condition, for example a too low vehicle level at the front axle, in which the full wheel angle can no longer be guaranteed, is detected by the AIRmatic control unit as a fault.

wake-up of the AIRmatic control unit a chronological lead occurs which is used to correct the vehicle level. This reduces the amount of time which passes before level correction is performed, therefore increasing vehicle availability.

i The lifting up out of the critical level also initially takes place at the on-board electrical system voltage inadequate for this. The rear SAM control unit with fuse and relay module continuously evaluates the voltage of the on-board electrical system and interrupts or prevents the lifting process if necessary. Current-intensive consumers are shut down in a fixed sequence until a predetermined minimum voltage is reached again.

Air suspension, function

Under normal operating conditions, the air suspension operates with different pressures depending on the load. The AIRMATIC compressor is used to supply pressure. The AIRmatic compressor is activated by the AIRmatic control unit via the AIRmatic relay.

The compressed air is distributed to the individual suspension struts of the front axle and rear axle via the AIRMATIC valve unit.

The AIRmatic system has a central reservoir in which compressed air is stocked, in order to make possible rapid adjustment times of the vehicle level independent of the compressor operation.

The pressure in the AIRmatic central reservoir is monitored by the AIRmatic pressure sensor integrated in the AIRmatic valve unit. As soon as the pressure in the AIRmatic central reservoir drops below the threshold value, the AIRmatic compressor is activated.

The level control is realized by 4 air spring bellows. If the AIRmatic compressor or the AIRmatic central reservoir delivers compressed air to an air spring bellows via a corresponding valve in the AIRmatic valve unit, the vehicle level at the affected wheels increases.

Conversely, the vehicle level decreases when air from the air suspension bellows is released by the corresponding valve in the AIRmatic valve unit and released at the AIRmatic pressure reduction valve in the AIRmatic compressor.

By operating the electronic level control valve in the LCP the driver can select between the normal level (NN) and an increased level (EN1), each button operating causing a change to the respective other level. Actuation of the electronic level control button is read in by the front SAM control unit with fuse and relay module via the instrument panel LIN and sent to the AIRmatic control unit via chassis CAN 1. The actuation of the LED in the electronic level control button takes place in the opposite way.

i The levels and the transient conditions can differ depending on the variant.

Speed for chassis adjustment Comfort	$v < 150 \text{ km/h}$	$v \geq 150 \text{ km/h}$	$v \geq 200 \text{ km/h}$	$v \leq 190 \text{ km/h}$	$v \leq 90 \text{ km/h}$
Level reduction	0 mm	-10 mm	-10 mm	-10 mm	0 mm

Speed for chassis adjustment Sport	$v < 150 \text{ km/h}$	$v \geq 150 \text{ km/h}$	$v \geq 200 \text{ km/h}$	$v \leq 190 \text{ km/h}$	$v \leq 90 \text{ km/h}$
Level reduction	-10 mm	-10 mm	-10 mm	-10 mm	-10 mm

Speed for level adjustment EN1 (+25 mm)	$v < 80 \text{ km/h}$	$v \geq 80 \text{ km/h}$ after $t > 3 \text{ min.}$	$v \geq 120 \text{ km/h}$
--	-----------------------	--	---------------------------

Level	+25 mm	Mean sea level (0 mm)	Mean sea level (0 mm)
-------	--------	-----------------------	-----------------------

Locking position, function

To ensure that, when intentionally raising the vehicle (e.g. with a vehicle jack), compressed air is not continuously released from the suspension struts (which would lower the vehicle), it is necessary to detect this reduction in wheel load automatically and then to initiate a locking position. The locking position is a pure software function which prevents the actuation of the level control valves (draining process). If the locking position is detected by the AIRmatic control unit, no display and no fault memory takes place in the IC.

The locking position is canceled automatically if the AIRmatic control unit receives wheel speed signals from the left front and right front with $v \neq 0$ km/h from the Electronic Stability Program control unit (without CODE 233 (DISTRONIC PLUS)) or from the Premium Electronic Stability Program control unit (with CODE 233 (DISTRONIC PLUS)) via chassis CAN 1. The level control functions are then reactivated.

The output stage actuations of the AIRmatic control unit via the diagnosis take place independent of the locking status and are thus always possible.

Variable damping, function

The electronically regulated, continuous damping system operates fully automatically.

It provides improved driving comfort and driving safety, compared to the conventional steel suspension.

Damping is set harder or softer by the electronics of the AIRmatic control unit depending on the driving situation.

If the sensor system records a sporty driving style for example, the comfortable basic damping becomes harder automatically.

This automatic program can be adjusted by the driver via the Comfort and Sport button in the lower control panel to a more sporty or more comfortable characteristic.

The operation of the Comfort and Sport button is read in by the front SAM control unit with fuse and relay module via the instrument panel LIN and is supplied to the AIRmatic control unit via the chassis CAN 1. The actuation of the two LEDs in the Comfort and Sport button takes place in the opposite way.

The electronics works continuously within a broadly spread damping performance map.

The damping force is adapted individually and automatically at each wheel to match the current requirements, the road condition and the driving conditions.

As a result, the vehicle rolls smoothly even on poor road surfaces, without impairing driving stability.

The AIRmatic control unit uses the left front level sensor, right front level sensor, left rear level sensor and right rear level sensor to determine the current vehicle level and shock absorber speeds.

The AIRmatic control unit determines the body acceleration of the vehicle via the left front body acceleration sensor, right front body acceleration sensor and left rear body acceleration sensor.

Based on the input signals, the AIRmatic control unit determines the optimum damping stage for each shock absorber and directly actuates the left front axle damping valve unit, right front axle damping valve unit, left rear axle damping valve unit and right rear axle damping valve unit accordingly. These can be adjusted for each wheel, i.e. the damping can be adjusted continuously at each individual wheel.

System and warning messages, function

System and warning messages with safety and system-relevant instructions for the driver are displayed on the instrument cluster.

To display the messages, the AIRmatic control unit sends corresponding messages to the instrument cluster via chassis CAN 1 and the interior CAN with the front SAM control unit with fuse and relay module interface. There are various system and warning messages with different fault priorities, depending on the severity of the fault and the urgency of the request for action to be taken.

If several faults exist at the same time, several fault messages will be issued accordingly.

Texts displayed in instrument cluster:

- "Stop, car too low", in addition signal tone
- "Vehicle being raised, wait briefly"
- "Fault", no signal tone

The following system message is also displayed in the instrument cluster:

- "Vehicle is lifting up", no signal tone

	Electrical function schematic for AIRmatic		PE32.32-P-2050-97XAB
	Overview of AIRmatic system components		GF32.22-P-9998FQ