

MODEL 219.3 with CODE (489) Aromatic (semi-active air suspension)

- 1 Valve unit
 1a Bolt
 2 Bracket
 2a Bolt
 3 Pin
 4 Rubber bushing

- A9/1 AIRmatic compressor unit
 E1 Left front lamp unit

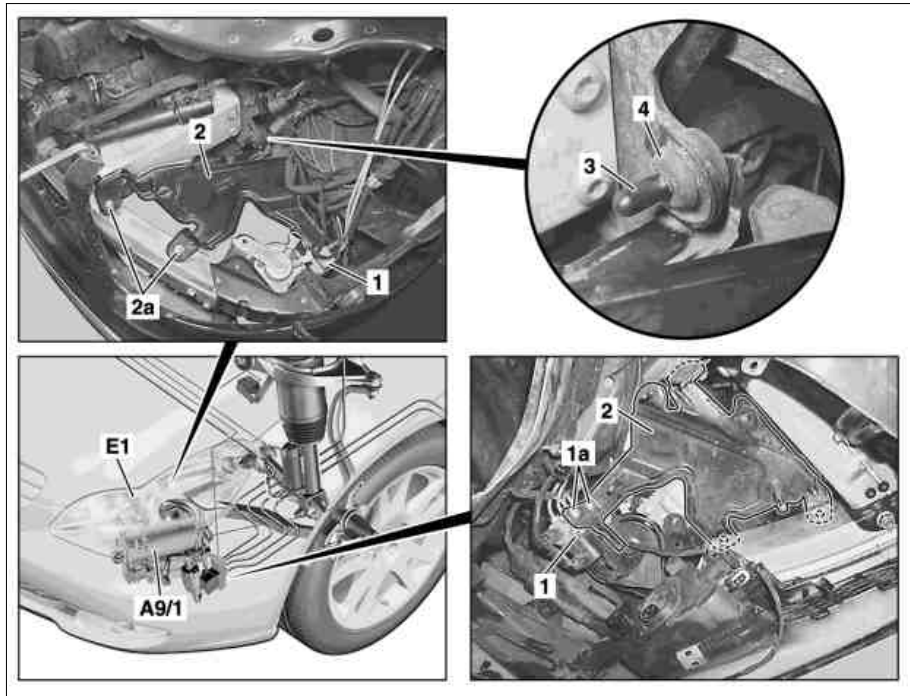

P32.22-2360-06

- 2 Bracket

- A Stop buffer and attaching parts
 A9/1 AIRmatic compressor unit

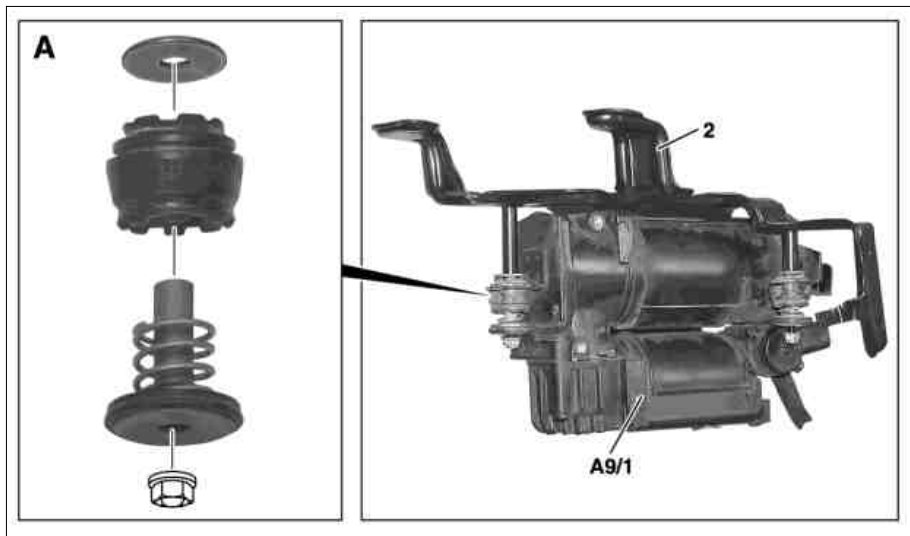

P32.22-2353-05

	Remove/install		
1	Remove AIRmatic compressor unit (A9/1)		AR32.22-P-2001TX
2	Undo bolts (1a) and place valve unit (1) to one side.	Do not disconnect pressure lines and electrical connectors. 	*BA32.22-P-1011-03A
3	Remove left front lamp unit (E1)		AR82.10-P-4730TX
4	Remove bolts (2a)		*BA32.22-P-1012-03A
5	Apply liquid lubricant to bolts (3).	Lubricant	*BR00.45-Z-1002-06A
6	Slide bracket (2) of AIRmatic compressor unit (A9/1) backwards out of rubber mount (4) and remove		
	Checking		
7	Check rubber mount (4) of bracket (2)	Check rubber mount (4) for hardness and damage; replace if necessary.	
8	Replace stop buffer and attaching parts (A) of the AIRmatic compressor unit (A9/1)	If reusing the stop buffer and attaching parts (A) knocking and thumping noise may occur.	AR32.22-P-2011TX
9	Install in the reverse order		

Nm Air suspension

Number	Designation	Model 219 with AIRmatic code 489
BA32.22-P-1011-03A	Bolt for valve unit to compressor bracket	Nm 5
BA32.22-P-1012-03A	Bolt for compressor bracket to front crossmember	Nm 8

Repair materials

Number	Designation	Order number
BR00.45-Z-1002-06A	Lubricating paste, rubber parts 2.5 kg, DB supply specification 6867.00	A 000 989 01 60