

Engine 256.9 in model 167

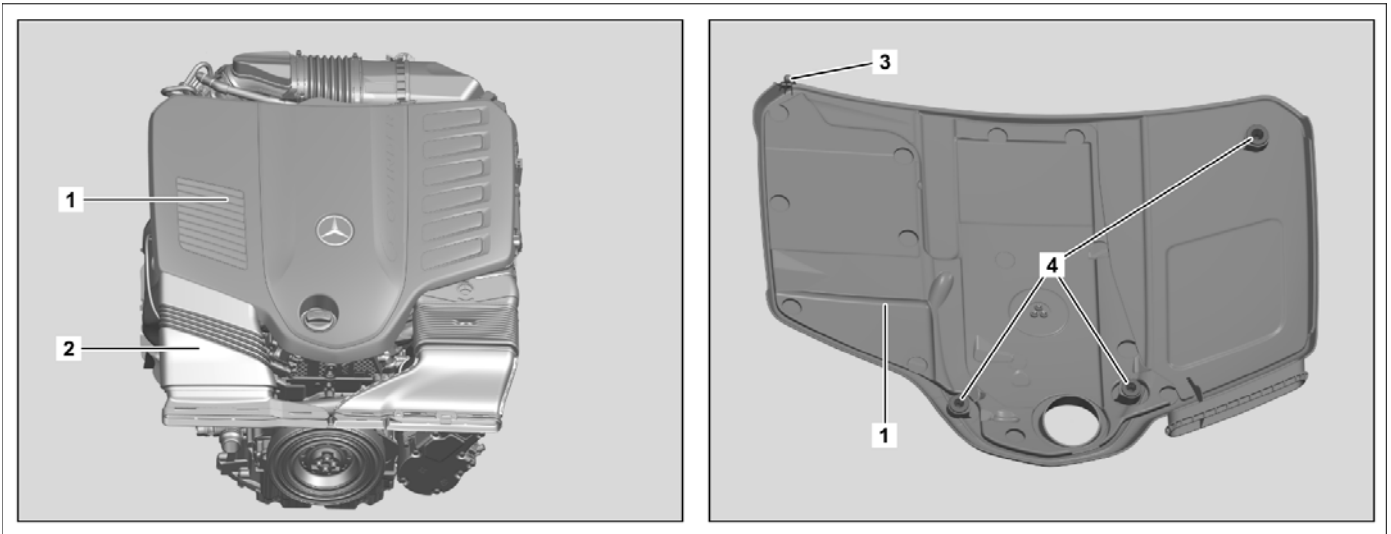

P01.10-3379-08

- 1 Engine cover
2 Cold air guide

- 3 Ball head
4 Elastomer bearing

Caution	Risk of injury caused by scraping or cutting body parts on sharp vehicle parts	Always wear protective gloves when working on or near sharp and non-deburred vehicle parts. Deburr repair panels.	AS00.00-Z-0017-01A
	Remove/install		
1	Release cold-air ducting (2) at cold air intake manifold.		
2	Detach ball head (3) from the elastomer bearing on the air filter housing.	Installation: Coat elastomer bearing at air filter housing with antiseize paste. Lubricant, rubber assembly 1 l	*BR00.45-Z-1010-06A
3	Release elastomer bearings (4) and remove engine cover (1) with cold-air ducting (2) in upward direction.	Installation: Coat elastomer bearings (4) with antiseize paste. Lubricant, rubber assembly 1 l	*BR00.45-Z-1010-06A
4	Check the elastomer bearings (4) and the elastomer bearing at the air filter housing for damage, and replace them if necessary.		
5	Install in the reverse order.		

Repair materials

Number	Designation	Order number
BR00.45-Z-1010-06A	Lubricant, rubber assembly 1 l	A 000 989 03 67