

# AMG GT Coupe



C190

Model Year 2020

Pricing Preliminary

**AMG**  
DRIVING PERFORMANCE

## Important note

The information presented in this guide is based on the most current information available and is intended for internal use only. Mercedes-Benz reserves the right to make changes at any time, without notice, to colors, materials, equipment, special specifications and models.

Pricing may not yet be finalized for some models or options.

Due to variances among monitors and printers the colors that appear on your screen and printouts may not be exact.

For illustrative purposes, some images may show vehicles with European Specification.

## Revision History

<i>Date</i>	<i>Changes</i>
11/2018	Initial Release
01/2019	DE7 Carbon Fiber Package I – Delayed until 1 <sup>st</sup> decade of July for GT R

## *GT | GT C | GT R*

---



Models



What's new



Standard Equipment



Exterior Paint Colors



Wheels



Interior Upholstery



Interior Trims



Option Packages



Stand-Alone Options



Options in Detail



Highlights

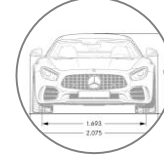

Specifications



**GT (190.377)**

- MSRP \$115,800
- Handcrafted AMG 4.0L V8 biturbo engine
- 469 hp
- 465 lb-ft
- 3.9 sec (0-60 mph)
- Launch Date: Summer 2019



**GT C (190.380)**

- MSRP \$150,800
- Handcrafted AMG 4.0L V8 biturbo engine
- 550 hp
- 502 lb-ft
- 3.6 sec (0-60 mph)
- Launch Date: Summer 2019



**GT R (190.379)**

- MSRP \$162,800
- Handcrafted AMG 4.0L V8 biturbo engine
- 577 hp
- 516 lb-ft
- 3.5 sec (0-60 mph)
- Launch Date: Summer 2019

## *Standard Equipment*

- P44 – Parking Package – Now includes a Front Camera
- U88 – AMG Drive Unit Steering Wheel Controls
- U78 – AMG Performance Exhaust will now be standard for all GT Coupes
- NTG 5.5 including Apple CarPlay, Android Auto, and AMG Track Pace
- New 12.3” fully digital instrument cluster
- New 10.25” multimedia center display
- Newly designed high performance LED headlights

## *New Optional Equipment*

- 446 – Touchpad only option (replaces control knob on center console)
- 568 – Exclusive Nappa Leather in Silver Pearl/Black with Diamond Stitching (GT C only)
- 644 – designo Brilliant Blue Magno exterior color
- RXN – New Y-Spoke design wheel in titanium gray (GT only)
- RXQ – New Split 10-Spoke forged wheel in titanium gray (GT C only)
- RXR – New Split 10-Spoke forged wheel in black (GT C only)

## *New Limited-Edition GT R PRO*

- Limited to 150 units in the US
- Manually adjustable coil over suspension
- Standard Carbon Ceramic Brakes, Exclusively painted black with white lettering
- Functional “gills” on front fenders
- Larger front splitter with aluminum supports providing greater front axle downforce
- Adjustable Carbon Fiber Sway Bar on front axle
- Exclusive Carbon Fiber Roof
- Standard Matte Carbon Fiber Interior Trim and Crossbar, Carbon Fiber Package I, and Carbon Fiber package II

## *Newly designed LED Headlights and Tail lights*



## *New Model Specific Exhaust Tips*



GT Receives Double Round Exhaust Tips



GT C Receives Double Trapezoid Exhaust Tips

\*GT R will keep it's previous exhaust configuration

## *Performance & Handling*

- Handcrafted AMG 4.0L V8 biturbo engine
- AMG SPEEDSHIFT® DCT 7-speed transmission
- AMG High-Performance Composite Braking System
- AMG Performance seats
- Next Generation AMG Performance steering wheel
- AMG DYNAMIC SELECT
- AMG Drive Unit Steering Wheel Buttons
- Automatically-deployed rear spoiler
- AMG Sport Suspension
- 3-stage ESP®
- Summer Performance Tires
- AIRPANEL Active Aerodynamic System for enhanced cooling
- Rear Differential, AMG mechanical limited-slip (GT only)
- Rear Differential, AMG electronic limited-slip (GT C only)
- 14.2" Front & Rear brakes with Silver-painted brake calipers (GT)
- 15.4" Front & 14.2" Rear brakes with Red-painted brake calipers (GT C)
- Absorbent glass mat battery (GT only)
- Lithium-ion battery (GT C only)
- AMG Performance Exhaust System
- AMG RIDE CONTROL Sport Suspension with 3-stage adjustment (GT C)

## *Comfort & Convenience*

- Power/Heated/Memory AMG Performance seats
- 4-way power steering column
- AMG stainless steel door sill covers
- MercedesMe Connect with trial period
- Power/Memory/Dimming/Folding mirrors
- Rear load space cover and cargo net
- Trickle charger prewiring (includes accessory trickle charger)
- COMAND® Navigation
- Dual-zone climate control
- Active LED Headlamps with Intelligent High Beam Control
- AMG Track Pace
- NTG 5.5 with Apple CarPlay and Android Auto
- AMG Performance steering wheel - Full Nappa (GT)
- AMG Performance steering wheel - Full DINAMICA (GT C)
- 4-speaker sound system (GT only)
- Burmester® Surround Sound System (GT C)
- KEYLESS-GO® (GT C)
- Affalterbach crest pressed into center console lid (GT C)
- Exclusive Nappa Leather Interior (GT C)
- AMG Illuminated Door Sills (GT C)
- Fixed Panorama Roof (GT C)
- Heated/Ventilated Seats (GT C)
- 12.3" fully digital instrument cluster
- 10.25" Multimedia center display

## *Safety & Security*

- Rearview and Front Cameras
- PRE-SAFE® System
- Active Brake Assist
- 8 Standard air bags including driver and passenger knee air bags
- PARKTRONIC®
- Lane Tracking Package (GT C)

## *Performance & Handling*

- Handcrafted AMG 4.0L V8 biturbo engine
- AMG SPEEDSHIFT® DCT 7-speed transmission
- AMG High-Performance Composite Braking System
- AMG Performance seats
- Next Generation AMG Performance steering wheel
- AMG DYNAMIC SELECT
- 19" / 20" AMG Forged Wheels
- Fixed rear spoiler and enhanced aerodynamics
- 9-Mode AMG TRACTION CONTROL
- AMG RIDE CONTROL Sport Suspension
- Michelin Pilot Sport Cup 2 Tires
- AIRPANEL Active Aerodynamic System for enhanced cooling
- Lower Carbon Fiber aerodynamic profile for enhanced traction
- Rear Differential, AMG electronic limited-slip
- 15.4" Front & 14.2" Rear brakes
- Yellow brake calipers
- Active rear-axle steering
- Carbon fiber roof panel
- 1" wider wheels/tires front and rear
- Carbon fiber drive shaft and torque tube
- AMG Performance Exhaust System
- AMG Drive Unit Steering Wheel Buttons

## *Comfort & Convenience*

- Power/Heated/Memory AMG Performance seats
- 4-way power steering column
- AMG stainless steel door sill covers
- MercedesMe Connect - with trial period
- Rear load space cover and cargo net
- Trickle charger prewiring (includes accessory trickle charger)
- COMAND® Navigation
- Dual-zone climate control
- AMG Track Pace
- Active LED Headlamps with Intelligent High Beam Control
- AMG Performance steering wheel - Full DINAMICA
- 12.3" fully digital instrument cluster
- 10.25" Multimedia center display
- 4-speaker sound system *(for weight reduction)*

## *Safety & Security*

- Rearview and Front Cameras
- Active Brake Assist
- 8 Standard air bags including driver and passenger knee air bags
- PARKTRONIC®



	Feature	Mercedes-AMG GT	Mercedes-AMG GT C	Mercedes-AMG GT R	
	<b>Bodystyles</b>	Coupe, Roadster	Coupe, Roadster	Coupe	
<b>Optional Features</b>	<b>Exclusive Nappa Leather</b>	N/A Coupe	Standard	Optional, Nappa/DINAMICA Only	
	<b>Lane Tracking Package</b>	Optional	Standard	Optional (For Weight)	
	<b>AMG Dynamic Plus Package</b>	N/A	Standard	Standard	
	<b>AMG High Performance Ceramic Composite Braking System</b>	N/A	Optional	Optional	
	<b>Horsepower</b>	469 @ 6,000 rpm	550 @ 6,750 rpm	577 @ 6,250 rpm	
<b>Standard Performance Features</b>	<b>Torque</b>	465 lb.-ft. @ 1,900-5,000 rpm	502 lb.-ft. @ 2,100-5,750 rpm	516 lb.-ft. @ 2,100-5,500 rpm	
	<b>Top Speed</b>	189 mph	196 mph	198 mph	
	<b>Body design</b>	Normal	Widebody rear	Widebody, Carbon-fiber front fenders	
	<b>Active Aerodynamics</b>	AIRPANEL, Front	AIRPANEL, Front	AIRPANEL with Carbon Fiber Profile	
	<b>Battery</b>	Absorbent Glass Mat	Lithium Ion	Lithium Ion	
	<b>AMG High Performance Composite Braking System</b>	14.2”F/ 14.2”R	15.4”F/ 14.2”R, Red Caliper	15.4”F/ 14.2”R, Yellow Caliper	
	<b>AMG Rear Differential Lock</b>	Mechanical	Electronic	Electronic	
	<b>AMG RIDE CONTROL Suspension</b>	Optional	3-stage	3-stage (manually adjustable)	
	<b>AMG DYNAMIC SELECT</b>	Slippery, Comfort, Sport, Sport+, Individual and Manual	Also includes RACE mode	Also includes RACE mode	
	<b>RACE START</b>	N/A	Standard	Standard	
	<b>Rear-Axle Steering</b>	N/A	Standard	Standard	
	<b>Traction control</b>	AMG 3-stage ESP®	AMG 3-stage ESP®	AMG TRACTION CONTROL /w 9 Stages	
	<b>AMG Performance Exhaust</b>	Optional	Standard (2-stage)	Standard (2-stage, Titanium)	
	<b>AMG GT Common Characteristics</b>	<b>AMG SPEEDSHIFT DCT 7-speed Dual Clutch Transmission</b>	X	X	X
		<b>Aluminum Space Frame</b>	X	X	X
<b>Drive Layout</b>		Front/Mid-Engine	Front/Mid-Engine	Front/Mid-Engine	
<b>Handcrafted AMG 4.0-Liter V8 Biturbo</b>		X	X	X	
<b>Dry Sump Lubrication</b>		X	X	X	

## Non-metallic Paints



040  
Black  
Option price: \$0



589  
Jupiter Red  
Option price: \$0

## Metallic Paints



183  
Magnetite Black  
Option price: \$720



775  
Iridium Silver  
Option price: \$720



896  
Brilliant Blue  
Option price: \$720



992  
Selenite Grey  
Option price: \$720

## AMG and designo® Paints



996  
*designo* Cardinal Red  
Option price: \$1,080



799  
*designo* Diamond White  
Option price: \$1,515



297  
*designo* Selenite Grey Magno  
Option price: \$3,950



982  
*designo* Iridium Silver Magno  
Option price: \$3,950



644  
*designo* Brilliant Blue Magno  
Option price: \$3,950



278  
AMG Solarbeam Yellow  
Option price: \$9,900  
GTC & GTR only



376  
AMG Green Hell Magno  
Option price: \$9,900  
GTR only



793  
19" AMG  
Twin 5-Spoke  
R01, B51  
Option price: \$0  
GT only



RXN  
19"/20" AMG  
10-Spoke Y-design  
R01, B51  
Option price: \$1,000  
GT only



765  
19"/20" AMG  
Split 5-Spoke  
R01, B51  
GT: \$1,000  
GT only



663  
19"/20" AMG  
Split 5-Spoke, Black  
R01, B51  
GT: \$1,500  
GT only



RXO  
19"/20" AMG Twin-5-Spoke  
R01, B51  
Option price: \$0  
GT C only



RXP  
19"/20" AMG Twin-5-Spoke  
with Black Accents  
R01, B51  
Option price: \$500  
GT C only



658  
19"/20" AMG  
Forged Cross-Spoke  
R01, B51  
GT: \$1,700, GT C: \$1,200  
GT & GT C only



659  
19"/20" AMG  
Forged Cross-Spoke, Black  
R01, B51  
GT: \$2,200, GT C: \$1,700  
GT & GT C only



RXQ  
19"/20" AMG  
Forged Split 10-Spoke  
R01, B51  
*Option price: \$1,200*  
*GTC only*



RXR  
19"/20" AMG Forged Split 10-  
Spoke, Black  
R01, B51  
*Option price: \$1,700*  
*GTC only*



RXA  
19"/20" AMG  
Forged 10-Spoke  
R03, B51  
*Option price: \$0*  
*GTR only*



RXB  
19"/20" AMG  
Forged 10-Spoke, Black  
R03, B51  
*Option price: \$500*  
*GTR only*



RXC  
19"/20" AMG Performance  
Forged Twin 5-Spoke, Black  
R03, B51  
*Option price: \$1,700*  
*GTR only*



RXE  
19"/20" AMG Performance  
Forged Twin 5-Spoke  
Grey  
R03, B51  
*GTR PRO only*

<i>Code</i>	<i>Wheel Size</i>	<i>Description</i>	<i>Wheel Dimensions</i>	<i>Mobility</i>	<i>Availability</i>	<i>MSRP</i>
793	19"	AMG Twin 5-Spoke Wheels	255/35 R 19 on 9 J (Front) 295/30 R 19 on 11 J (Rear)	R01, B51	GT	\$ 0
RXN	19"/20"	AMG 10-Spoke Y-design Wheels	265/35 R 19 on 9 J (Front) 295/30 R 20 on 11 J (Rear)	R01, B51	GT	\$ 1,700
765	19"/20"	AMG Split 5-Spoke Wheels	265/35 R 19 on 9 J (Front) 295/30 R 20 on 11 J (Rear)	R01, B51	GT	\$ 1,000
663	19"/20"	AMG Split 5-Spoke Black Wheels	265/35 R 19 on 9 J (Front) 295/30 R 20 on 11 J (Rear)	R01, B51	GT	\$ 1,500
RXO	19"/20"	AMG Twin-5-Spoke	265/35 R 19 on 9 J (Front) 305/30 R 20 on 12 J (Rear)	R01, B51	GTC	\$ 0
RXP	19"/20"	AMG Twin-5-Spoke, Black	265/35 R 19 on 9 J (Front) 305/30 R 20 on 12 J (Rear)	R01, B51	GTC	\$ 500
658	19"/20"	AMG Forged Cross-Spoke Wheels	265/35 R 19 on 9 J (Front) 295/30 R 20 on 11 J (Rear - GT) 305/30 R 20 on 12 J (Rear - GT C)	R01, B51	GT GT C	\$ 1,700 \$ 1,500
659	19"/20"	AMG Forged Cross-Spoke Wheels in Black	265/35 R 19 on 9 J (Front) 295/30 R 20 on 11 J (Rear - GT) 305/30 R 20 on 12 J (Rear - GT C)	R01, B51	GT GT C	\$ 2,200 \$ 1,700
RXQ	19"/20"	AMG Forged Split 10-Spoke Wheels	265/35 R 19 on 9 J (Front) 305/30 R 20 on 12 J (Rear)	R01, B51	GTC	\$ 1,200
RXR	19"/20"	AMG Forged Split 10-Spoke Wheels in Black	265/35 R 19 on 9 J (Front) 305/30 R 20 on 12 J (Rear)	R01, B51	GTC	\$ 1,700

<i>Code</i>	<i>Wheel Size</i>	<i>Description</i>	<i>Wheel Dimensions</i>	<i>Mobility</i>	<i>Availability</i>	<i>MSRP</i>
RXA	19"/20"	AMG Forged 10-Spoke Wheels	275/35 ZR19 on 10 J (Front) 325/30 ZR20 on 12 J (Rear)	R03, B51	GTR	\$ 0
RXB	19"/20"	AMG Forged 10-Spoke Wheels in Black	275/35 ZR19 on 10 J (Front) 325/30 ZR20 on 12 J (Rear)	R03, B51	GTR	\$ 500
RXC	19"/20"	AMG Performance Forged Twin 5-Spoke Wheels in Black	275/35 ZR19 on 10 J (Front) 325/30 ZR20 on 12 J (Rear)	R03, B51	GTR	\$ 1,700
RXE	19"/20"	AMG Performance Forged Twin 5-Spoke Wheels in Grey	275/35 ZR19 on 10 J (Front) 325/30 ZR20 on 12 J (Rear)	R03, B51	GTR PRO	



641

Black MB-TEX/DINAMICA

*Option Price for GT: \$0 (GT only)*

*Not Available with 401 Ventilated Front Seats*

# Interior Upholstery – Nappa Leather



801  
Black  
*Option Price for GT: \$1,900*  
*GT only*



804  
Auburn Brown  
*Option Price for GT: \$1,900*  
*GT only*



857  
Red Pepper/Black  
*Option Price for GT: \$1,900*  
*GT only*



858  
Silver Pearl/Black  
*Option Price for GT: \$1,900*  
*GT only*





661

Black Nappa/DINAMICA

*Option Price for GT R: \$0*

*GT R only*

*Not Available with 401 Ventilated Front Seats*

# Interior Upholstery – Exclusive Nappa Leather w/Diamond Stitching



501  
Black

Option Price for GT C: \$0



555  
Platinum White/Black  
Option Price for GT C: \$0



558  
Silver Pearl/Black  
Option Price for GT C: \$0



504  
Auburn Brown  
Option Price for GT C: \$0



557  
Red Pepper/Black  
Option Price for GT C: \$0

# Interior Upholstery – Exclusive Nappa Leather w/Diamond Stitching



564

Saddle Brown

*w/ Diamond Stitching*

*Option Price for GT C: \$0*



565

Macchiato Beige/Black

*w/ Diamond Stitching*

*Option Price for GT C: \$0*



568

Silver Pearl/Black

*w/ Diamond Stitching*

*Option Price for GT C: \$0*

# Interior Upholstery – Exclusive Nappa Leather/DINAMICA



601

Black w/ Yellow Topstitching  
Option Price for GT C: \$1,200



631

Black w/ Red Accents & Red Topstitching  
Option Price for GT C: \$1,200



621 (GT C Code)

Black w/ Silver Accents & Silver Topstitching  
Option Price for GT C: \$1,200



621 (GT R Code)

Black w/ Silver Accents & Silver Topstitching  
Option Price for GT R: \$3,600  
GT R only  
Requires 318 Exclusive Interior Package



651

Black w/ Yellow Topstitching  
Option Price for GTR: \$3,600  
GT R only  
Requires 318 Exclusive Interior Package

**PM Note for DINAMICA Upholstery:**

*Selection of a DINAMICA upholstery will delete 401 Ventilated Front Seats. This is because DINAMICA upholstery does not have perforations.*

<i>Code</i>	<i>Upholstery</i>	<i>Seats</i>	<i>Floor Mats</i>	<i>Upper Dash/Lower Dash</i>	<i>Headliner</i>	<i>Topstitching</i>
641	Black MB-Tex w/ DINAMICA	Black	Black	Black	Black	None
801	Black Nappa leather	Black	Black	Black	Black	None
804	Auburn Brown Nappa leather	Auburn Brown	Black	Black	Black	None
857	Red Pepper/Black Nappa leather	Black/Red Pepper	Black	Black	Black	None
858	Silver Pearl/Black Nappa leather	Black/Silver Pearl	Black	Black	Black	None
661	Black Nappa/DINAMICA leather	Black	Black	Black	Black	None
501	Black Exclusive Nappa leather	Black	Black	Black	Black	None
555	Platinum White/Black Nappa leather	Platinum White/Black	Black	Black/Platinum White	Black	None
558	Silver Pearl/Black Nappa leather	Silver Pearl/Black	Black	Black/Silver Pearl	Black	None
504	Auburn Brown Nappa leather	Auburn Brown	Black	Black/Auburn Brown	Black	None
557	Red Pepper/Black Nappa leather	Red Pepper/Black	Black	Black/Red Pepper	Black	None
564	Saddle Brown Nappa leather	Saddle Brown	Black	Black/Saddle Brown	Black	None
565	Macchiato Beige/Black Nappa leather	Macchiato Beige	Macchiato Beige	Black/Macchiato Beige	Beige	None
568	Silver Pearl/Black Nappa leather	Black/Silver Pearl	Black	Black	Black	None
601	Black Nappa leather/DINAMICA	Black	Black	Black	Black	Yellow
621	Black Nappa leather/DINAMICA w/ Silver Accents	Black	Black	Black	Black	Silver
631	Black Nappa leather/DINAMICA w/ Red Accents	Black	Black	Black	Black	Red
661	Black Nappa leather/DINAMICA	Black	Black	Black	Black	None
651	Black Nappa leather/DINAMICA	Black	Black	Black	Black	Yellow

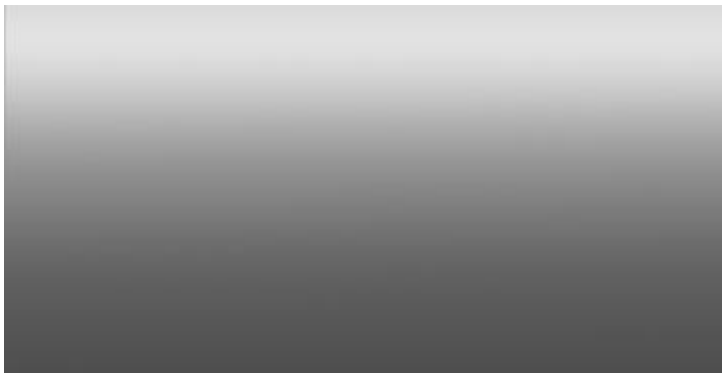

H70

AMG Silver Chrome trim

*Option Price for GT & GT C: \$0*

*GT & GT C only*



H21

AMG Black Piano Lacquer trim

*Option Price for GT & GT C: \$750, GT R: \$0*

*May be combined with PAK AMG Interior Night Package*

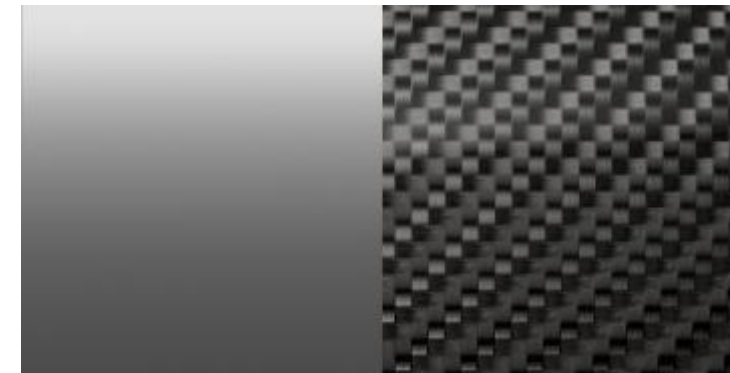

H73

AMG Gloss carbon fiber trim

*Option Price for GT C: \$2,850*

*GT C only*

*Requires 735 Exclusive Trim Package*

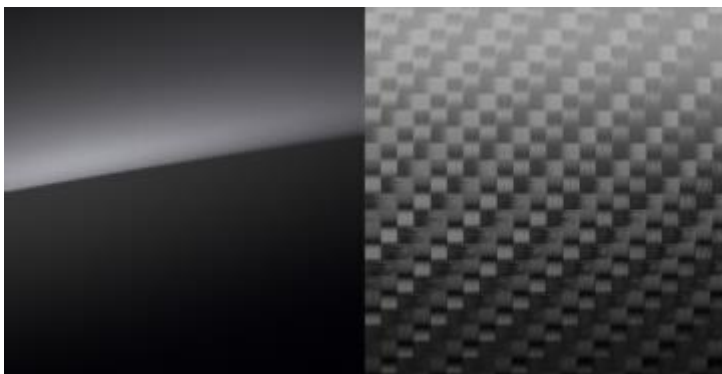

H77

AMG Matte carbon fiber trim

*Option Price for GT C & GT R: \$3,150*

*GT C & GTR only*

*Requires 735 Exclusive Trim Package*

*May be combined with PAK AMG Interior Night*

<i>Code</i>	<i>Packages</i>	<i>Availability</i>	<i>MSRP</i>
DA7	<b>Lane Tracking Package</b> <ul style="list-style-type: none"> <li>▪ 234 - Blind Spot Assist</li> <li>▪ 476 - Lane Keeping Assist</li> </ul>	GT, GT R <i>Standard on GT C</i>	\$ 875
DA8	<b>KEYLESS-GO</b> <ul style="list-style-type: none"> <li>▪ 889 - KEYLESS-GO</li> <li>▪ 871 - Power Trunk Release <i>(Except with 773 selected)</i></li> </ul>	GT	\$ 800
DC3	<b>AMG Aerodynamic Package</b> <i>Not compatible with 773 Exterior Carbon Fiber Package</i> <i>Note: Combining P60 AMG Exterior Night Styling Package and B26 is a recommended combination</i> <ul style="list-style-type: none"> <li>▪ B26 - including more aggressive front splitter and air intake flics</li> <li>▪ U94 - Fixed Rear Spoiler</li> </ul>	GT, GT C	\$ 2,850
DB1	<b>Exclusive Interior Package</b> <i>Required for Exclusive Nappa Leather 5xx and Exclusive Nappa/DINAMICA 6xx Leather Interiors.</i> <ul style="list-style-type: none"> <li>▪ 61U - Black DINAMICA Headliner</li> <li>▪ 877 - Extended Interior Lighting</li> </ul>	GTR	\$ 3,600
DA1	<b>Convenience Package</b> <ul style="list-style-type: none"> <li>▪ P49 - Mirror Package - Power/Memory/Dimming/Folding mirrors</li> <li>▪ 232 - Garage Door Opener</li> <li>▪ P17 - KEYLESS-GO</li> </ul>	GTR	\$ 1,300

<i>Code</i>	<i>Packages</i>	<i>Availability</i>	<i>MSRP</i>
DE7	<b>AMG Exterior Carbon Fiber Package I</b> <i>GT C Description:</i> Not with B26 or P60 Carbon fiber elements: Front splitter, fins in front fenders, rear diffuser, side view mirror housings Gloss black elements: Grille lamelle, side window trim	GT C	\$ 5,300
	 <i>GT R Description:</i> Carbon fiber elements: Front splitter, fins in front fenders, lateral side skirt inserts, rear diffuser	GT R	\$ 5,300
DC4PKG	<b>AMG Exterior Carbon Fiber Package II</b> Carbon fiber elements: Fixed rear wing incl. lateral end plates, side view mirror housings (B28)	GT R	\$ 4,000



# Stand-Alone Options

<i>Code</i>	<i>Options</i>	<i>Availability</i>	<i>MSRP</i>
C52	Fitted indoor car cover	All Models	\$ 370
Y04	Silver seat belts	All Models	\$ 500
Y05	Red seat belts	All Models	\$ 500
Y06	Yellow seat belts	GTR	\$ 500
B29	AMG Carbon fiber door sill covers <i>Not available with U25 AMG Illuminated door sill covers</i>	All Models	\$ 1,200
239	Active Distance Assist DISTRONIC	All Models	\$ 2,250
446	Touchpad Only option (replaces control knob on center console) <i>*This option deletes Android Auto capabilities</i>	All Models	\$ 0
479	AMG RIDE CONTROL Sport Suspension with 3-stage adjustment	GT	\$ 1,500
416	Fixed Panorama Roof	GT	\$ 1,250
401	Heated and Ventilated front seats <i>Not available with 6xx-Upholstery containing DINAMICA</i>	GT	\$ 450
P60	AMG Exterior Night Package <i>Cannot be combined with DE7 Carbon Fiber Package I</i>	GT, GT C	\$ 750
U25	AMG Illuminated door sill covers <i>Not available with B29 AMG Carbon fiber door sill covers</i>	GT, GT R	\$ 700
PAK	AMG Interior Night Package <i>Only with H21 &amp; H77 Interior Trims, L6G AMG Full DINAMICA Steering Wheel</i>	GT C	\$ 800
R03	Extreme-Performance Sport Tires (Michelin® Pilot Sport Cup 2)	GT C	\$ 600

<i>Code</i>	<i>Options</i>	<i>Availability</i>	<i>MSRP</i>
B14	AMG Carbon fiber engine cover	GT C	\$ 1,500
5U8	Crossbar – Carbon fiber – Gloss	GT C	\$ 1,600
5U9	Crossbar – Carbon fiber – Matte	GT C & GTR	\$ 1,600
735	Exclusive Trim Control Code <i>Required for 5XX, 601, 621, 631, 651 Upholsteries</i>	GT C & GT R	\$ 0
810	Burmester® Surround Sound System	GT & GTR	\$ 1,300
811	Burmester® High-End 3D Surround Sound System	GT C & GTR	\$ 4,500
B07	AMG High-Performance Ceramic Composite Braking System	GT C & GT R	\$ 8,950
U70	Red brake caliper <i>replaces Yellow Brake Caliper on AMG High-Performance Braking System</i>	GTR	\$ 0

## *Controller Knob vs Touchpad Only*



**Standard Controller Knob**



**446 – Touchpad Only**

## Steering Wheels



### **L6J – AMG Performance steering wheel – Full Nappa**

*Standard on GT*

*Option Price for GT C: \$0*

*GT & GT C only*

*Not compatible w. 601, 621, 631, PAK*

- flattened bottom section
- perforated grip areas
- silver-colored aluminum shift paddles
- 12-o'clock marking.



### **L6H - AMG Performance Steering Wheel – Carbon Fiber/DINAMICA**

*Option Price for GT: \$900, GT C: \$300*

*Only with H21 or H73 Trim*

*Not compatible with PAK*

*GT and GT C Only*

- flattened bottom section
- Side grips finished in DINAMICA microfiber
- silver-colored aluminum shift paddles
- 12-o'clock marking



### **L6G – AMG Performance steering wheel – Full DINAMICA**

*Standard on GT C & GTR*

*Steering Wheel included with PAK AMG Interior Night Package*

- flattened bottom section
- fully trimmed in DINAMICA microfiber
- silver-colored aluminum shift paddles
- 12-o'clock marking

## *Steering Wheels*



### **L6L - AMG Performance Steering Wheel – Nappa/Black Piano Lacquer**

*Option Price for GT: \$600, GT C: \$0*

*Only with H21 or H77 Trim*

*Not compatible with PAK*

*GT and GT C Only*

- flattened bottom section
- perforated grip areas
- silver-colored aluminum shift paddles
- 12-o'clock marking.

## Brakes



### **AMG High-Performance Braking System (B06)**

*Standard on GT (GT only)*

- Front axle: 14.2" front brake discs, internally ventilated and perforated with 6-piston fixed calipers
- Rear axle: 14.2" rear brake discs, internally ventilated and perforated with single-piston floating caliper
- Anodised silver-color finish



### **AMG High-Performance Composite Braking System (U70)**

*Standard on GT C*

*Option price for GT R: \$0*

- Front axle: 15.4" front brake discs, internally ventilated and perforated with 6-piston fixed calipers
- Rear axle: 14.2" rear brake discs, internally ventilated and perforated with single-piston floating caliper
- Red-painted brake calipers



### **AMG High-Performance Composite Braking System (U69)**

*Standard on GT R (GTR only)*

- Front axle: 15.4" front brake discs, internally ventilated and perforated with 6-piston fixed calipers
- Rear axle: 14.2" rear brake discs, internally ventilated and perforated with single-piston floating caliper
- The brake calipers painted in a yellow color with AMG logo convey a sense of value and sportiness
- Yellow-painted brake colors



### **AMG High-Performance Ceramic Composite Braking System (B07)**

*Option Price for GT C & GTR: \$8,950*

- Front axle: 15.8" front brake discs, internally ventilated and perforated with 6-piston fixed calipers
- Rear axle: 14.2" rear brake discs, internally ventilated and perforated with single-piston floating caliper
- Weight reduction of 40% compared with conventional steel brake discs
- Signature Bronze-painted brake calipers

## *Sound Systems*



### **Loudspeaker – 4**

*Standard on GT & GTR*

- 100 W output
- Tone controls (bass, treble, fader, balance)
- Separate audio/telephone volume control
- Lowest weight of all available sound systems



### **810 Burmester® Surround Sound System**

*Option Price for GT & GTR: \$1,300, Std. on GT C*

- 10 high-performance speakers, including subwoofer in rear, precisely tailored to the vehicle interior to ensure well-balanced and very dynamic music reproduction
- 10-channel DSP amplifier with a total output power of 640 watts for optimum sound quality
- Combination of digital and analogue filter elements for that unique Burmester "feel-good sound"
- Noise compensation (VNC)
- Support for common multi-channel formats, e.g. Dolby Digital 5.1/DTS for genuine surround sound



### **811 Burmester® High-End Surround Sound System**

*Option Price GT C & GTR: \$4,500*

- 11 high-performance loudspeakers including subwoofer
- 11-channel amplifier with active crossover and a system output of 1000 watts
- Active analogue filters
- VIP seat function to optimize the sound for driver or pass.
- Noise compensation (VNC)
- 4 sound presets to enhance the listening experience: Pure, Easy Listening, Live, Surround
- Support for common multi-channel formats, e.g. Dolby Digital 5.1/DTS for genuine surround sound

## *AMG DYNAMIC PLUS Package (P71)*



L6G - AMG Performance steering wheel – Full DINAMICA

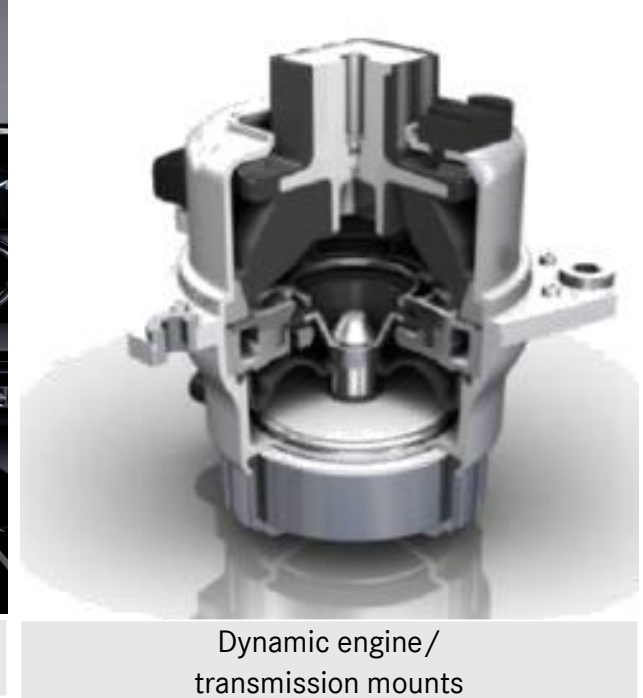

Dynamic engine/  
transmission mounts

### **AMG DYNAMIC PLUS Package (P71)**

*Standard on GT C & GTR (N/A on GT)*

Content:

- Enhanced suspension profile
- Enhanced steering profile
- Increased negative camber



## AMG Night Styling (P60)



Front splitter in gloss black	Grille in gloss black	Side fins in gloss black	Side window trim in gloss black	Side view mirror housings in gloss black	Tailpipes in black chrome	Rear apron trim in gloss black
-------------------------------	-----------------------	--------------------------	---------------------------------	--	---------------------------	--------------------------------

### **AMG Night Styling (P60)**

*Option Price: \$750*

*GT & GT C only*

*NOTE: Cannot be combined with:773 - Exterior Carbon Fiber Package*

*This package is compatible with B26 AMG Aerodynamic Package.*

## AMG Aerodynamic Package (DC3)



Enhanced matte black front splitter

Matte black air intake flics

Matte black front wheel arch flics

Matte black side sill extensions



High-gloss black Fixed Rear Spoiler

### **AMG Aerodynamic Package (DC3)**

*Option Price: \$2,850*

*GT & GT C only*

*NOTES: Cannot be combined with DE7 – AMG Exterior Carbon Fiber Package.*

*Product Management recommends combining with with: P60 – AMG Night Styling.*

## AMG Carbon Fiber Package I (DE7)



Front Splitter in Carbon Fiber

Side Fins in Carbon Fiber

Side Window Trim in Gloss Black

Side View Mirror Housings in Carbon Fiber



Rear Apron Insert in Carbon Fiber

### **! AMG Carbon Fiber Exterior Trim (DE7)**

Option Price: \$5,300 (GT C) or \$5,250 (GT R)

GT C & GT R only

NOTES: Cannot be combined with P60 – AMG Night Styling, DC3 – AMG Aerodynamic Package.

Deletes 871 Hands Free Trunk Access.

## *AMG Exterior Carbon Fiber Package II (DC4)*



### **AMG Exterior Carbon Fiber Package II (DC4)**

Option Price: \$4,000

GT R only

## *PAK – AMG Interior Night Package*



### **PAK – AMG Interior Night Package**

***Compatible with H21 and H77 Interior Trims, L6G Steering Wheel Only  
GT C (Optional), GT R (Standard)***

*Option Price (GT C): \$800*

The following elements are finished in black or high-gloss black:

- Door sill with AMG lettering illuminated in white
- Steering wheel spokes
- Steering wheel bezel
- Steering wheel gearshift paddles
- Seat insert beneath the head restraints
- Luggage compartment strut

## AMG Carbon Fiber Engine Cover (B14)



**AMG carbon fiber engine cover (B14)**

*Option Price: \$1,500*

*GT C only*

*NOTE: Standard on GT R*

## Fixed Panorama Roof (416)

---



### **Fixed Panorama roof (416)**

*Option Price: \$1,260*

*GT only*

*Standard on GT C*

*Fixed Panorama Roof (does not open) - Includes Roller Shade. NOTE: Aluminum Roof - Standard.*

## Seat Belts (Y04/Y05/Y06)



Y04 - Silver seat belts

### **Seat belts (Y04)**

*Option Price: \$500*

*Black Seat Belts Are Standard For All Interiors.*



Y05 - Red seat belts

### **Seat belts (Y05)**

*Option Price: \$500*

*Black Seat Belts Are Standard For All Interiors.*

*PM NOTE: Y05 does not coordinate with Red Pepper Interior Upholstery*

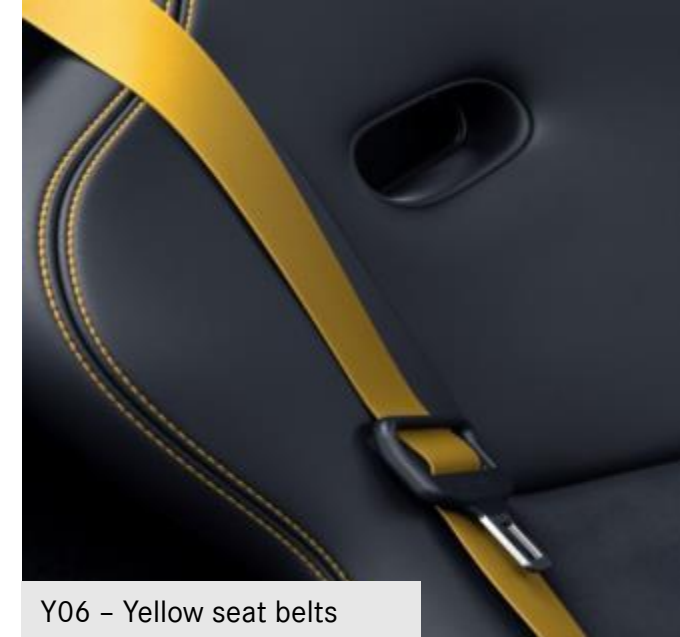

Y06 - Yellow seat belts

### **Seat belts (Y06)**

*Option Price: \$500 (GTR only)*

*Black Seat Belts Are Standard For All Interiors.*



## *Door Sill Covers*



### **AMG stainless steel door sill covers**

*Option Price: \$0*

*NOTE: Becomes black stainless steel with PAK AMG Interior Night Package*



### **U25 - AMG illuminated door sill covers**

*Option Price: \$700*

*Standard on GT C*

*NOTE: Becomes black stainless steel with PAK AMG Interior Night Package*



### **B29 - AMG carbon fiber door sill**

*Option Price: Covers, \$1,200*

## *GT R PRO Exterior*



U15 – edition stripes will be light green when combined with Selenite Grey Magno, and Matte Dark Grey when combined with all other colors. Stripes can be deleted with Omission code U03



Edition Specific RXE wheels are the RXC GT R wheels painted Grey

## *GT R PRO Stripes*



U15 - edition stripes will be light green when combined with Selenite Grey Magno, and Matte Dark Grey when combined with all other colors. Stripes can be deleted with Omission code U03

## *GT R PRO Details*

The new limited-edition AMG GT R PRO is characterized by further improved driving dynamics, in particular on the racetrack. Experience gained from the AMG GT3 and AMG GT4 racing cars was influential in its development, and no other current production Mercedes-AMG is as close to motor racing as the new AMG GT R PRO.

- The new AMG coil-over suspension offers even more choice for tailoring the set-up to the particular track. As in professional motorsport, the driver is not only able to set the spring preload length mechanically, but can now also adjust the compression and rebound of the dampers. This is done quickly and precisely without tools via a click system with an integrated adjustment dial on the damper.
- The AMG GT R is already fitted with Uniball spherical bearings at the lower wishbones of the rear axle. The AMG GT R PRO now gets these bearings also for the upper wishbones. They are significantly more wear-resistant than conventional wishbone bearings and due to their design have no play, which means toe-in and camber do not change even under high loads. As a result, the AMG GT R PRO can be driven with even more precision.
- In addition to a host of carbon-fiber components, weight is saved by making the ceramic composite high-performance braking system standard. And exclusively for the AMG GT R PRO, the brake calipers will be painted black with white lettering.
- Aerodynamic fine-tuning increases the overall performance of the AMG GT R PRO as well. The redesigned front apron was fitted with two flics at the sides made of clear-coated carbon fiber. The lower flics transition virtually seamlessly into the front splitter, which was extended further forward and is held by small metal braces that stabilize the front splitter at higher speeds. The air slots, or gills, in the front fenders effectively vent the wheel arches and contribute to reducing front-axle lift. At the rear, a clear-coated carbon-fiber aero element at the wheel arch on either side rises up vertically almost to the level of the tail lights. The combination of all these measures significantly reduces front-axle lift without negatively impacting the aerodynamic conditions at the rear axle.

- The AMG GT R PRO doesn't only drive like a racing car, it also looks the part. The standard Carbon Fiber Packages I and II with front splitter, fins in the fenders, trim strips in the side sills, side mirrors, rear spoiler, and a diffuser with high-quality clear-coated carbon-fiber finish emphasize the racing inspired design and performance. Additionally, the carbon-fiber roof has been redesigned with a lowered center exclusively for the AMG GT R PRO.
- Even before the world premiere, the new AMG GT R PRO has impressively demonstrated its performance potential on the racetrack: In early November, AMG brand ambassador and AMG GT3 racing driver Maro Engel completed a circuit of the Nürburgring North Loop in exactly 7.04.632 minutes driving a still disguised AMG GT R PRO. This considerably bettered the previous time for the AMG GT R and demonstrated the great potential of the current AMG flagship model.



## *GT R PRO - Additional Photos*



## Handcrafted AMG 4.0L V8 Biturbo engine (M178)



### Handcrafted AMG 4.0-Liter V8 Biturbo engine (M178)

#### Standard

The newly developed AMG 4.0-litre V8 Biturbo engine in the Mercedes-AMG GT combines outstanding performance with ideal weight distribution. It is installed as a front mid-engine behind the front axle and connected to the transmission at the rear axle via the torque tube in a transaxle configuration. The presence of a dry sump lubrication system furthermore results in a significant lowering of the vehicle's center of gravity and greater lateral acceleration.

The most important performance data:

#### GT

- **Output:**

469 hp @ 6,000 rpm

465 lb/ft @ 1,900-5,000rpm

- **Technical Features:**

Dry Sump Lubrication

- **0-60mph:**

3.9 sec

- **Top Speed:**

189 mph (electronically limited)

#### GTC

- **Output:**

550 hp @ 5,750 - 6,750 rpm

502 lb/ft @ 2,100-5,500 rpm

- **Technical Features:**

Dry Sump Lubrication

- **0-60mph:**

3.6 sec

- **Top Speed:**

196 mph (electronically limited)

#### GTR

- **Output:**

577 hp @ 6,250 rpm

516 lb/ft @ 2,100-5,500 rpm

- **Technical Features:**

Dry Sump Lubrication

- **0-60mph:**

3.5 sec

- **Top Speed:**

198 mph (electronically limited)

## AMG SPEEDSHIFT® DCT 7-speed transmission

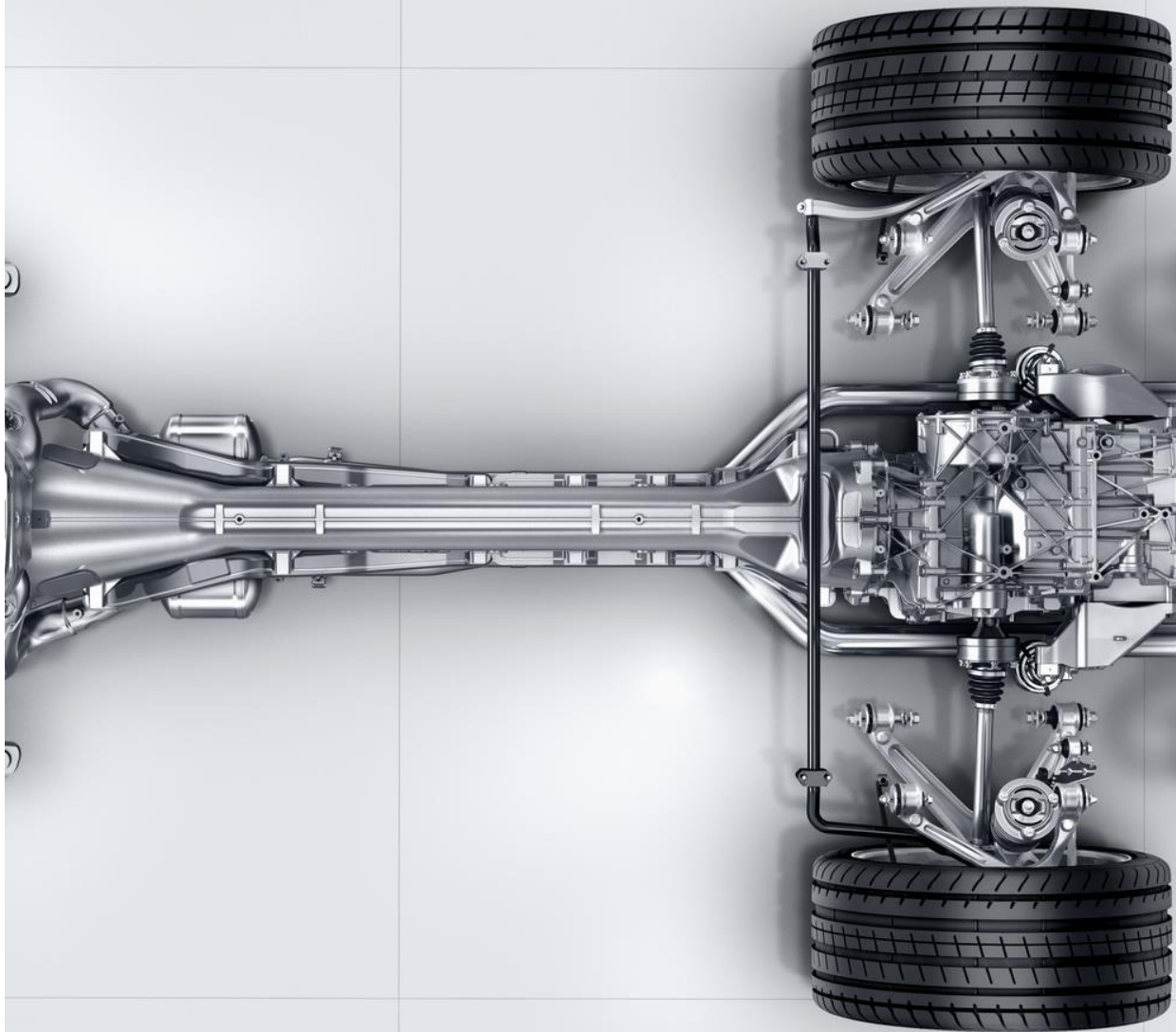

### AMG SPEEDSHIFT® DCT 7-speed transmission

#### Standard

Connected to the engine through the Carbon Fiber driveshaft, itself weighing less than 9lbs., this Dual-clutch transmission boasts spontaneous gear changing and extremely short shift times. 7 gears, 4 or 5\* automatic modes, one manual mode plus double declutching and RACE START\* functions allow exceptionally dynamic acceleration.

- 6 modes selectable using the AMG DYNAMIC SELECT Controller (5 modes for GT)
- Momentary Manual mode: Change to "M" by actuating the shift paddles, will resume to automatic mode after 10 seconds
- When calling on Momentary Manual mode, holding the downshift paddle will place the car in an "optimized downshift" gear, while holding the upshift paddle will place in "highest possible" gear
- The Transaxle transmission is paired to two types of limited-slip differentials, depending on model - with GT featuring a mechanically-actuated version and GT C and GT R featuring electronically-actuated versions with faster detection of variance of wheel speeds
- Partial ignition interruption during upshifts and automatic double-declutching function when downshifting, for emotional exhaust note
- Able to perform 7-3 and 5-2 downshifts cycles when throttle is called upon, with less than 100ms shifts in Sport Plus "S+" and "RACE" modes
- ECO start/stop function and sailing mode in "C" mode

## *AMG Sport Suspension*



### **AMG Sport Suspension**

*Standard on GT (GT only)*

The AMG Sport Suspension delivers impressive roadholding performance thanks to implementation of a double-wishbone design that has proved so successful in AMG motorsports.

Due to this double-wishbone design, the wheel location and suspension functions are entirely separate. Therefore, the driver benefits from stable and harmonious handling performance, even at the limits, thanks to a high level of camber and enough damping in the suspension for quick reflexes in a track setting.

- All 4 wheels are located on double wishbone suspension, with separate control of wheels and springs
- High level of camber and track rigidity: Ensures more precise wheel location and more communicative road feel at the handling limit
- For even more precise roadholding, the spring/damper struts on the rear axle are directly connected to the hub carrier
- Wishbones, steering knuckles and hub carriers made of forged aluminum reduce unsprung weight



## AMG RIDE CONTROL Sport Suspension w/ Variable 3-stage Damping



### **AMG RIDE CONTROL Sport Suspension**

*Optional on GT, Standard on GT C & GTR*

The AMG 3-stage Adaptive Sport Suspension with adaptive adjustable damping provides three different driver-selectable suspension modes. The driver is able to choose between "Comfort", "Sport" and "Sport Plus" at the touch of a button on the center console or by selecting the mode on AMG DYNAMIC SELECT, optimizing the damping characteristics for the current driving situation – from highly comfortable for cruising to sporty for cornering at speed.

The suspension also delivers impressive racetrack performance thanks to implementation of a double-wishbone design that has proved so successful in AMG motorsports.

3 suspension levels: "Comfort", "Sport", "Sport Plus", manually adjustable or selectable by selecting the mode with the AMG DYNAMIC SELECT Controller

Continuously operating damping system enhances driving safety and provides excellent lateral dynamics and driving stability at high speeds.

Damping tuning is controlled individually for each wheel and is dependent on the driving style, the road surface condition and the selected suspension setting.

# Specifications – AMG GT, GT C & GTR

	<i>AMG GT</i>	<i>AMG GT C</i>	<i>AMG GTR</i>
Engine Configuration	Handcrafted AMG 4.0L V8 biturbo with dry-sump lubrication	Handcrafted AMG 4.0L V8 biturbo with dry-sump lubrication	Handcrafted AMG 4.0L V8 biturbo with dry-sump lubrication
Power (hp)	469@6,000	550@5,750-6,750 rpm	577@6.250
Electric Motor (hp)	n/a	n/a	n/a
Torque (lb-ft)	465@ 1,900-5,000 rpm	502@ 2,100-5,500rpm	516@ 2,100-5,500 rpm
Displacement (cc)	3.982	3.982	3.982
Acceleration 0-60mph (sec)	3.9	3.6	3.5
Fuel Economy (Cty/Hwy/Com)	TBD	TBD	TBD
Top Speed (mph)	189	196	198
Fuel Requirement (Octane)	91	91	91
# Valves per cylinder	4	4	4
Compression	10.5 : 1	9.5 : 1	9.5:1
Transmission	AMG SPEEDSHIFT® DCT 7-speed dual-clutch	AMG SPEEDSHIFT® DCT 7-speed dual-clutch	AMG SPEEDSHIFT® DCT 7-speed dual-clutch
Transmission Speeds	7	7	7
Drive Configuration	Rear-Wheel Drive	Rear-Wheel Drive	Rear-Wheel Drive
Standard Tire Type	High-Performance	High-Performance	Michelin® Pilot Sport Cup 2 Tires
Fuel Tank Size (gallons)	19.8	19.8	19.8
Trunk Size (cubic feet)	10.1	10.1	10.1
Curb Weight (lbs)	3,560	3,748	3,594
Vehicle Length (in.)	179	179	179
Vehicle Width w/o mirrors (in.)	76.3	79.0	79.0
Vehicle Width w/ mirrors (in.)	81.7	81.7	81.7
Vehicle Height (in.)	50.7	50.7	50.6
Wheelbase (in.)	103.5	103.5	103.5
Track Width Front/Rear (in.)	66.1/65	66.1/66.1	66.7/66.1
Coefficient of Drag	0.36	0.36	0.35

