

AMG GT R PRO



C190

Model Year 2020

***Pricing TBA, details and content subject to change**

***Photos are Euro Spec**

AMG
DRIVING PERFORMANCE

Important note

The information presented in this guide is based on the most current information available and is intended for internal use only. Mercedes-Benz reserves the right to make changes at any time, without notice, to colors, materials, equipment, special specifications and models.

Pricing may not yet be finalized for some models or options.

Due to variances among monitors and printers the colors that appear on your screen and printouts may not be exact.

For illustrative purposes, some images may show vehicles with European Specification.

Revision History

<i>Date</i>	<i>Changes</i>
12/2018	Initial Release

GT R PRO



Standard Equipment



Exterior Paint Colors



Wheels



Interior Upholstery



Interior Trims



Option Packages



Stand-Alone Options



Options in Detail



Highlights



Specifications

GT R PRO Highlights

Limited-Edition GT R PRO

- Limited to 150 units in the US
- Manually adjustable coil over suspension
- Standard Carbon Ceramic Brakes, Exclusively painted black with white lettering
- Functional “gills” on front fenders
- Larger front splitter with aluminum supports providing greater front axle downforce
- Adjustable Carbon Fiber Sway Bar on front axle
- Exclusive Carbon Fiber Roof
- Standard Matte Carbon Fiber Interior Trim and Crossbar, Carbon Fiber Package I, and Carbon Fiber package II



GT R PRO Details

The new limited-edition AMG GT R PRO is characterized by further improved driving dynamics, in particular on the racetrack. Experience gained from the AMG GT3 and AMG GT4 racing cars was influential in its development, and no other current production Mercedes-AMG is as close to motor racing as the new AMG GT R PRO.

- The new AMG coil-over suspension offers even more choice for tailoring the set-up to the particular track. As in professional motorsport, the driver is not only able to set the spring preload length mechanically, but can now also adjust the compression and rebound of the dampers. This is done quickly and precisely without tools via a click system with an integrated adjustment dial on the damper.
- The AMG GT R is already fitted with Uniball spherical bearings at the lower wishbones of the rear axle. The AMG GT R PRO now gets these bearings also for the upper wishbones. They are significantly more wear-resistant than conventional wishbone bearings and due to their design have no play, which means toe-in and camber do not change even under high loads. As a result, the AMG GT R PRO can be driven with even more precision.
- In addition to a host of carbon-fiber components, weight is saved by making the ceramic composite high-performance braking system standard. And exclusively for the AMG GT R PRO, the brake calipers will be painted black with white lettering.
- Aerodynamic fine-tuning increases the overall performance of the AMG GT R PRO as well. The redesigned front apron was fitted with two flics at the sides made of clear-coated carbon fiber. The lower flics transition virtually seamlessly into the front splitter, which was extended further forward and is held by small metal braces that stabilize the front splitter at higher speeds. The air slots, or gills, in the front fenders effectively vent the wheel arches and contribute to reducing front-axle lift. At the rear, a clear-coated carbon-fiber aero element at the wheel arch on either side rises up vertically almost to the level of the tail lights. The combination of all these measures significantly reduces front-axle lift without negatively impacting the aerodynamic conditions at the rear axle.

- The AMG GT R PRO doesn't only drive like a racing car, it also looks the part. The standard Carbon Fiber Packages I and II with front splitter, fins in the fenders, trim strips in the side sills, side mirrors, rear spoiler, and a diffuser with high-quality clear-coated carbon-fiber finish emphasize the racing inspired design and performance. Additionally, the carbon-fiber roof has been redesigned with a lowered center exclusively for the AMG GT R PRO.
- Even before the world premiere, the new AMG GT R PRO has impressively demonstrated its performance potential on the racetrack: In early November, AMG brand ambassador and AMG GT3 racing driver Maro Engel completed a circuit of the Nürburgring North Loop in exactly 7.04.632 minutes driving a still disguised AMG GT R PRO. This considerably bettered the previous time for the AMG GT R and demonstrated the great potential of the current AMG flagship model.



Performance & Handling

- Handcrafted AMG 4.0L V8 biturbo engine
- AMG SPEEDSHIFT® DCT 7-speed transmission
- AMG High-Performance Ceramic Composite Braking System
- AMG Performance seats
- Next Generation AMG Performance steering wheel
- AMG DYNAMIC SELECT
- 19" / 20" AMG Performance Forged Wheels
- Fixed rear spoiler with PRO specific aluminum brackets
- 9-Mode AMG TRACTION CONTROL
- AMG Coilover Suspension with manual damping adjustment
- Michelin Pilot Sport Cup 2 Tires
- Carbon Fiber Front Fenders with Gills
- Carbon Fiber Packages I & II
- AIRPANEL Active Aerodynamic System for enhanced cooling
- Lower Carbon Fiber aerodynamic profile for enhanced traction
- PRO Specific Front Apron with larger Front Splitter
- Rear Differential, AMG electronic limited-slip
- 15.4" Front & 14.2" Rear brakes with Black-painted brake calipers
- Active rear-axle steering
- PRO Specific Carbon fiber roof with lowered center
- Carbon fiber drive shaft and torque tube
- AMG Performance Exhaust System
- AMG Drive Unit Steering Wheel Buttons
- Adjustable Carbon Fiber Sway Bar on Front Axle
- Adjustable Steel Sway Bar on Rear Axle

Comfort & Convenience

- Power/Heated/Memory AMG Performance seats
- 4-way power steering column
- AMG stainless steel door sill covers
- MercedesMe Connect - with trial period
- Rear load space cover and cargo net
- Trickle charger prewiring (includes accessory trickle charger)
- COMAND® Navigation
- Dual-zone climate control
- AMG Track Pace
- Active LED Headlamps with Intelligent High Beam Control
- AMG Performance steering wheel - Full DINAMICA
- Carbon Fiber Interior Trim - Matte Finish
- Carbon Fiber Crossbar - Matte Finish
- 12.3" fully digital instrument cluster
- 10.25" Multimedia center display
- 4-speaker sound system *(for weight reduction)*

Safety & Security

- Rearview and Front Cameras
- Active Brake Assist
- 8 Standard air bags including driver and passenger knee air bags
- PARKTRONIC®

	Feature	Mercedes-AMG GT R PRO
Optional Features	Bodystyles	Coupe
	Exclusive Nappa Leather	Optional, Nappa/DINAMICA Only
	Lane Tracking Package	Optional (For Weight)
	AMG Dynamic Plus Package	Standard
	AMG High Performance Ceramic Composite Braking System	Standard
Standard Performance Features	Horsepower	577 hp @ 6,250 rpm
	Torque	516 lb.-ft. @ 2,100-5,500 rpm
	Top Speed	198 mph
	Body design	Widebody, Carbon-fiber front fenders
	Active Aerodynamics	AIRPANEL with Carbon Fiber Profile
	Battery	Lithium Ion
	AMG High Performance Ceramic Composite Braking System	15.4" F / 14.2" R, Black Caliper
	AMG Rear Differential Lock	Electronic
	Manually Adjustable Coilover Suspension	6-stage Adjustable Rebound and Compression
	AMG DYNAMIC SELECT	Standard GT R offering with RACE mode
	RACE START	Standard
	Rear-Axle Steering	Standard
	Traction control	AMG TRACTION CONTROL /w 9 Stages
	AMG Performance Exhaust	2-stage, Titanium

<i>Additional Details</i>	<i>AMG GTR PRO</i>
Engine Configuration	Handcrafted AMG 4.0L V8 biturbo with dry-sump lubrication
Displacement (cc)	3.982
Acceleration 0-60mph (sec)	3.5
Fuel Economy (Cty/Hwy/Com)	TBD
Fuel Requirement (Octane)	91
# Valves per cylinder	4
Compression	9.5:1
Transmission	AMG SPEEDSHIFT® DCT 7-speed dual-clutch
Transmission Speeds	7
Drive Configuration	Rear-Wheel Drive
Standard Tire Type	Michelin® Pilot Sport Cup 2 Tires
Fuel Tank Size (gallons)	19.8
Trunk Size (cubic feet)	10.1
Curb Weight (lbs)	TBA
Vehicle Length (in.)	179
Vehicle Width w/o mirrors (in.)	79.0
Vehicle Width w/ mirrors (in.)	81.7
Vehicle Height (in.)	50.6
Wheelbase (in.)	103.5
Track Width Front/Rear (in.)	66.7/66.1
Coefficient of Drag	TBA

Non-metallic Paints

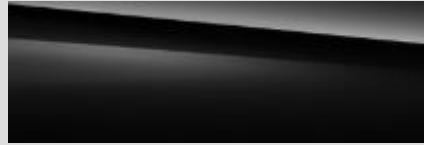

040
Black
Option price: \$0



589
Jupiter Red
Option price: \$0

PRO edition stripes will be Gloss Light Green when combined with Selenite Grey Magno. Stripes will be Matte Dark Grey when combined with all other colors. Stripes can be deleted with Omission code U03.

Metallic Paints



183
Magnetite Black
Option price: \$720



775
Iridium Silver
Option price: \$720



896
Brilliant Blue
Option price: \$720



992
Selenite Grey
Option price: \$720

AMG and designo® Paints



996
designo Cardinal Red
Option price: \$1,080



799
designo Diamond White
Option price: \$1,515



297
designo Selenite Grey Magno
Option price: \$3,950



982
designo Iridium Silver Magno
Option price: \$3,950



644
designo Brilliant Blue Magno
Option price: \$3,950



278
AMG Solarbeam Yellow
Option price: \$9,900



376
AMG Green Hell Magno
Option price: \$9,900



RXC
19"/20" AMG Performance
Forged Twin 5-Spoke, Black
R03, B51

**No Cost Option*

RXE
19"/20" AMG Performance
Forged Twin 5-Spoke, Grey
R03, B51

Standard

<i>Code</i>	<i>Wheel Size</i>	<i>Description</i>	<i>Wheel Dimensions</i>	<i>Mobility</i>	<i>Availability</i>	<i>MSRP</i>
RXC	19"/20"	AMG Performance Forged Twin 5-Spoke Wheels in Black	275/35 ZR19 on 10 J (Front) 325/30 ZR20 on 12 J (Rear)	R03, B51	GTR PRO	No Cost
RXE	19"/20"	AMG Performance Forged Twin 5-Spoke Wheels in Grey	275/35 ZR19 on 10 J (Front) 325/30 ZR20 on 12 J (Rear)	R03, B51	GTR PRO	Std

Interior Upholstery – Nappa Leather/DINAMICA



661

Black Nappa/DINAMICA
Option Price for GT R PRO: \$0



621

Black w/ Silver Accents & Silver Topstitching
Option Price for GT R PRO: \$3,600
Requires 318 Exclusive Interior Package



651

Black w/ Yellow Topstitching
Option Price for GTR PRO: \$3,600
Requires 318 Exclusive Interior Package

<i>Code</i>	<i>Upholstery</i>	<i>Seats</i>	<i>Floor Mats</i>	<i>Upper Dash/Lower Dash</i>	<i>Headliner</i>	<i>Topstitching</i>
661	Black Nappa/DINAMICA leather	Black	Black	Black	Black	None
621	Black Nappa leather/DINAMICA w/ Silver Accents	Black	Black	Black	Black	Silver
651	Black Nappa leather/DINAMICA w/ Yellow Accents	Black	Black	Black	Black	Yellow

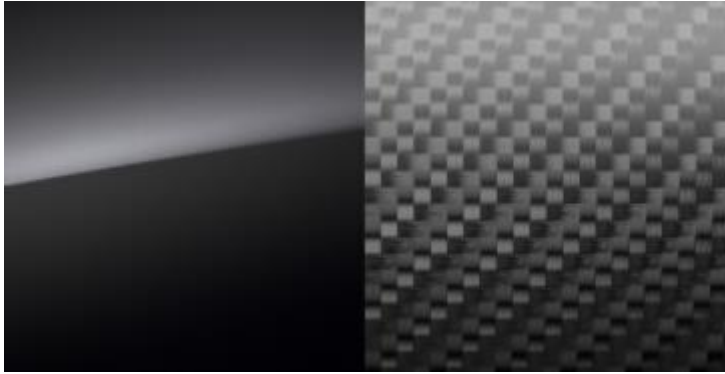

H77
AMG Matte Carbon Fiber Trim
Standard

<i>Code</i>	<i>Packages</i>	<i>Availability</i>	<i>MSRP</i>
DA7PKG	Lane Tracking Package <ul style="list-style-type: none"> ▪ 234 - Blind Spot Assist ▪ 476 - Lane Keeping Assist 	GT R PRO	\$ 875
DB1PKG	Exclusive Interior Package <i>Required for Exclusive Nappa Leather 5xx and Exclusive Nappa/DINAMICA 6xx Leather Interiors.</i> <ul style="list-style-type: none"> ▪ 61U - Black DINAMICA Headliner ▪ 877 - Extended Interior Lighting 	GTR PRO	\$ 3,600
DA1PKG	Convenience Package <ul style="list-style-type: none"> ▪ P49 - Mirror Package - Power/Memory/Dimming/Folding mirrors ▪ 232 - Garage Door Opener ▪ 889 - KEYLESS-GO 	GTR PRO	\$ 1,600
773	AMG Exterior Carbon Fiber Package I Carbon fiber elements: Front splitter, fins in front fenders, lateral side skirt inserts, rear diffuser	GT R PRO	Std
DC4PKG	AMG Exterior Carbon Fiber Package II Carbon fiber elements: Fixed rear wing incl. lateral end plates, side view mirror housings (B28)	GT R PRO	Std

Stand-Alone Options

<i>Code</i>	<i>Options</i>	<i>Availability</i>	<i>MSRP</i>
C52	Fitted indoor car cover	GTR PRO	\$ 370
Y04	Silver seat belts	GTR PRO	\$ 500
Y05	Red seat belts	GTR PRO	\$ 500
Y06	Yellow seat belts	GTR PRO	\$ 500
B29	AMG Carbon fiber door sill covers <i>Not available with U25 AMG Illuminated door sill covers</i>	GTR PRO	\$ 1,200
239	Active Distance Assist DISTRONIC	GTR PRO	\$ 2,250
446	Touchpad Only option (replaces control knob on center console)	GTR PRO	\$ TBA
U25	AMG Illuminated door sill covers <i>Not available with B29 AMG Carbon fiber door sill covers</i>	GT R PRO	\$ 700
R03	Extreme-Performance Sport Tires (Michelin® Pilot Sport Cup 2)	GT R PRO	Std
5U9	Crossbar – Carbon fiber – Matte	GT R PRO	Std
735	Exclusive Trim Control Code <i>Required for 621 and 651 Upholsteries</i>	GT R PRO	\$ 0
810	Burmester® Surround Sound System	GTR PRO	\$ 1,300
811	Burmester® High-End 3D Surround Sound System	GTR PRO	\$ 4,500
B07	AMG High-Performance Ceramic Composite Braking System	GT R PRO	Std

Controller Knob vs Touchpad Only



Standard Controller Knob



446 – Touchpad Only

Steering Wheels



L6G – AMG Performance steering wheel – Full DINAMICA

Standard on GTR PRO

- Flattened bottom section
- Fully trimmed in DINAMICA microfiber
- Black aluminum shift paddles
- 12-o'clock marking

Sound Systems



Loudspeaker – 4

Standard on GTR PRO

- 100 W output
- Tone controls (bass, treble, fader, balance)
- Separate audio/telephone volume control
- Lowest weight of all available sound systems



810 Burmester® Surround Sound System

Option Price for GTR PRO: \$1,300

- 10 high-performance speakers, including subwoofer in rear, precisely tailored to the vehicle interior to ensure well-balanced and very dynamic music reproduction
- 10-channel DSP amplifier with a total output power of 640 watts for optimum sound quality
- Combination of digital and analogue filter elements for that unique Burmester "feel-good sound"
- Noise compensation (VNC)
- Support for common multi-channel formats, e.g. Dolby Digital 5.1/DTS for genuine surround sound



811 Burmester® High-End Surround Sound System

Option Price GTR PRO: \$4,500

- 11 high-performance loudspeakers including subwoofer
- 11-channel amplifier with active crossover and a system output of 1000 watts
- Active analogue filters
- VIP seat function to optimize the sound for driver or pass.
- Noise compensation (VNC)
- 4 sound presets to enhance the listening experience: Pure, Easy Listening, Live, Surround
- Support for common multi-channel formats, e.g. Dolby Digital 5.1/DTS for genuine surround sound

AMG Carbon Fiber Package I (773)



AMG Carbon Fiber Exterior Package I (773)

Standard on GT R PRO

AMG Exterior Carbon Fiber Package II (B28)



AMG Exterior Carbon Fiber Package II (DC4)
Standard on GT R PRO

PAK – AMG Interior Night Package



PAK – AMG Interior Night Package

Standard on GT R PRO

The following elements are finished in black or high-gloss black:

- Steering wheel spokes
- Steering wheel bezel
- Steering wheel gearshift paddles
- Seat insert beneath the head restraints
- Luggage compartment strut

AMG Carbon Fiber Engine Cover (B14)



AMG carbon fiber engine cover (B14)

Standard on GT R PRO



Seat Belts (Y04/Y05/Y06)



Y04 - Silver seat belts

Seat belts (Y04)

Option Price: \$500

Black Seat Belts Are Standard For All Interiors.



Y05 - Red seat belts

Seat belts (Y05)

Option Price: \$500

Black Seat Belts Are Standard For All Interiors.

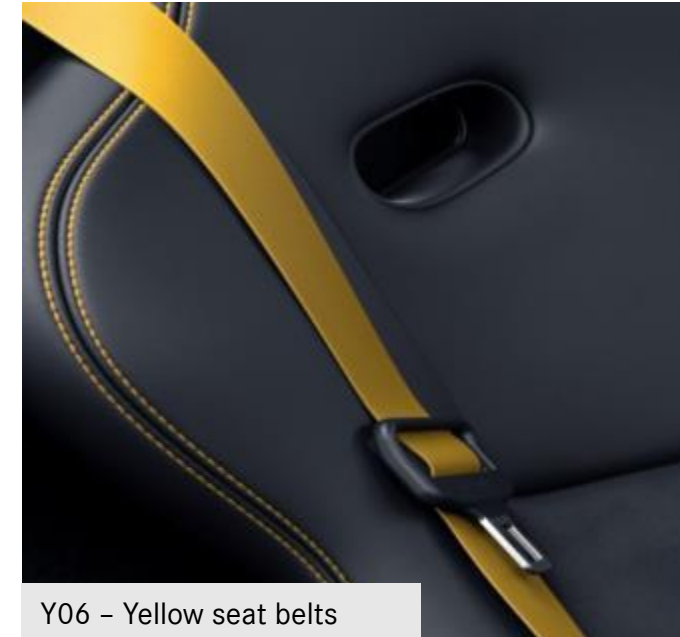

Y06 - Yellow seat belts

Seat belts (Y06)

Option Price: \$500

Black Seat Belts Are Standard For All Interiors.

Door Sill Covers



AMG black stainless steel door sill covers
Standard on GT R PRO



U25 - AMG black illuminated door sill covers
Option Price: \$700



B29 - AMG carbon fiber door sill
Option Price: \$1,200

Handcrafted AMG 4.0L V8 Biturbo engine (M178)



Handcrafted AMG 4.0-Liter V8 Biturbo engine (M178)

Standard

The newly developed AMG 4.0-litre V8 Biturbo engine in the Mercedes-AMG GT combines outstanding performance with ideal weight distribution. It is installed as a front mid-engine behind the front axle and connected to the transmission at the rear axle via the torque tube in a transaxle configuration. The presence of a dry sump lubrication system furthermore results in a significant lowering of the vehicle's center of gravity and greater lateral acceleration.

High level performance data:

GTR PRO

▪ **Output:**

577 hp @ 6,250 rpm

516 lb/ft @ 2,100-5,500 rpm

▪ **Technical Features:**

Dry Sump Lubrication

▪ **0-60mph:**

3.5 sec

▪ **Top Speed:**

198 mph (electronically limited)

AMG SPEEDSHIFT® DCT 7-speed transmission



AMG SPEEDSHIFT® DCT 7-speed transmission

Standard

Connected to the engine through the Carbon Fiber driveshaft, itself weighing less than 9lbs., this Dual-clutch transmission boasts spontaneous gear changing and extremely short shift times. 7 gears, 6 automatic modes, one manual mode plus double declutching and RACE START functions allow exceptionally dynamic acceleration.

- 6 modes selectable using the AMG DYNAMIC SELECT Controller
- Momentary Manual mode: Change to "M" by actuating the shift paddles, will resume to automatic mode after 10 seconds
- When calling on Momentary Manual mode, holding the downshift paddle will place the car in an "optimized downshift" gear, while holding the upshift paddle will place in "highest possible" gear
- The Transaxle transmission is paired to an electronically-actuated limited-slip differential with faster detection of variance of wheel speeds
- Partial ignition interruption during upshifts and automatic double-declutching function when downshifting, for emotional exhaust note
- Able to perform 7-3 and 5-2 downshift cycles when throttle is called upon, with less than 100ms shifts in Sport Plus "S+" and "RACE" modes
- ECO start/stop function and sailing mode in "C" mode

AMG RIDE CONTROL suspension with manual damping adjustment

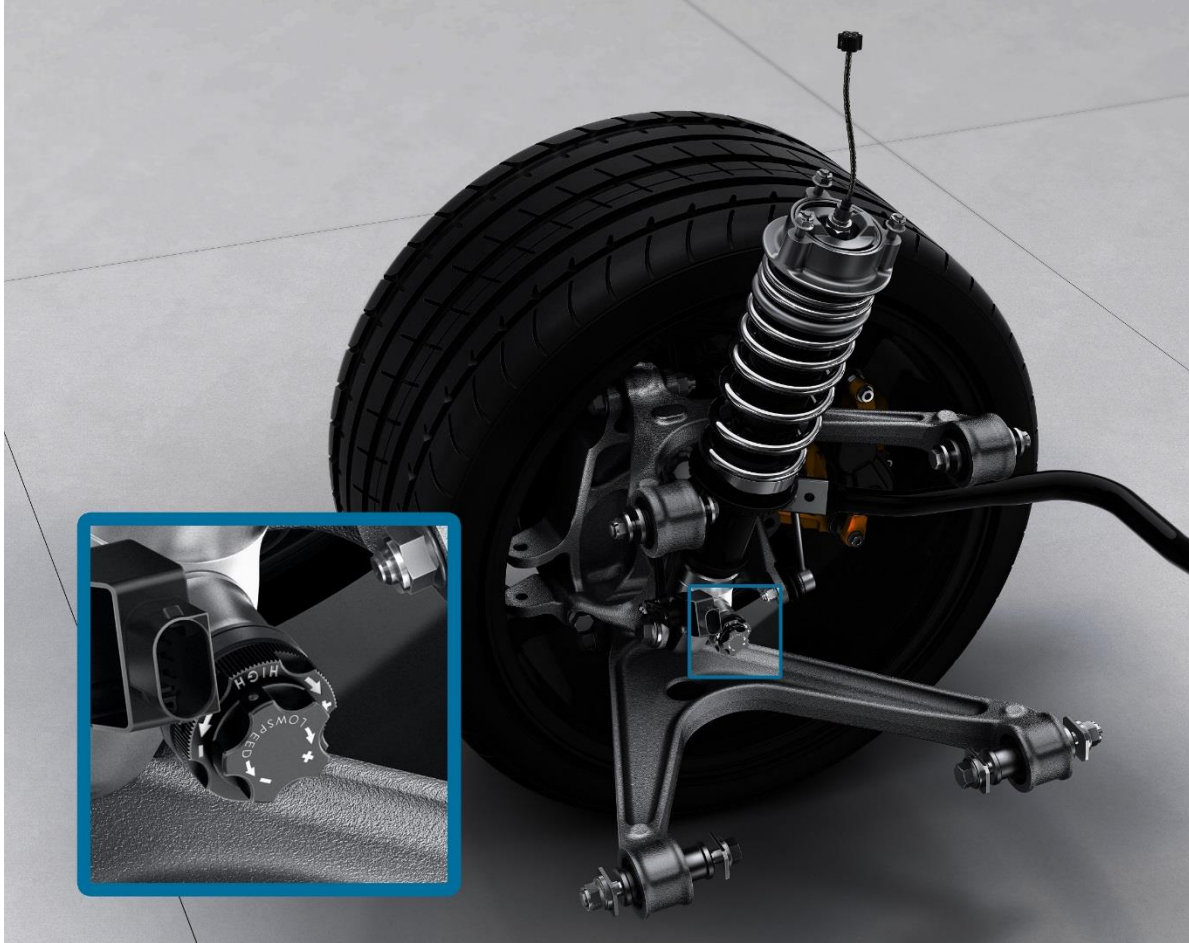

AMG RIDE CONTROL suspension with manual damping adjustment

Standard on GT R PRO

The new AMG RIDE CONTROL suspension with manual damping adjustment and threaded section for the Mercedes-AMG GT R PRO provides even more options for optimum tuning of the setup to suit a particular race track or your personal preferences.

As in professional motorsport, the driver is not only able to manually adjust the spring basis but can now also manually calibrate the rebound and compression stages. This can be carried out quickly and precisely in six stages without tools using a click system with permanently installed adjustment wheels on the damper. This enables the pitch and roll behavior as well as the traction of the Mercedes-AMG GT R PRO to be influenced more precisely.

The AMG RIDE CONTROL suspension with manual damping adjustment and threaded section is reserved exclusively for the Mercedes-AMG GT R PRO. As in professional motorsport, it permits a personally preferred set-up and an ideal configuration for the particular environment. In addition, the threaded section allows a specialist workshop to manually adjust the spring rate.

AMG RIDE CONTROL suspension with manual damping adjustment

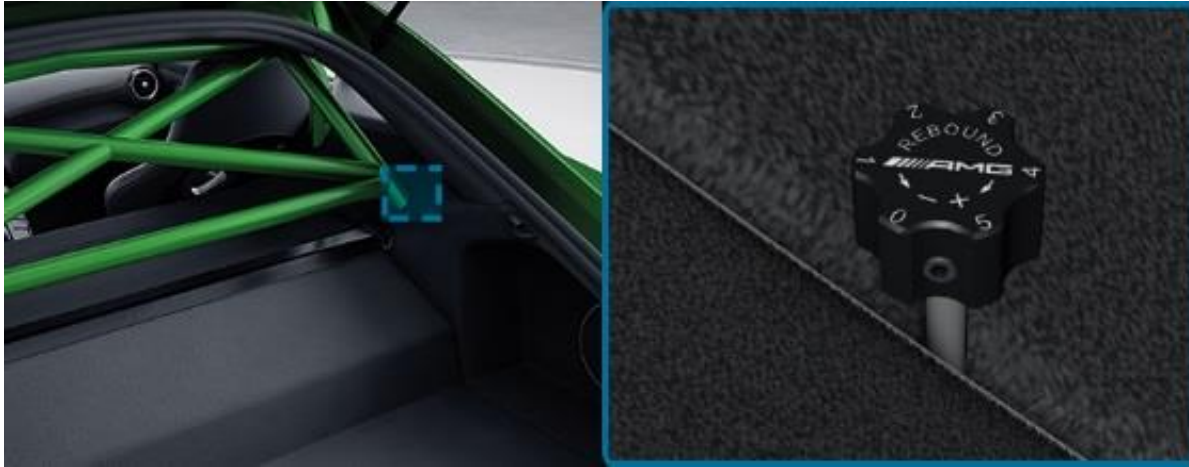

AMG RIDE CONTROL suspension with manual damping adjustment

Standard on GT R PRO

The new AMG RIDE CONTROL suspension with manual damping adjustment and threaded section for the Mercedes-AMG GT R PRO provides even more options for optimum tuning of the setup to suit a particular race track or your personal preferences.

As in professional motorsport, the driver is not only able to manually adjust the spring basis but can now also manually calibrate the rebound and compression stages. This can be carried out quickly and precisely in six stages without tools using a click system with permanently installed adjustment wheels on the damper. This enables the pitch and roll behavior as well as the traction of the Mercedes-AMG GT R PRO to be influenced more precisely.



The AMG RIDE CONTROL suspension with manual damping adjustment and threaded section is reserved exclusively for the Mercedes-AMG GT R PRO. As in professional motorsport, it permits a personally preferred set-up and an ideal configuration for the particular environment. In addition, the threaded section allows a specialist workshop to manually adjust the spring rate.

Adjustable Front and Rear Sway Bars



Adjustable Front and Rear Sway Bars

Standard on GT R PRO

The rear axle is fitted with uniball mounts and the adjustable suspension with lightweight sway bars enable independent customization of the front and rear axles.

- Front Axle: Manually adjustable Carbon Fiber Sway Bar
- Rear Axle: Manually adjustable Steel Sway Bar

Carbon Fiber Shear Panel



Carbon Fiber Shear Panel

Standard on GT R PRO

Near the rear axle you will find a Carbon Fiber shear panel for added rigidity with a minimal impact on weight.

GT R PRO Stripes shown with Selenite Grey Magno



U15 – edition stripes will be light green when combined with Selenite Grey Magno, and Matte Dark Grey when combined with all other colors. Stripes can be deleted with Omission code U03

GT R PRO Stripes shown with Selenite Grey Magno



U15 – edition stripes will be light green when combined with Selenite Grey Magno, and Matte Dark Grey when combined with all other colors. Stripes can be deleted with Omission code U03

GT R PRO Stripes shown with Iridium Silver



U15 – edition stripes will be light green when combined with Selenite Grey Magno, and Matte Dark Grey when combined with all other colors. Stripes can be deleted with Omission code U03

GT R PRO Stripes shown with Iridium Silver



U15 - edition stripes will be light green when combined with Selenite Grey Magno, and Matte Dark Grey when combined with all other colors. Stripes can be deleted with Omission code U03

GT R PRO Exterior



GT R PRO Interior



GT R PRO - Additional Photos

