

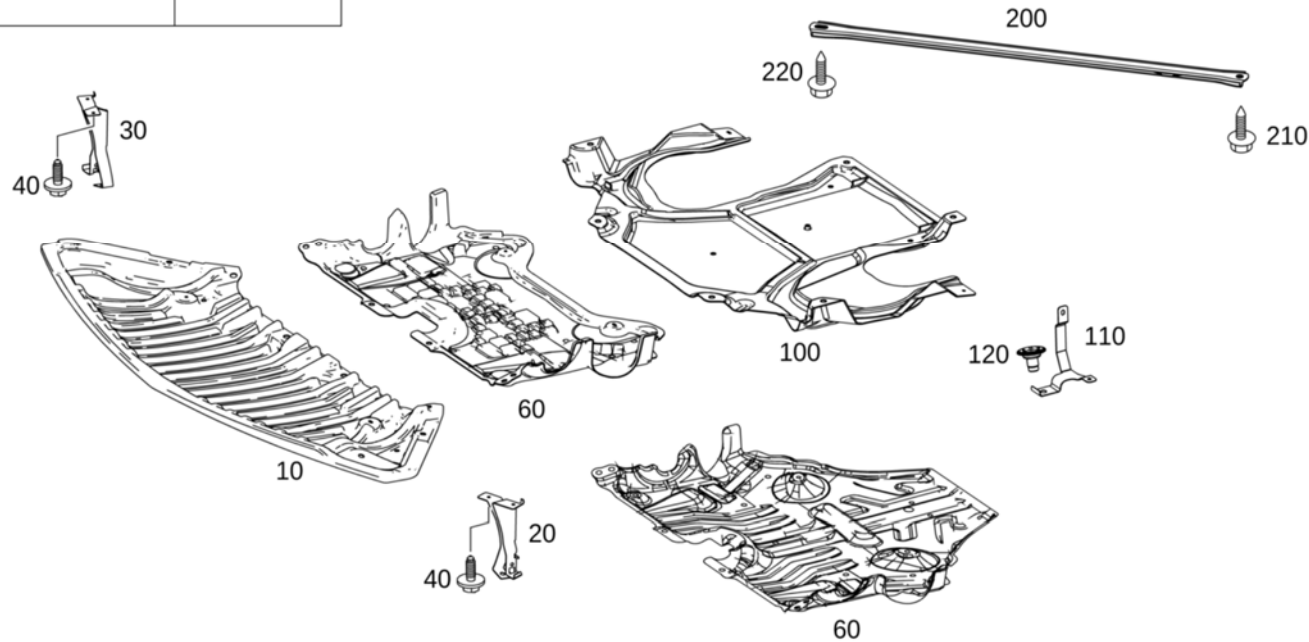

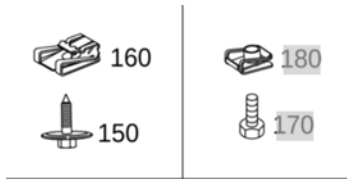









## - Parts list -





<b>Mode</b>	BM mode	<b>Catalog</b>	69B
<b>VIN/mod. des.</b>	WDD2073721F026769	<b>Group</b>	52 CHASSIS SHEET METAL / AIR INTAKE
<b>VIN</b>	WDDKJ7CB5AF026769	<b>Sub-group</b>	030 ENGINE COMPARTMENT PANELLING, GASOLINE VEHICLES
<b>Assortment class</b>	PC		
<b>Market</b>			
<b>BM overview</b>	E 500 / E 550 USA		



Copyright 2020-03-30 Daimler AG

Image ID: drawing\_B52030000456

Item	Part number	Designation/additional information	Qty
10	A 207 524 09 30	<b>COVER, ENGINE COMP. LOWER</b> FRONT  Code: M271/M272/M273/M274/M276+-M005;  Fault location 88355	1
20	A 207 524 01 40	<b>BRACKET</b> LEFT Replaced by: A 207 524 07 40  Plant information	1
20	A 207 524 07 40	<b>BRACKET</b> LEFT Replaces: A2075240140	1
30	A 207 524 02 40	<b>BRACKET</b> RIGHT Replaced by: A 207 524 08 40  Plant information	1
30	A 207 524 08 40	<b>BRACKET</b> RIGHT Replaces: A2075240240	1
40	A 001 990 80 00	<b>COMBI-HEXAGON HEAD BOLT</b>	4
60	A 204 520 28 23	<b>BRACKET LEFT AND RIGHT AT FLEXIBLE CROSSMEMBER; M6X19</b>	
60	A 204 520 28 23	<b>NOISE CAPSULE</b> CENTRAL  Code: M271/M272/M273/M276+-M005/M278;  Fault location 88368	1
100	A 204 524 06 30	<b>COVER, ENGINE COMP. LOWER</b> REAR  Code: M272/M273/M276/M278;  Plant information  Fault location 88356	1
110	A 204 524 25 40	<b>BRACKET</b> LEFT  Code: M651+-060/M271/M273/M274/M276/M278;	1
110	A 204 524 15 40	<b>BRACKET</b> RIGHT  Code: M271/M273/M274/M276+-M005/M278;  Plant information	1
120	A 210 990 01 50	<b>HEXAGON NUT WITH COLLAR</b> BRACKET AT LEFT MAIN FLOOR; 5 MM	2
120	A 210 990 01 50	<b>HEXAGON NUT WITH COLLAR</b> BRACKET AT RIGHT MAIN FLOOR; 5 MM	2

Item	Part number	Designation/additional information	Qty
150	A 001 990 60 36	<b>SHEET METAL SCREW</b> REAR PANEL TO BRACKET; 4.8X19  Code: M271/M272/M273/M274/M276/M278;	2
150	A 001 990 60 36	<b>SHEET METAL SCREW</b> REAR PANEL TO WHEELHOUSE LINER; 4.8X19	2
150	A 001 990 60 36	<b>SHEET METAL SCREW</b> REAR PANEL TO LONGITUDINAL MEMBER; 4.8X19	4
150	A 001 990 60 36	<b>SHEET METAL SCREW</b> FRONT TRIM TO FRAME-TYPE INTEGRALSUPPORT; 4.8X19	2
150	A 001 990 60 36	<b>SHEET METAL SCREW</b> FRONT TRIM TO FRAME-TYPE INTEGRALSUPPORT; 4.8X19	4
150	A 001 990 60 36	<b>SHEET METAL SCREW</b> CENTRAL COVERING TO FRAME-TYPE INTEGRAL SUPPORT; 4.8X19  Code: -M005;	2
150	A 001 990 60 36	<b>SHEET METAL SCREW</b> FRONT TRIM TO BRACKET; 4.8X19	2
150	A 001 990 60 36	<b>SHEET METAL SCREW</b> PANELING FRONT TO WHEELHOUSE PANEL; 4.8X19	2
160	A 004 994 31 45	<b>CLIP NUT</b> REAR PANEL TO BRACKET; 4,8  Code: M271/M272/M273/M274/M276/M278;	2
160	A 004 994 31 45	<b>CLIP NUT</b> REAR PANEL TO WHEELHOUSE LINER; 4,8	2
160	A 001 994 98 45	<b>CLIP NUT</b> REAR PANEL TO LONGITUDINAL MEMBER	4
160	A 004 994 31 45	<b>CLIP NUT</b> FRONT TRIM TO FRAME-TYPE INTEGRALSUPPORT; 4,8	2
160	A 004 994 31 45	<b>CLIP NUT</b> FRONT TRIM TO FRAME-TYPE INTEGRALSUPPORT; 4,8	4
160	A 004 994 31 45	<b>CLIP NUT</b> CENTRAL COVERING TO FRAME-TYPE INTEGRAL SUPPORT; 4,8	2
160	A 004 994 31 45	<b>CLIP NUT</b> FRONT TRIM TO BRACKET; 4,8	2
200	A 204 524 11 47	<b>STRUT</b> BETWEEN LONGITUDINAL MEMBER ANDFRAME-TYPE INTEGRAL SUPPORT  Code: -M005;  Fault location 52A02	2
210	N 000000 005053	<b>HEXAGON HEAD BOLT</b> STRUT TO SIDE MEMBER; M10X20	2

<b>Item</b>	<b>Part number</b>	<b>Designation/additional information</b>	<b>Qty</b>
220	A 001 990 40 03	<b>SCREW WITH FEATURE</b> STRUT TO FRAME-TYPE INTEGRAL SUPPORT	2