

Model 207

Shown on vehicle with ENGINE 272

- 1 Radiator trim
- 2 Bracket
- 3 Left air intake pipe
- 4 Engine hood cable
- 5 Right air intake pipe
- 6 Mounting clip
- 7 Cold air intake bridge

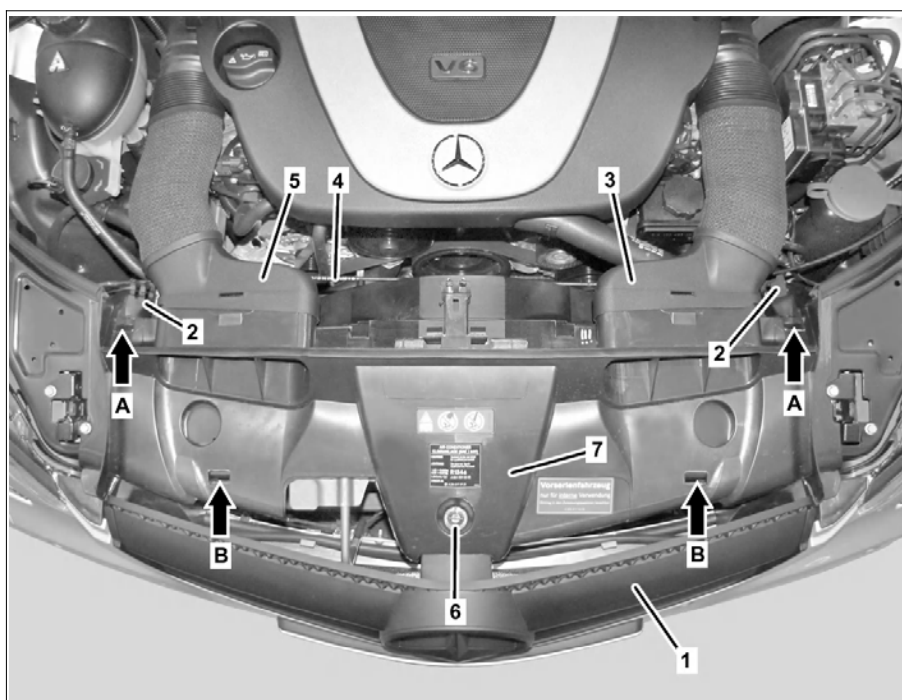

P88.40-2881-06

- 1 Radiator trim
- 8 Front bumper
- 9 Screw

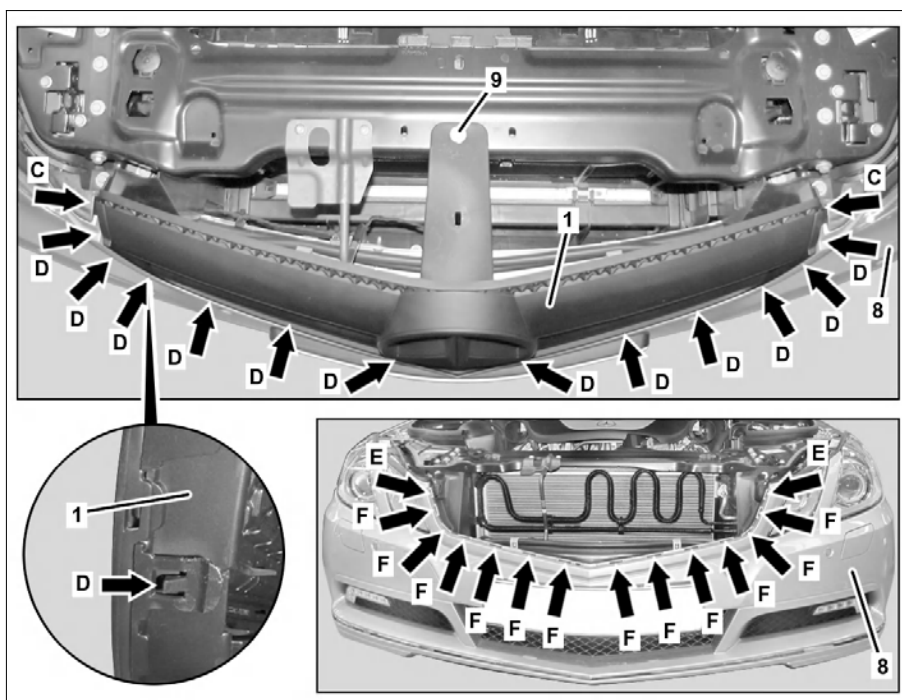

P88.40-2882-06

	Remove/install		
1	Open engine hood		AR88.40-P-1000EW
2	Remove intake air guide from cold air intake bridge (7) to engine cover	Model 207 with engine 642	
3	Remove left air intake pipe (3)	Model 207 with engine 271, 272, 273, 276, 278, 642, 651	
4	Remove right air intake pipe (5)	Model 207 with engine 272, 273, 274, 276, 278, 642	
5	Unhook engine hood cable (4) at holders (2)		
6	Detach retaining clip (6) by turning and remove		

7	Release cold air intake bridge (7) at catch hooks (arrows A and B) and remove		
8	Remove screw/bolt (9)		
9	Disengage catch hooks (arrows C) on radiator trim (1)	<b>i</b> <b>Installation:</b> Ensure that catch hooks (arrows C) are seated correctly in recesses (arrows E) in front bumper (8).	
10	Disengage catch hooks (arrows D) of radiator trim (1) on front bumper (8)	<b>i</b> <b>Installation:</b> Ensure that catch hooks (arrows D) are seated correctly in recesses (arrows F) in front bumper (8).	
11	Expose electrical connector for front 360° camera from radiator trim (1) and disconnect	Model 207 as of 6/1/13 as of model year 2014 with code 501 (360° camera)	AR54.30-P-3001EC
12	Remove radiator trim (1) toward front from front bumper (8)		
13	Install in the reverse order		
14	Calibrate front 360° camera using the diagnostic system	Model 207 as of 6/1/13 as of model year 2014 with code 501 (360° camera)	AD00.00-P-2000-04A
 AD			