

AR35.30-P-0115-01TX	Remove/install and secure rear axle shaft twelve-point collar nut		
---------------------	-------------------------------------------------------------------	--	--

Model 172, 204, 207, 212, 217, 218, 219, 222, 231

Nm Rear axle shaft

Number	Designation		Model 219	
BA35.30-P-1001-01F	Collar nut from rear axle self-locking shaft to rear axle shaft flange	Nm	350	
		not self-locking		
		Stage 1	Nm	170
		Stage 2	∠°	45

Nm Rear axle shaft

Number	Designation		Model 172	Model 204	
BA35.30-P-1001-01J	Collar nut, rear axle shaft to rear axle shaft flange	self-locking	Nm	350	350
		not self-locking			
		Stage 1	Nm	–	170
		Stage 2	∠°	–	45

Nm Rear axle shaft

Number	Designation		Model 207	Model 212	
BA35.30-P-1001-01J	Collar nut, rear axle shaft to rear axle shaft flange	self-locking	Nm	350	350
		not self-locking			
		Stage 1	Nm	170	170
		Stage 2	∠°	45	45

Nm Rear axle shaft

Number	Designation		Model 218	Model 231	
BA35.30-P-1001-01J	Collar nut, rear axle shaft to rear axle shaft flange	self-locking	Nm	350	350
		not self-locking			
		Stage 1	Nm	–	–
		Stage 2	∠°	–	–

Nm Rear axle shaft

Number	Designation		Model 217	MODEL 222 except CODE Z07	
BA35.30-P-1001-01L	Collar nut/bolt, rear axle shaft to rear axle shaft flange	M26x1.5	Nm	350	350
		M29x1,5	Nm	-	-
		Stage 1	Nm	-	-
		Stage 2	∠°	-	-

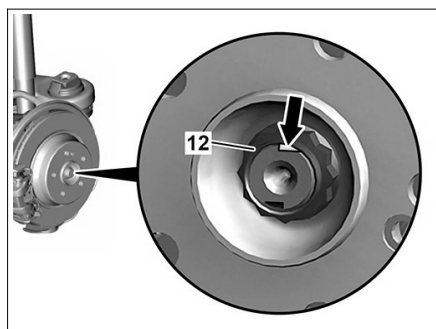

P35.30-2168-01



P35.30-2144-01

Detach

1.1 Model 204, 207, 212, 218, 219
Apply parking brake.

1.2 Model 172, 217, 222, 231
Operate electric parking brake (EFB).

2 Unscrew collar nut (12).

i The collar nut (12) should be replaced **each** time it is unscrewed. If a self-locking collar nut (12) was installed, the thread of the rear axle shaft must be cleaned. Use a suitable brush to remove residues of the thread locking compound (arrow, right picture).

Mount and secure

i Note variant of collar nut (12). The **non self-locking** variant is replaced by the **self-locking variant**.

3 Tighten collar nut (12).

i Observe specified tightening torque.

4 Secure collar nut (12) with caulker to ensure that there is no gap between the groove and locking collar of the collar nut (12).

i Secure collar nut (12) once.

5.1 Model 204, 207, 212, 218, 219
Release parking brake.

5.2 Model 172, 217, 222, 231
Release electric parking brake (EFB).