

AR35.20-P-0130-02TX	Pull inner bearing race off rear-axle shaft flange		
---------------------	--	--	--

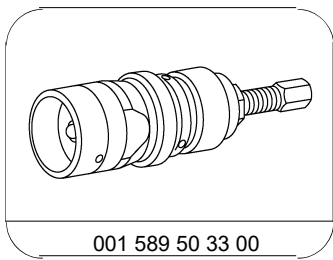

001 589 50 33 00

Puller

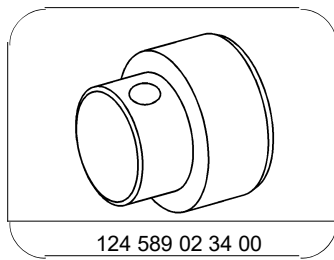

124 589 02 34 00

Thrust piece

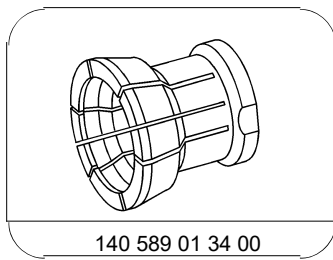

140 589 01 34 00

Chuck

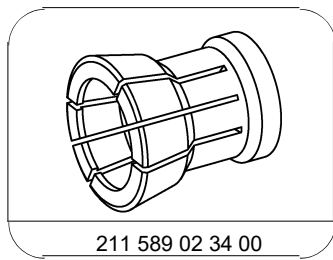

211 589 02 34 00

Chuck

- 1 Clamp rear axle shaft flange (1) in vise.
 Use protective jaws for vise.
- 2 Pry protective ring (3) off bearing inner race (2).
- 3 Mount thrust piece (04) on rear axle shaft flange (1).

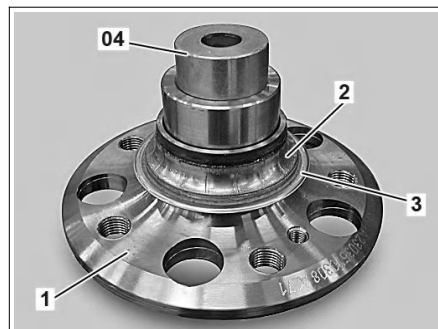

P35.20-2256-01

- 4 Screw collet (02) onto puller (01) and tighten.
 With model 231 use clamping pliers (02) 140 589 01 34 00.
- 5 Mount puller (01) onto bearing inner race and clamp securely into place.
- 6 Screw in thrust spindle (03) and pull bearing inner race off rear axle shaft flange (1) using puller (01).

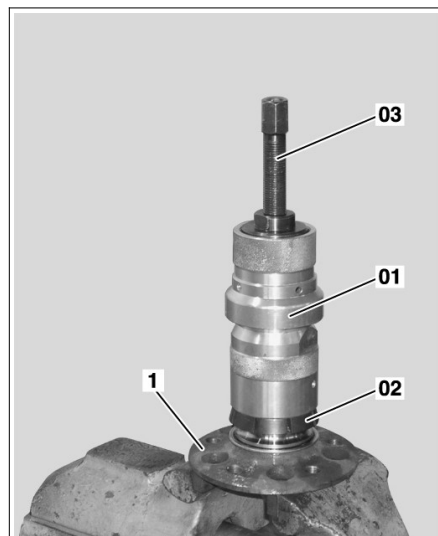

P35.20-2167-02