

35-500 Distinguishing features and installation survey for rear axle center piece in models 129 and 140

Distinguishing features of the rear axle center piece with 210 mm dia. crown wheel (reinforced)

- Breather on rear axle end cover
- Widened side bearing cover
- Connecting flange with deep-groove ball bearing
- Connecting flange with 102 mm bore pattern dia.
- Bore pattern dia. of 4-arm propeller flange 110 mm
- ASR speed sensor mounted on side bearing cover
- Oil capacity 1.4 liters

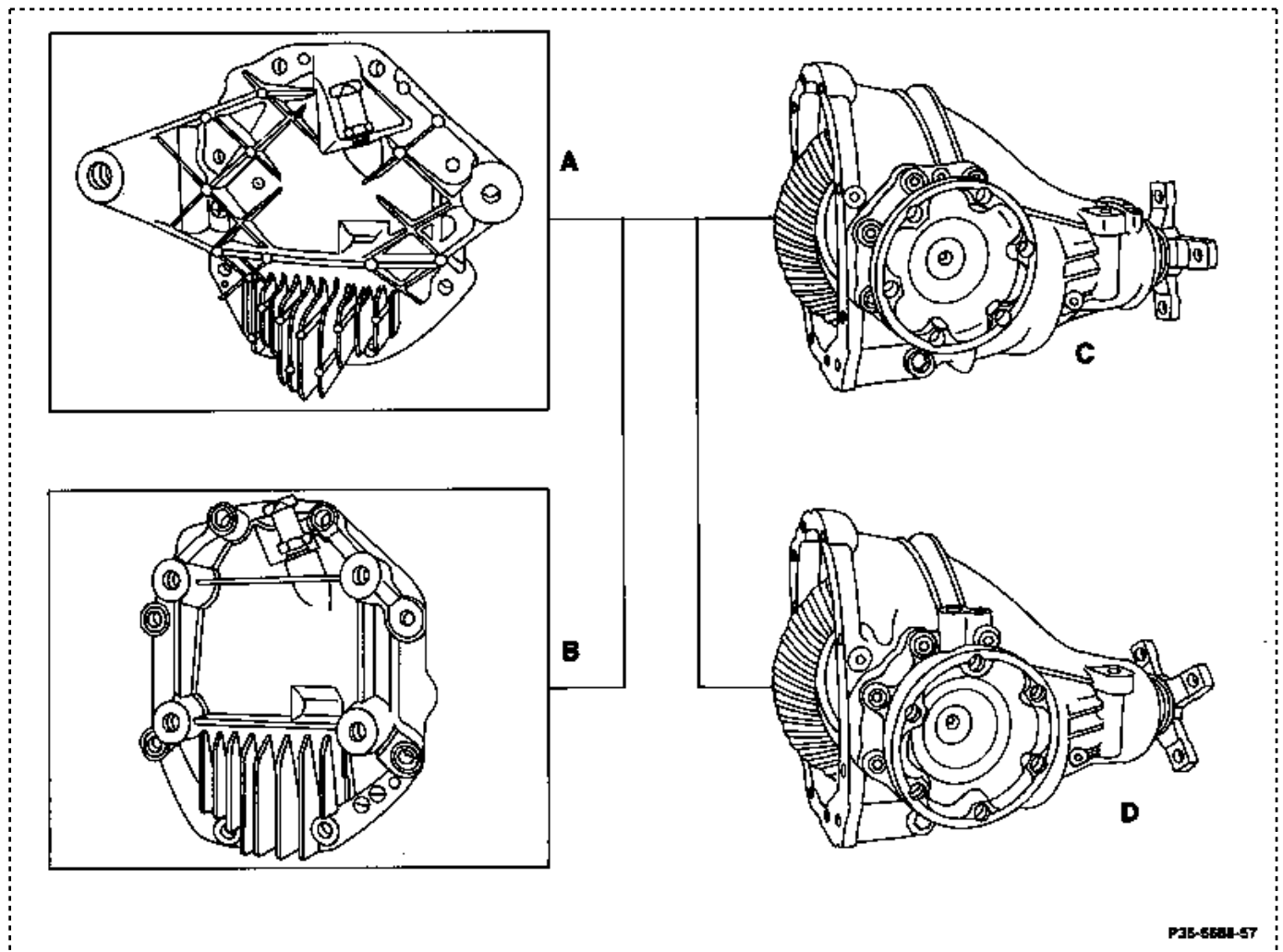

A Rear axle end cover, model 129
 B Rear axle end cover, model 140

C Standard housing with ABS
 D ASR housing

Installation survey: standard version

Rear axle center piece

Model	Ratio	No. of teeth	Oil capacity in liters
-------	-------	--------------	------------------------

129.067/076 140.050/051 140.070	2.65	45:17	1.4
140.056 140.076	2.64	37:14	

Installation survey: national version

Rear axle center piece

Model	Ratio	No. of teeth	Oil capacity in liters	Model year
Gulf States 140.057 140.076	2.24	47:21	1.4	As of 1993