

Installation Instructions

Conversion to 235/45 R 17 tyres and 8 1/2 J x 17 H 2 ET 30 multi-piece disk wheel 40.04

Model 124

Excluding vehicles with special bodywork, sedans with long wheelbase and 124.036.

All the work described in sections A, B, C, D, E and F must be carried out in full before the wheel/tire combination may be used.

The installation instructions are divided up into the following sections:

- A. Detaching the standard wheels
- B. Modifications to the chassis
- C. Modifications to the body
- D. Fitting the special wheels
- E. Tire inflation pressure/tire makes/using snow chains
- F. Speedometer correction
- G. Technical details
- H. Information for ordering replacement parts



up to 03/92, C740 0189

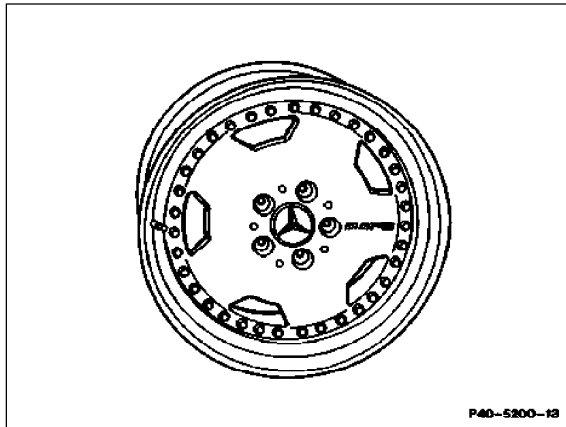

as of 03/92, H WA124 400 17 02

Note

An entry in the vehicle documents is required in the Federal Republic of Germany. For this a copy of the respective sample report must be submitted to the TÜV/TÜA.

A. Detaching the standard wheels

- 1 Remove wheel covers on steel disk wheels.
- 2 Slacken wheel bolts.
- 3 Raise vehicle.
- 4 Unscrew wheel bolts.

Note

When unscrewing the final wheel bolt be sure that the wheel does not suddenly tilt off the hub.

- 5 Remove wheel.

M

Five of the standard wheel bolts removed must be retained for the spare wheel. The standard production spare wheel can be used as a temporary spare wheel.

A maximum speed of 80 km/h is permissible due to the change in handling characteristics resulting from different tire rolling circumferences and wheel offsets. For this purpose, the standard production spare wheel is to be identified with the enclosed auxiliary sticker

(H WA201 584 04 39). Replace the temporary spare wheel with a standard wheel as soon as possible.

B. Modifications to the chassis

In conjunction with 17-inch AMG disk wheels, the front axle compression travel on all vehicle models must be reduced in order to ensure adequate clearance under extreme wheel compression.

- 1 Detach front wheels. (Refer to section A).
- 2 Use spring clamp 124 589 06 31 00 to clamp and remove front axle springs.

M

Do not use impact screwdrivers to clamp front axle springs.

- 3 Unscrew front axle damper strut at upper damper strut mounting (6) whilst steadying the piston rod.
- 4 Lower control arm and damper strut (support control arm).
- 5 Install spring travel limiting washer (5) on piston rod (1) over stop buffer (4).
- 6 Assemble damper strut and front axle spring in reverse sequence.

Note

Use new self-locking nuts (9) and washer (8) on the upper damper strut mounting. (Tightening torque 60 Nm).

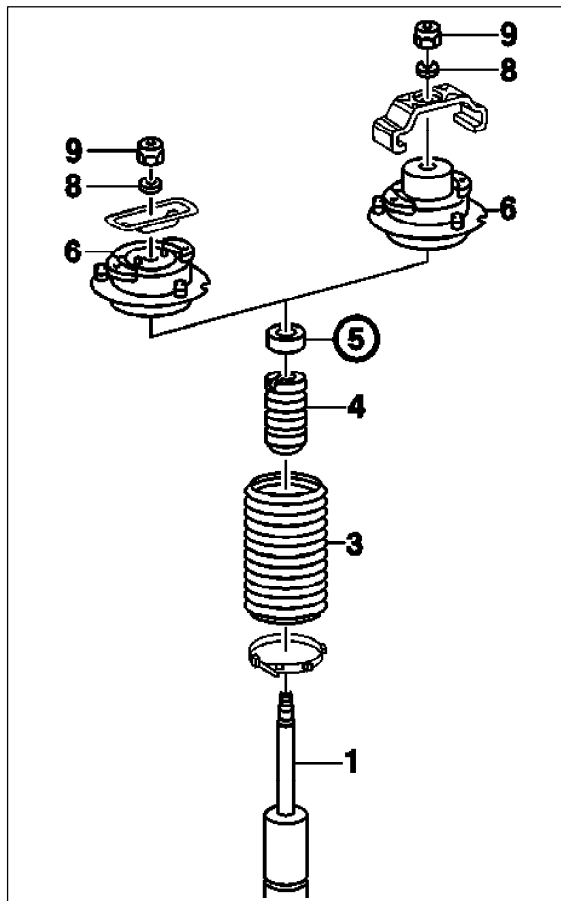

C. Modifications to the body

1 Adjusting the front fender

- 1.1 Detach side panel on the front fender from the fixing elements, pull to the rear and remove.

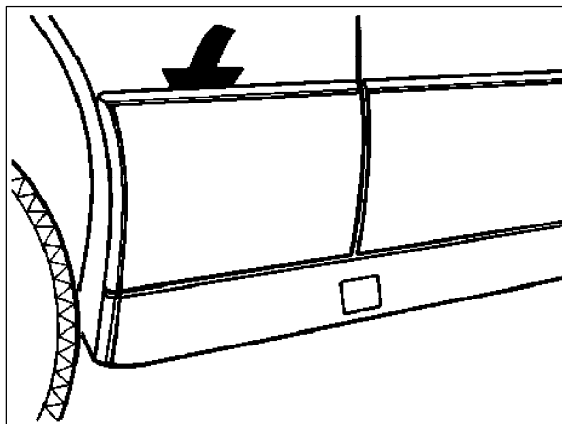

1.2 Unscrew bolts (A and B) on fender.

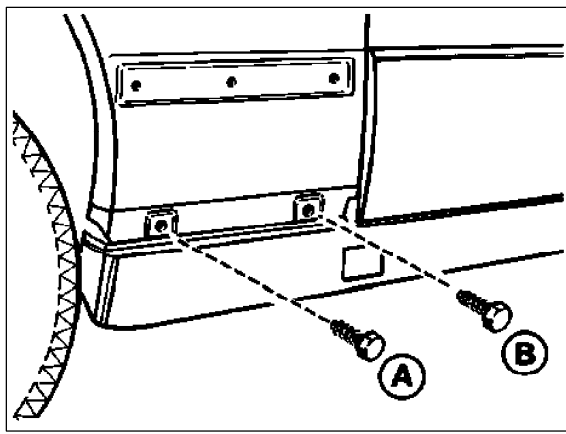

1.3 Slacken bolt (A) on side of bumper.

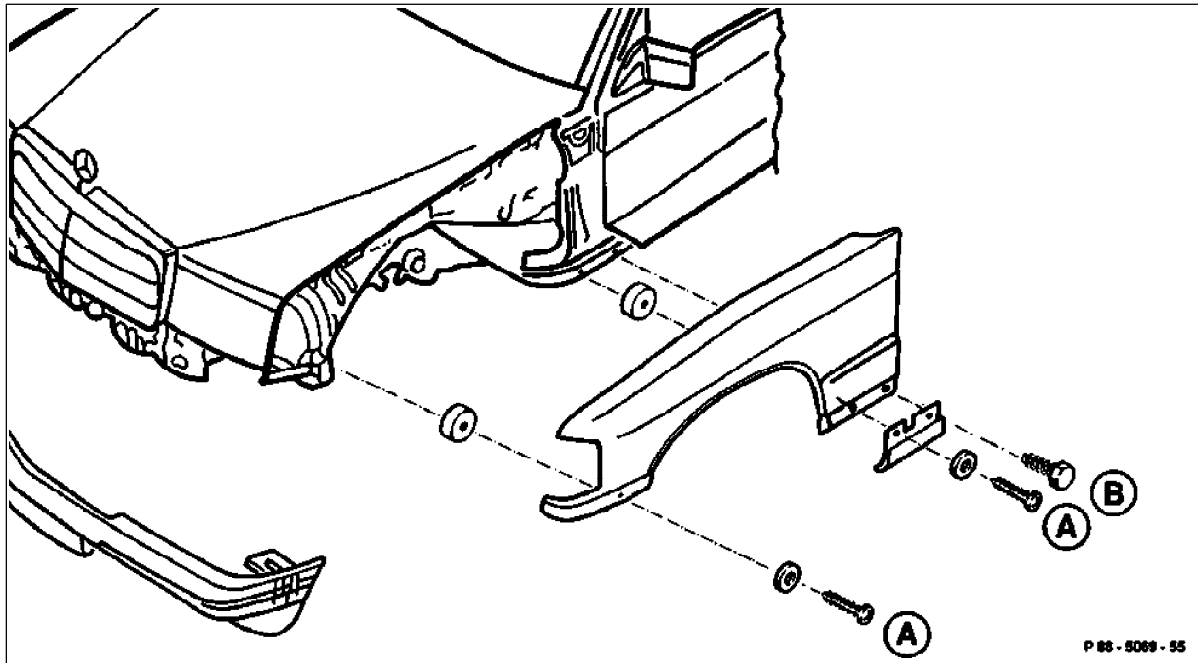
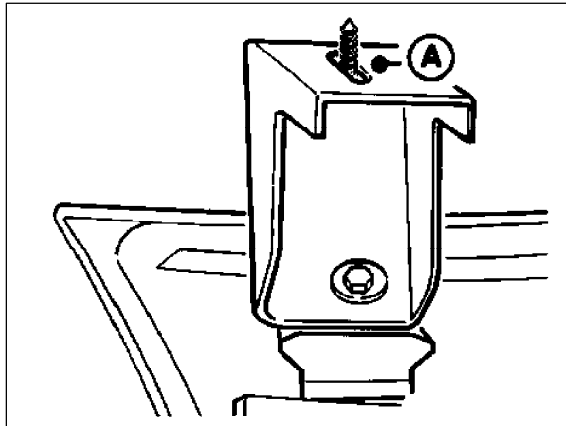

1.4 Press the side part of the bumper downwards and unscrew the bolts for fender fixing (A and B). Clamp a spacer between fender and body on the left and the right. The bore holes must align to permit troublefree fixing.

1.5 Place one spacer on the left and right between the fender and body in the side area of the bumper.

1.6 Tighten all bolts slightly in accordance with layout. Tighten bolts after a visual inspection.

2 Reworking the body at the front fenders

2.1 Flattening down front fender flange:

When converting to wider wheels and tyres the inside edges of the front fender must be flattened down to an angle of 110° over the complete wheel cutout.

2.2 If excessive PVC underbody protection has been applied, grind off excess before folding back the fender flange.

2.3 Using a hot air gun carefully heat up outer edges of fender to a maximum of $70^\circ - 80^\circ\text{C}$.

Note

Do not overheat paint whilst applying heat (max. 80°C).

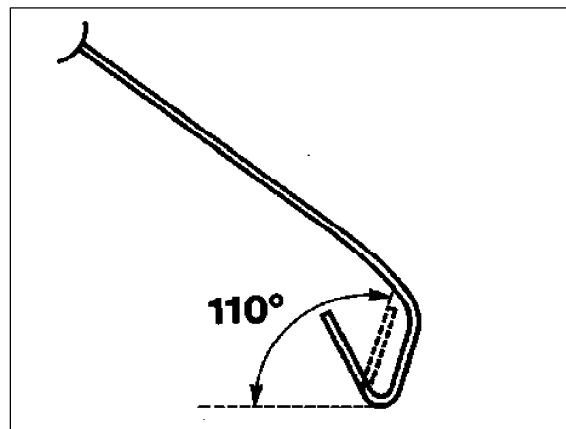

2.4 In the marked area (A), the fender flange is flattened down up to the inside of the fender in several stages. A plastic hammer must be used to avoid damaging the paint.

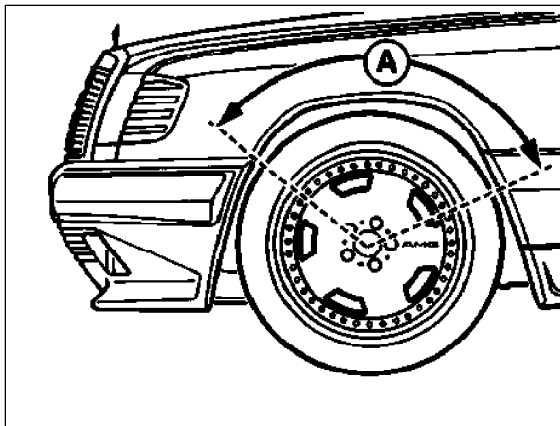

2.5 Flaring out the front fender:
Using a plastic hammer, apply even blows to flare out the edge of the front fender by 25° in the upper area.

Note

Reference dimension at the uppermost point of the wheel cutout: at least 275 mm measured over the center of the wheel below the edge of the wheel cutout and outer tube of the shock absorber strut.

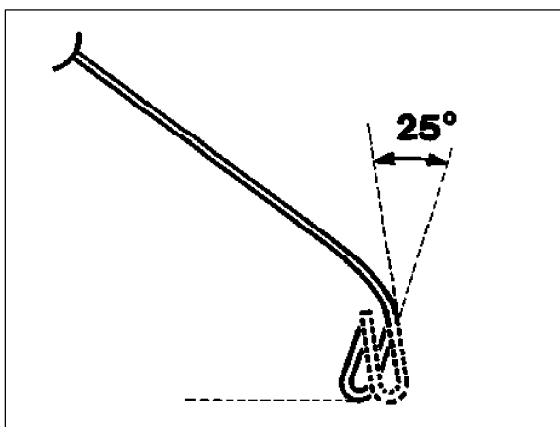

2.6 Allow front fender flare to curve smoothly back towards original, unflared line within the marked area (B).

Note

Rectify any damage to paint or underbody protection.

2.7 Grind off side panel to match the reworked fender contour and assemble.

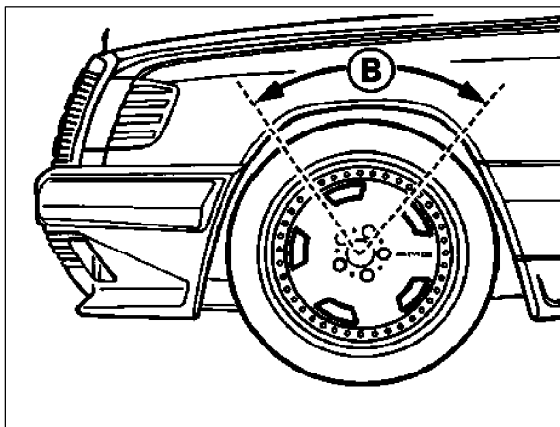

3 Reworking the body inside the wheel arches

3.1 Slacken the two bolts of the windscreen washer container on the right side. Tie up container so that it is not damaged when driving out the wheel arch.
Slacken ABS hydraulic unit and hydraulic fluid container on the left side and tie up.
Ensure that the units are not damaged whilst driving out the wheel arch.

3.2 Using a plastic hammer drive out wheel arch over an area of approx. 150 mm x 150 mm (A) approx. 10 mm towards the inside of engine compartment.

3.3 Remove weld stud (B) for fixing the inner fender and replace by a blind rivet with a large swage-head.

3.4 Treat wheel arch again with underbody protection. Spray the folded back fender edges with body cavity preserver.

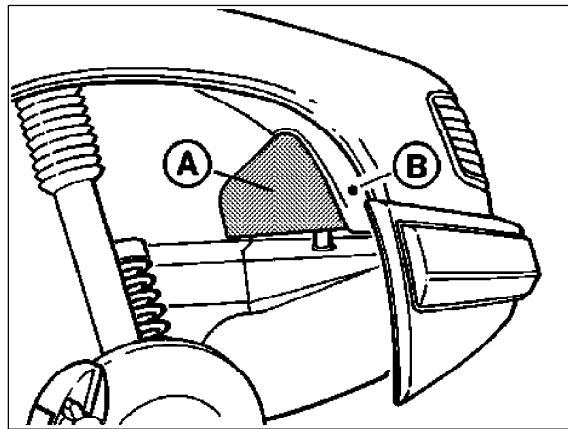

4 Body operations on rear fender

4.1 124 Sedan/coupé

Installing an angled sheet metal part:

- Remove side covers in luggage compartment.
- Free the side wall from wax and sealing compound in the area shown.
- Saw side wall along a length of 200 mm and extend outwards by 20 mm.
- Apply primer to angled sheet metal part (33 x 10 x 1 x 200 mm) and weld in using a TIG welder.
- Grind off weld, then apply primer and seal with body sealing compound.
- Coat with PVC underbody protection.

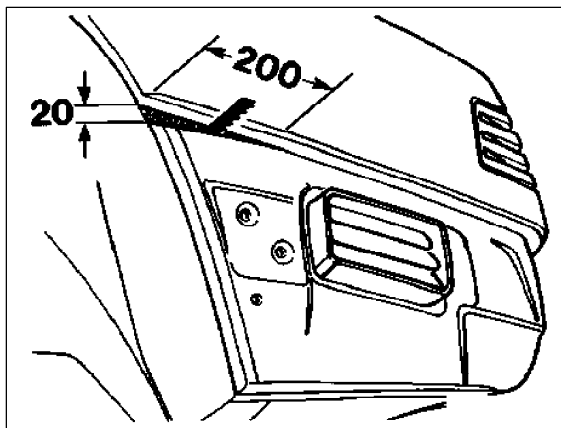

Note

Due to the enlarged rear production wheelhouse inner panels, the use of an angled bracket as described in 4.1 is not necessary on model 124.061 (300CE-24 Cabrio).

4.2 124 T-model

Installing a sheet metal strip:

- Remove spare wheel and jack from luggage compartment.
- Free the wheel arch from wax and sealing compound in the area shown.
- Saw wheel arch along a length of 200 mm, 30 mm parallel to outer body contour and extend outwards by 15 mm.
- Apply primer to sheet metal strip and weld in from the wheel arch side using a TIG welder.
- Grind off weld, then apply primer and seal with body sealing compound.
- Coat with PVC underbody protection.

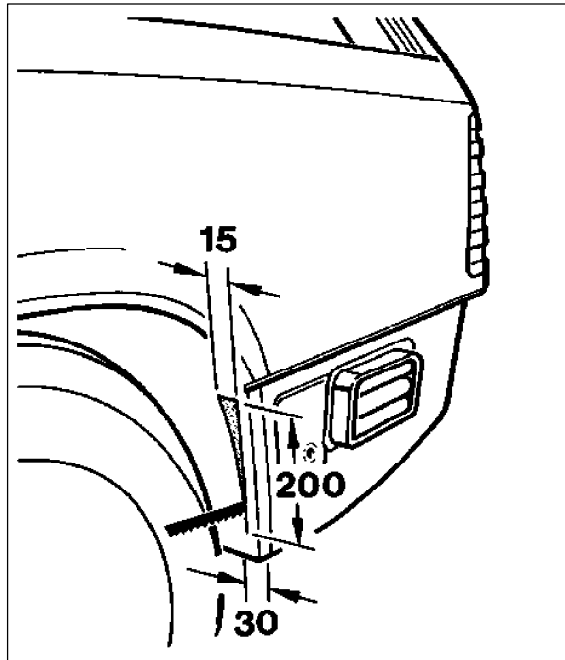

5 Folding back the edge of rear fender

5.1 If excessive PVC underbody protection has been applied, grind off excess before folding back the edge of the fender.

5.2 Using a hot air gun carefully heat up outer edges of fender to a maximum of 70° - 80°C.

Note

Do not overheat paint whilst applying heat (max. 80°C).

5.3 In the marked area (A), the edge of the fender is flattened down as far as the inside of the fender in several stages.

A plastic hammer must be used to avoid damaging the paint.

Note

Rectify any damage to paint or underbody protection.

5.4 Treat wheel arch again with underbody protection. Spray the folded back fender edges with body cavity preserver.

5.5 Grind off protective side molding to match the reworked fender contour and assemble.

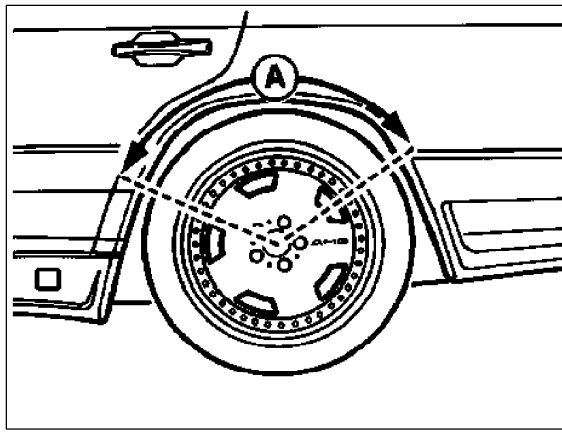

D. Fitting the special wheels

1 Screw in centering bolts (tool kit) in upper tapped hole of the wheel hub.

2 Put on AMG light alloy wheel and press onto wheel hub.

3 Screw in wheel bolts and tighten positively. The wheel bolts must be dry and free from grease. Ensure that the wheels are not tensioned by tightening the wheel bolts on one side. (Tighten wheel bolts diagonally in several stages).

M

Only **M12×1.5×40 mm** spherical collar bolts supplied with the wheel are to be used for the wheel fixing.

4 Unscrew centering bolt and replace by a wheel bolt.

5 Lower vehicle.

6 Evenly tighten wheel bolts diagonally to a tightening torque of 110 Nm.

M

AMG light alloy wheel bolts must be retightened after 100-500 km. (Tightening torque 110 Nm).

Note

For reasons of safety and standardized appearance, wheel no. C740 0189 and wheel no. H WA124 400 17 02 must not be mixed but only fitted to the vehicle in sets.

E. Tire inflation pressure/tire makes/using snow chains

1 The **tire inflation pressure** is to be adjusted in accordance with the production tire inflation pressure plate in the gas tank flap.

2 Recommended **tire makes** can be obtained from the current Service Information "Summer tires in conjunction with AMG special equipment and AMG light alloy wheels from the accessory range".

3 Fitting **snow chains** in conjunction with the AMG wheel/tire combination is not permitted.

F. Speedometer correction

By contrast with standard production tyres the rolling circumference of retrofitted tyres is in a range which necessitates checking and correcting the speedometer calibration if required. This can be performed by an authorized dealer of the respective instrument manufacturer (VDO/Motometer).

G. Technical details

Manufacturer:	AMG/OZ Racing	AMG/OZ Racing
Model:	C740 0189	H WA124 400 17 02
Wheel size:	8 1/2 J×17 H 2	8 1/2 J×17 H 2
Offset:	30 mm	30 mm
Pitch circle:	d=112 mm, 5-hole	d=112 mm, 5-hole
Permitted wheel load:	630 kg at r _{dyn} =321 mm	630 kg at r _{dyn} =321 mm

Centering:	Central centering d=66.5+0.1	Central centering d=66.5 H8
Type:	Multi-piece light alloy wheel with pressed outer and inner rim well and forged wheel spider.	Multi-piece light alloy wheel with pressed outer and inner rim well and forged wheel spider.
Width of outer rim well:	1 inch	1 inch
Width of inner rim well:	7 1/2 inch	7 1/2 inch
Wheel spider:	flange-mounted from inside	flange-mounted from inside
Marking:		
Outer side of wheel:	AMG	AMG
Inner side of wheel:	C740 0189 8 1/2 J×17 H 2 e30 Date of manufacture AMG Germany OZ Racing	Ⓐ H WA124 400 17 02 8 1/2 J×17 H 2 e30 Date of manufacture AMG Germany OZ Racing JWL symbol
Valve:	Metal screw-on valve	Metal screw-on valve
Fixing:	Only with M12×1.5×40 mm spherical collar bolts supplied by the wheel manufacturer	Only with M12×1.5×40 mm spherical collar bolts supplied by the wheel manufacturer
Tightening torque:	110 Nm	110 Nm
Balance weights:	Only adhesive weights as used in MB production are permitted.	Only adhesive weights as used in MB production are permitted.

H. Information for ordering replacement parts

Replacement parts up to 03/92

Designation	Part no.
8 1/2 J×17 H 2 ET 30 light alloy disk wheel with fixing material and wheel trim	H WA124 400 12 02
Wheel trim	H WA124 400 01 25
Spherical collar bolt M12×1.5 Shank length L=40 mm	H WA201 401 02 70
Metal screw-on valve	H WA129 400 01 13
Fender extension kit	H WA124 880 01 97
Spring travel limiter kit	H WA124 323 01 44

Note

A set of wheel locking bolts (Part no.:
H WA201 400 03 70) can be supplied upon request.

Replacement parts as of 03/92

Designation	Part no.
8 1/2 J×17 H 2 ET 30 light alloy disk wheel with fixing material and wheel trim	H WA124 400 18 02
Wheel trim	A201 400 04 25

Spherical collar bolt M12×1.5 Shank length L=40 mm	A124 400 00 70
Metal screw-on valve	H WA129 400 01 13
Fender extension kit	H WA124 880 01 97
Spring travel limiter kit	H WA124 323 01 44

Note

A set of wheel locking bolts (Part no.:
B6 6 40 8102) can be supplied upon request.