

# 42-0010 Bleeding brake system and replacing brake fluid

Operation no. of operation texts and work units or standard texts and flat rates:  
42-1351, 42-1356, 42-1421 and 42-1431

## A. Bleeding brake system

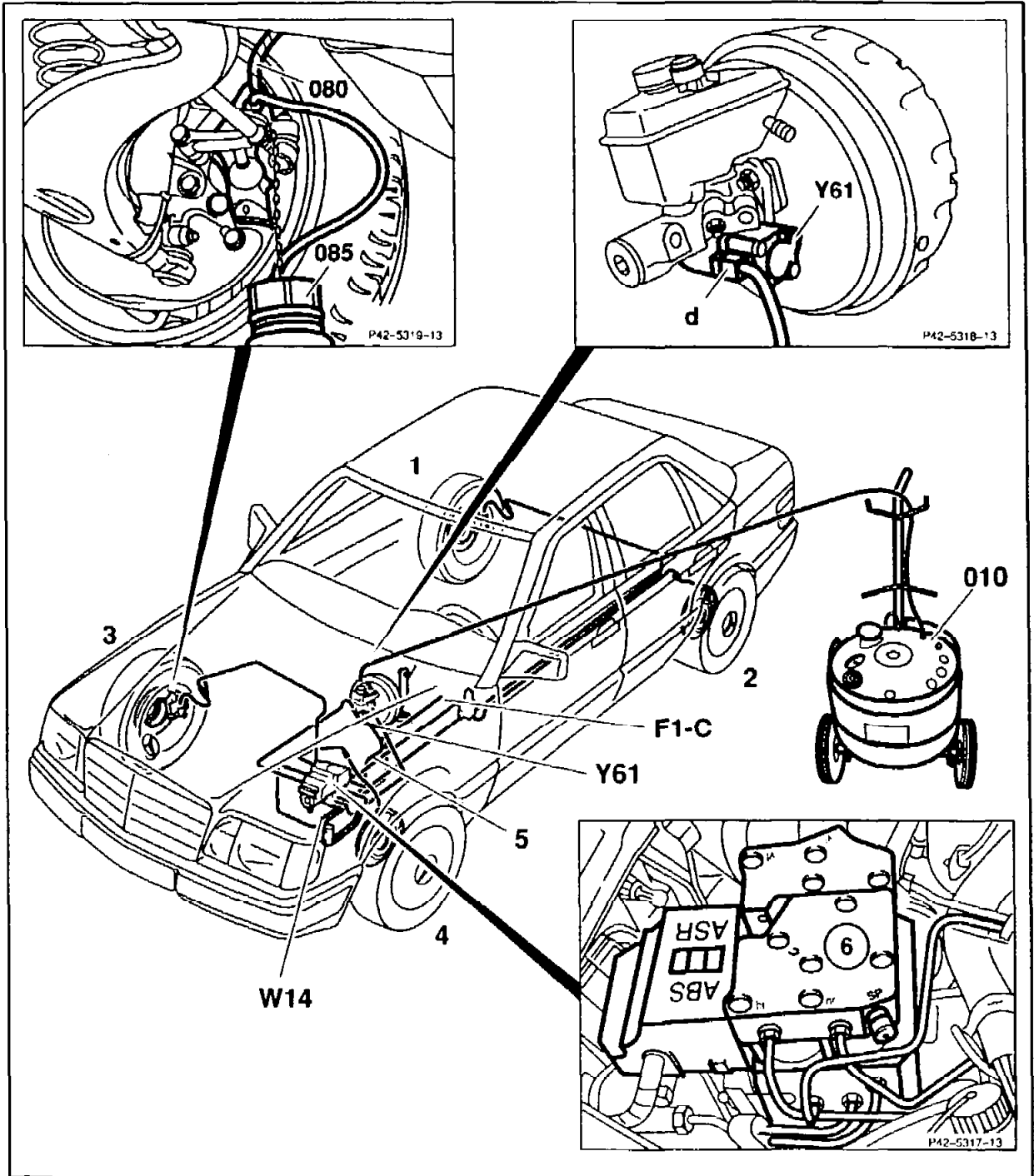

**All vehicles**

Ignition .....

switch off.

**Model 124.036 as of 02/93**

Master brake cylinder switchover valve (Y61) with wiring harness (5) .....

actuate by connecting and disconnecting coupling (d) on harness (5). Wiring harness (5) shop made.

Wiring harness (5) .....

connect to fuse C, terminal 30 (F1-C) and ground at hydraulic unit bracket (W14). Wiring harness (5) shop made.

**All vehicles**

Screw cap .....

unscrew, screw on.



Observe Note on brake fluid and disposal regulations for brake fluid (see pages 8 and 9).

Filling and bleeding unit (010) .....

connect (observe equipment manufacturer's instructions). Bleed brake system using box wrench (080) 140 589 03 09 00 and receptacle (085).

Start bleeding operation at brake caliper (1) (bleeding pressure: **2 bar**).

Tightening torque of bleed screw  $7 \pm 1$  Nm or 8–12 Nm (front axle, models 124.036 with aluminum caliper and 201.035 Evolution II).

**a) Vehicles without ASR**

On each brake caliper (1–4) hold bleed screw open until **clear**, bubble-free brake fluid flows out (approx. **80 cm<sup>3</sup>**).

**b) Vehicles with ASR**

- Following work on the brake system downstream of the ASR control unit (6) (brake calipers, brake hoses, brake lines; **ASR supply reservoir not drained**), on each brake caliper (1–4) hold bleed screw open until **clear**, bubble-free brake fluid flows out (approx. **80 cm<sup>3</sup>**).

**Model 124.036 ab 02/93**

Shop-made wiring harness (5) .....

**Vehicles with ASR**

Ignition .....

Cover on ASR hydraulic unit (6) .....

ASR pressure reservoir .....

Engine .....

Bleed screw "SP" .....

Bleed screw "SP" .....

Engine .....

**All vehicles**

Filling and bleeding unit (010) .....

- Following work on the ASR hydraulic unit (6) or upstream of the ASR hydraulic unit (ASR pressure reservoir, ASR pressurizing pump, tandem master brake cylinder, brake lines), on each brake caliper (1-4) hold bleed screw open until clear, bubble-free brake fluid flows out (approx. 200 cm<sup>3</sup>).

disconnect, connect vehicle harness.

**OFF.**

remove, install.

drain through bleed screw "SP".

start.

open until clear, bubble-free brake fluid flows out (approx. 80 cm<sup>3</sup>).

close, wait for charging operation for pressure reservoir (charging pump runs audibly for approx. 30 s).

switch off.

disconnect, correct brake fluid level in brake fluid supply reservoir.

**Special tools**

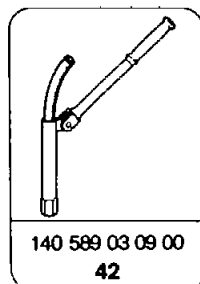

Shop-made wiring harness

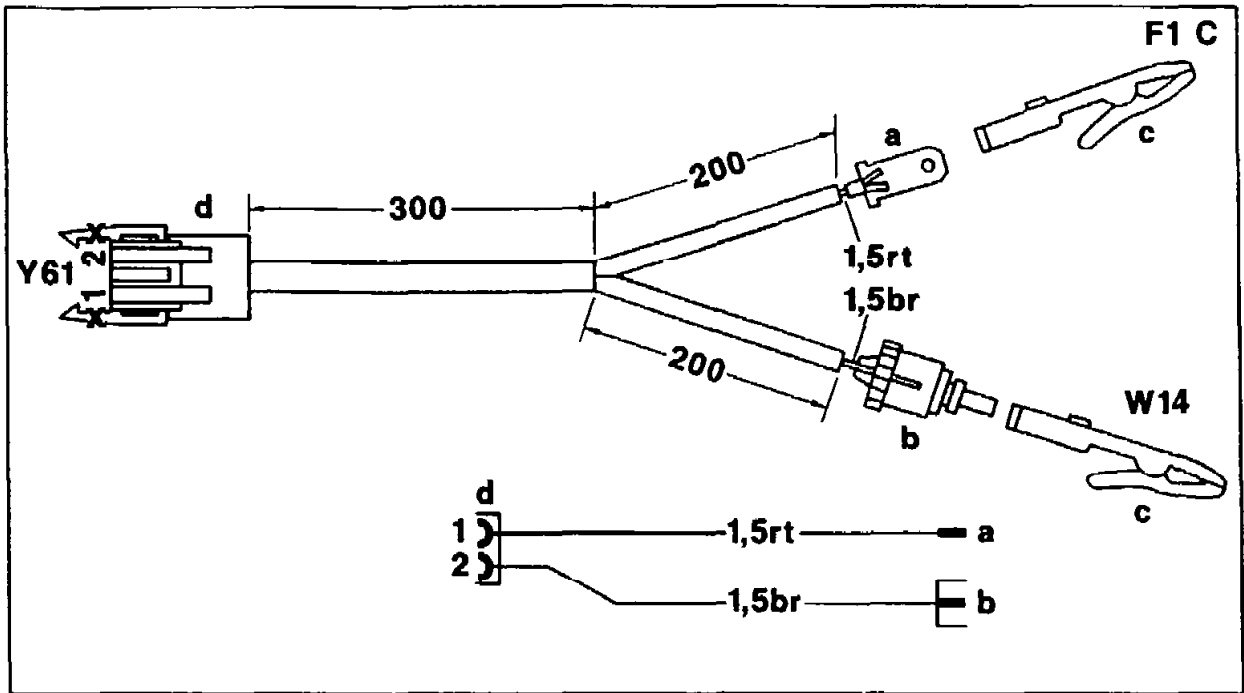

P42-5274-55

Shop-made wiring harness (cut off at connector "d" catch).

Item	Designation	Part no.	Quantity
a	Flat plug	001 545 86 28	1
b	Plug housing, single	011 545 10 28	1
	Cap	009 545 14 28	1
	Plug pin, 4 mm dia.	011 545 12 28	1
c	Alligator clip	809 505 (from electrical connection kit) 201 589 00 99 00)	2
d	Connector, double	012 545 04 28	1
	Socket, 4 mm dia.	001 545 44 26	2

**Note**

On caps with vent hole (up to approx. 9/90), ensure that the hole (arrow) is not plugged.

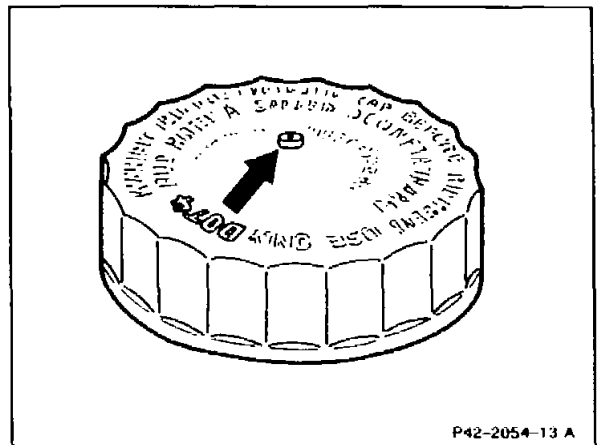

P42-2054-13 A

## B. Replacing brake fluid

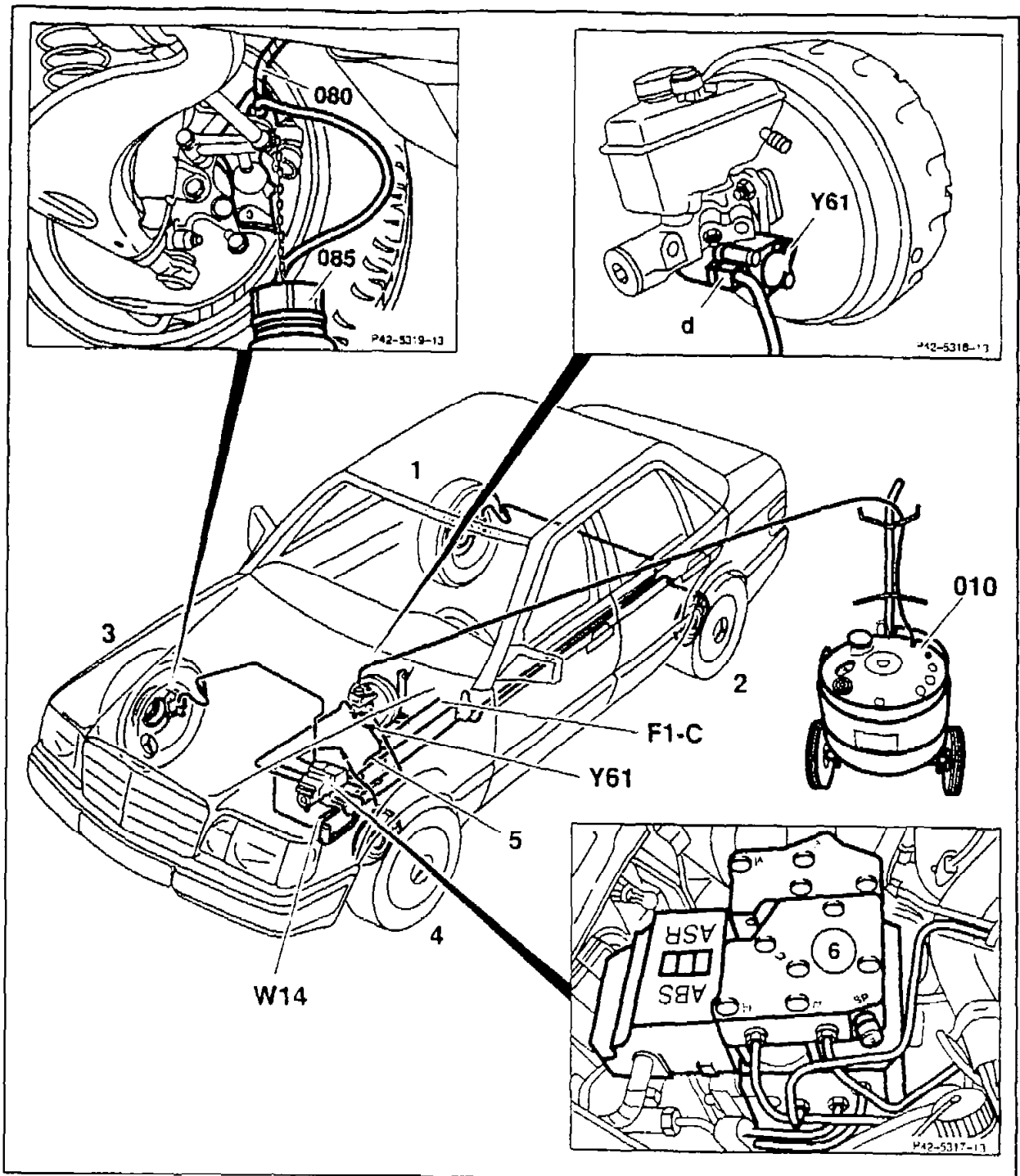

P42-5321-61

Brake fluid level in brake fluid supply reservoir . . . note.

Cap .....

expose, screw off and drain brake fluid supply reservoir chambers down to a fluid level of approx. 10 mm. Observe Note on brake fluid and disposal regulations for brake fluid (see pages 8 and 9).



Do not completely drain brake fluid supply reservoir to prevent air from getting into the brake system. If drained completely, it is necessary to bleed the entire brake system (special bleeding procedure required for vehicles with ASR).

**Vehicles with ASR:** Ignition .....

**OFF.**

Cap on hydraulic unit .....

remove, install.

Pressure reservoir .....

drain through bleed screw "SP"

**All vehicles:** Replace brake fluid .....

**a) with filling and bleeding unit**

- Observe equipment manufacturer's operating instructions.

- Allow approx. 80 cm<sup>3</sup> of brake fluid to flow out of each brake caliper and from the clutch slave cylinder (manual transmission) to ensure that the lines and pressure cylinders for the brake calipers are filled with new brake fluid. Start bleeding operation at brake caliper 1. Tightening torque for bleed screw 7 ± 1 Nm or 8–12 Nm (front axle, model 124.036 with aluminum caliper and 201.036 Evolution II).

**b) without bleeding unit**

Fill brake fluid supply reservoir up to "maximum mark". Pump old brake fluid out of each brake caliper and from the clutch slave cylinder (manual transmission) with 10 strokes of the pump.

**Note**

After each stroke of the pump, close the respective bleed screw and **slowly** release the brake pedal to prevent air from being drawn in through the bleed screw thread and to ensure that a sufficient quantity of brake fluid can flow in from the brake fluid supply reservoir.

Start bleeding operation on brake caliper 1. Tightening torque for bleed screw 7 ± 1 Nm or 8–12 Nm (front axle, model 124.036 with aluminum caliper and 201.036 Evolution II).

**Vehicles with ASR:** Engine .....

Bleed screw "SP" .....

Bleed screw "SP" .....

Engine .....

**All vehicles:** Brake fluid level in brake fluid supply reservoir .....

Screw cap .....

start.

open until clear, bubble-free brake fluid exits (approx. 80 cm<sup>3</sup>).

close, wait for charging operation for pressure reservoir (charge pump runs audibly for approx. 30 s).

shut off.

correct.

⚠

Do not exceed original brake fluid level to avoid overfilling the brake fluid supply reservoir after replacing the brake pads.

screw on.

**Special tool**

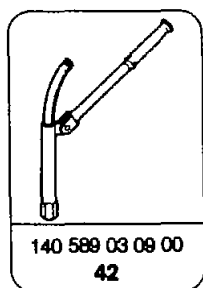

**Note**

On caps with vent hole (up to approx. 9/90), ensure that the hole (arrow) is not plugged.

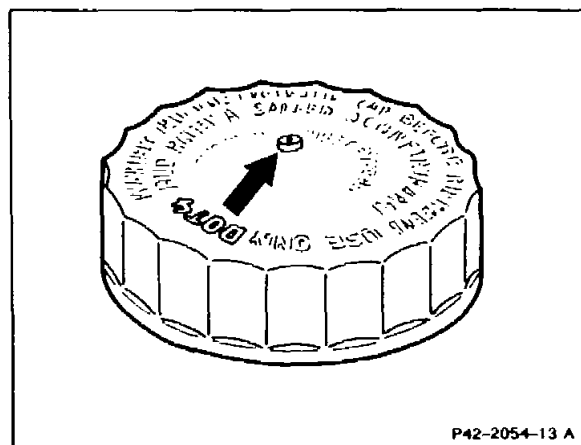

P42-2054-13 A

### Note on brake fluid

Use only approved brake fluid, see Specifications for Service Products, sheet 331.0.

Regardless of how replacement is accomplished, clear brake fluid free of bubbles should always exit through the bleed hose.

In the course of operation, the boiling point of the brake fluid decreases as a result of constant absorption of moisture in the air. This can result in the formation of vapor bubbles in the brake system under severe operating conditions.

For this reason it is necessary to replace the **brake fluid annually** on models 124 and 201 up to 03/91 (except for 124.036) and every **two years** on models 124 and 201 as of 04/91 as well as 124.036, 129, 140 and 202.



#### Use caution when handling brake fluid

- a) Fill brake fluid only into containers where inadvertent human consumption of the brake fluid is excluded (**lethal dose 100 cm<sup>3</sup>**).
- b) Even minor traces of mineral oil can lead to failure of the brake system resulting from decomposition of the rubber parts. This should be observed particularly for colorless to yellow brake fluid, because this poses the greatest risk of confusion.

If mineral oil is noticed or suspected in the brake system, proceed as follows:

1. Replace tandem master brake cylinder and brake fluid supply reservoir.
  2. Thoroughly flush entire brake system with new brake fluid.
  3. Replace all brake components with rubber parts such as the brake calipers, brake hoses, ABS or ASR hydraulic unit, pressure reservoir and pressurizing pump, which may have come into contact with mineral oil.
  4. Bleed brake system.
- c) Do not allow brake fluid to come into contact with the vehicle paintwork, because it contains constituents which act as a paint solvent.
  - d) Brake fluid is highly hygroscopic, i.e. it absorbs moisture from the air, lowering the boiling point. For this reason, store brake fluid only in properly sealed storage vessels.
  - e) Do not re-use the brake fluid pumped out while bleeding, because it may contain foreign particles which would then be reintroduced into the brake system.





**Note on disposal of brake fluid**

Dispose of used brake fluid as polluting waste. (See disposal instructions in MBVD Environmental Protection Catalogue Chapter 2.6 – pages 2–43). Brake fluid which does not contain oil can be recycled.

This requires that the brake fluid be collected and stored according to type.

For this purpose we recommend using the collection system from the Schröder company described in the MBVD Workshop Equipment Catalogue under the following numbers:

0210	2200 E	0705	Collection vessel
0210	2200 E	0701	Drain vessel
0210	2200 E	0702	Hand pump
0210	2200 E	0703	Transport rack

The same description is given in the Workshop Equipment Manual, Volume 2, Chapter U, Group 00 (22).

