

**MODEL 210**

- 1 Water collector
- 2 Plastic rivet
- 3 Main air flap
- 4 Smog sensor
- 5 Control module box
- 6 Wiper rubber pads
- 7 Wiper unit mount
- 8 Air intake clips
- B31x1 Smog sensor connector

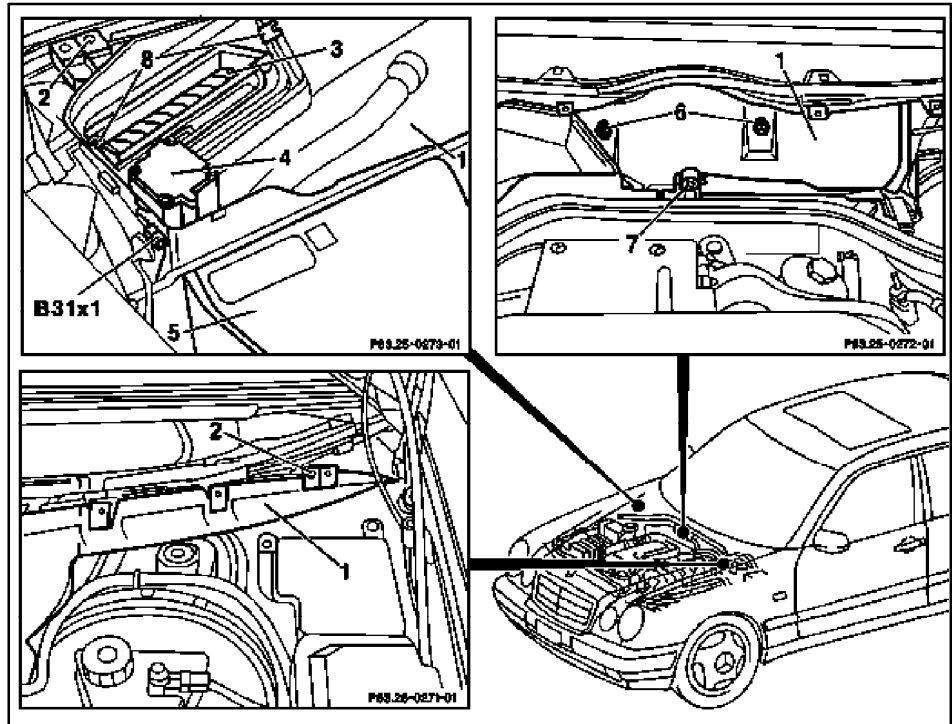

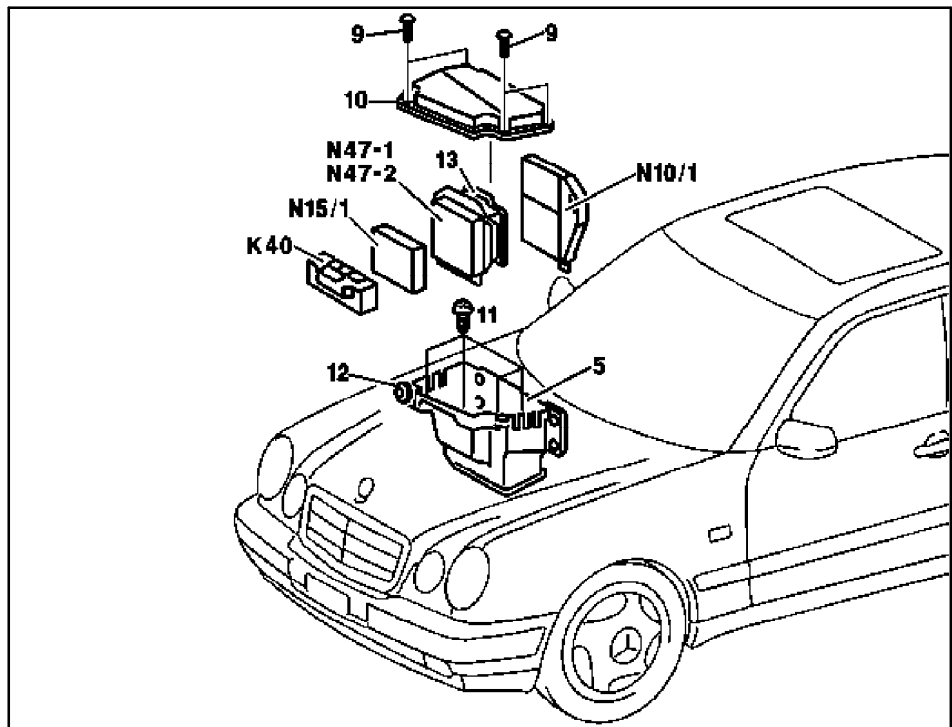

P83.25-0274-06

- 5 Control module box
- 9 Cover screw
- 10 Cover
- 11 Screw
- 12 Clamping screw
- 13 Engine control module
- K40 Relay unit (HFM-SFI, HFM-LP, ME 1.0, EDC, basic function)
- N10-1 Multi-function control module (convenience feature CF, windshield wiper, rear window defroster, box fan)
- N15/1 5-speed automatic transmission control module (EATC)
- N47-1 ASR/SPS control module
- N47-2 ETS/SPS control module



P83.25-0281-06

☒ ☒		Removal, installation	
1	Remove left air inlet		AR83.25-P-1403F
2	Remove right air inlet		AR83.25-P-1404F
3	Remove windshield wiper		AR82.30-P-6400F
4	Remove rubber pads (6)		
5	Remove windshield wiper mount (7) Unscrew screw		
6	Unclip clips (8)		

7	Remove plastic rivet (2)		
8	Disconnect connector for smog sensor (B31x1)	Vehicles with air conditioning (automatic) (code 581)	
9	Disconnect ground lead on battery	 Insulate terminal on ground lead to prevent unintentional contact between connected ground lead and ground point W10	AR54.10-P-0003A
10	Unscrew screws (9) and remove cover (10)	 <b>Installation:</b> Ensure that gasket for cover is properly seated	
11	Remove control module N10-1 from control module box		AR54.20-P-1257-01A
12	Loosen clamping screw (12)		
13	Unscrew screws (11) and move upper section of control module box (5) toward front		
14	Remove water collector (1)	 When removing and installing the water collector (1) ensure that the main air flap is not damaged	
15	Reinstall in opposite order		