

MODEL 210.2

- 1 Front ball head
- 2 Gas pressure strut
- 3 Protective sleeve
- 4 Rear ball head

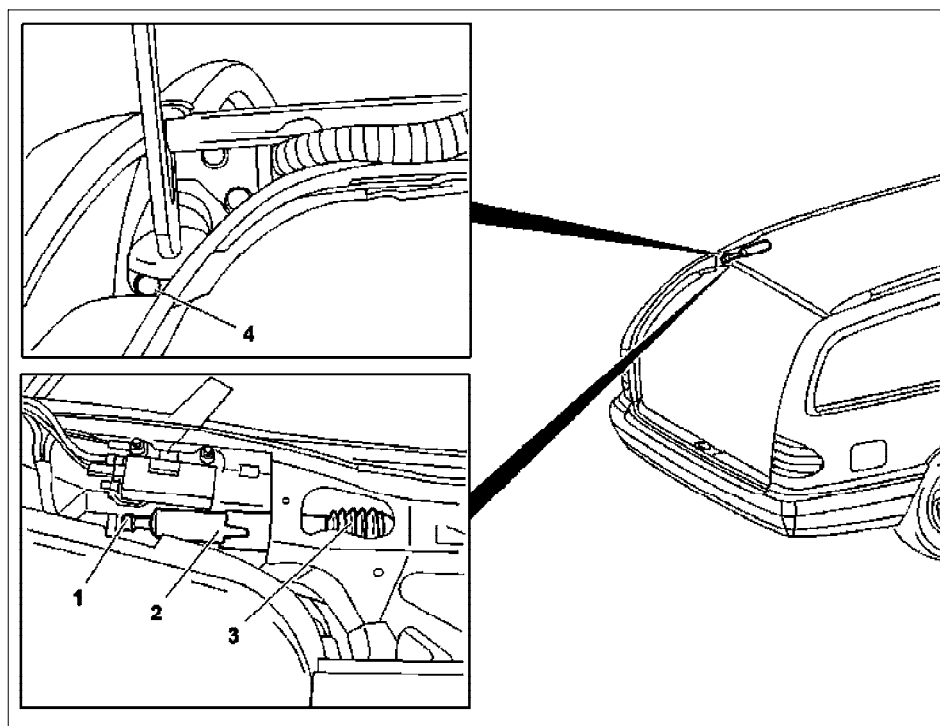

P72.20-0232-06

☒ ☒	Removal, installation		
1	Remove rear roof frame paneling		AR68.30-P-4470A
2	Secure tailgate with support		
3	Lift retainer on front ball head (1)	i Do not remove retainer, otherwise tension is lost	
4	Lift retainer on rear ball head (4)	i Do not remove retainer, otherwise tension is lost	
5	Remove gas pressure strut (2) together with protective sleeve (3)	i When replacing gas pressure strut Dispose of gas pressure strut (old part)	OS00.00-P-1001-01A
6	Reinstall in opposite order		

MODELS 202.07 /08 /18, 210.2**Model 202**

- 1 Center roof frame covering
- 2 Side roof frame covering
- 3 Mount for double sun shade
- 4 Rear courtesy light

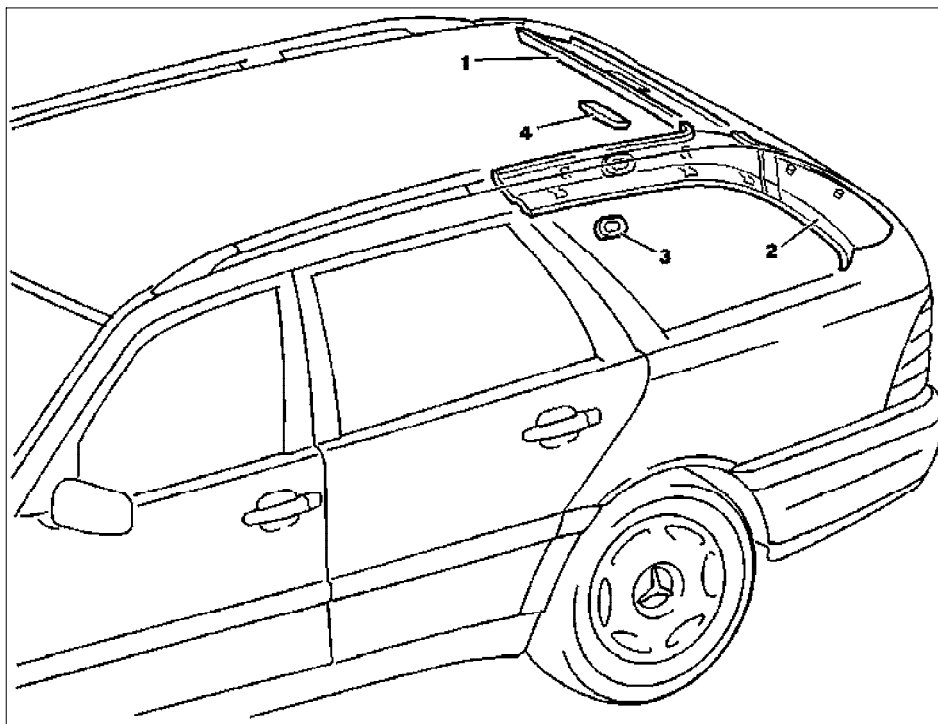



P68.30-0270-06

Model 210

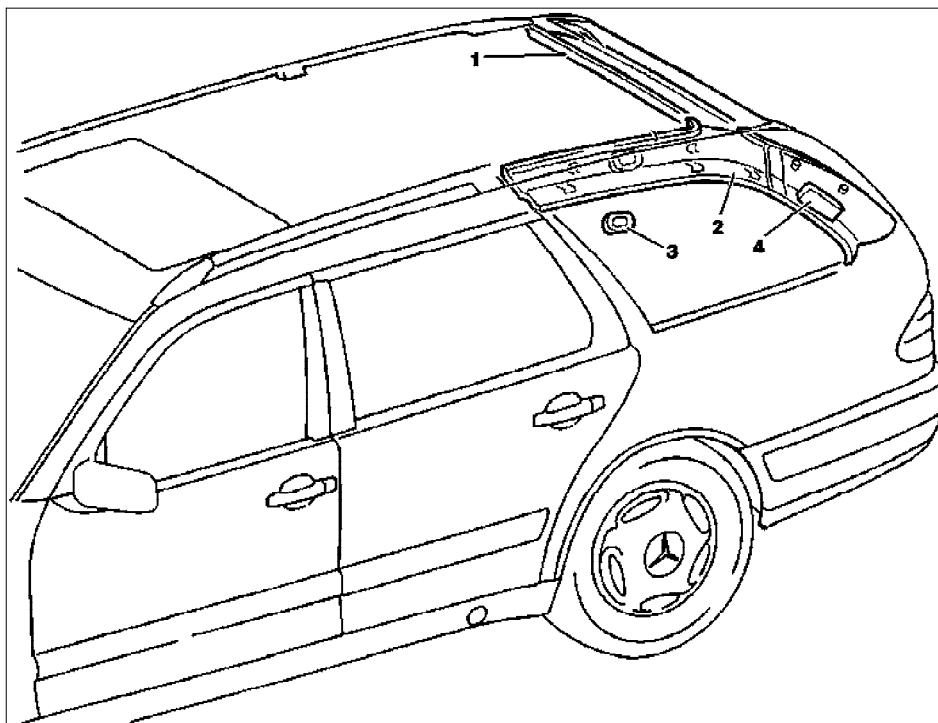
- 1 Center roof frame covering
- 2 Side roof frame covering
- 3 Mount for double sun shade
- 4 Rear courtesy light



P68.30-0303-06

 	Removing, installing		
1	Remove paneling on C-pillar	Model 202 Model 210	AR68.30-P-4490EA AR68.30-P-4490FA
2	Remove mount for double sun shade (3)		
3	Unclip side roof frame cover (2) and pull out downward		
4	Pull out rear lamp (4) downward		
5	Unclip center roof frame cover (1) downward and pull out toward front		

6	Install in the reverse order	<p>i Installation: Model 210.2 with folding bench storage compartment, opposite the direction of motion (Code 844)</p> <p>When replacing the roof frame trim openings must be made at the rear for the belt deflectors. Refer to: "</p> <p>Stamping opening in trim of rear roof frame</p> <p>i Without windowbag (code 290)</p> <p>Make opening in trim of rear roof frame</p> <p>i With windowbag (code 290)</p>	<p>AN68.30-P-4470-01FA</p> <p>AN68.30-P-4470-02FA</p>
---	------------------------------	--	---

1 Clamp gas-operated strut in machine vise of pillar drilling machine.

i Conrod must point away from body, no other persons must be within danger area.

2 Drill gas-operated strut approx. 20 mm (dimension a) from bottom of gas-operated strut z with a 3 mm drill (arrow). Drill with as little force as possible.

3 Unclamp gas-operated strut, pump gas-operated strut empty by pressing conrod in several times.

i Observe regulations for disposal of hydraulic oil.

4 Dispose of gas-operated strut (worn part).

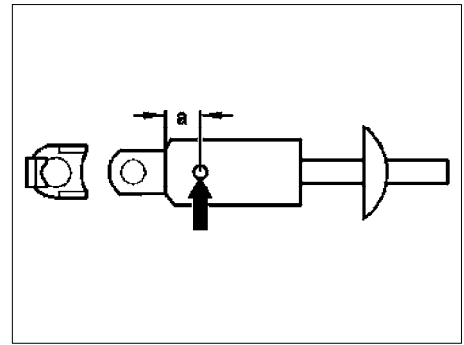

P88.40-0216-01