

MODEL 210.0 /2 as of 1.6.99

- 1 Fender
- 2 Screws
- 3 Cover
- 4 Screws
- 5 Screw
- 6 Screws
- 7 Mount

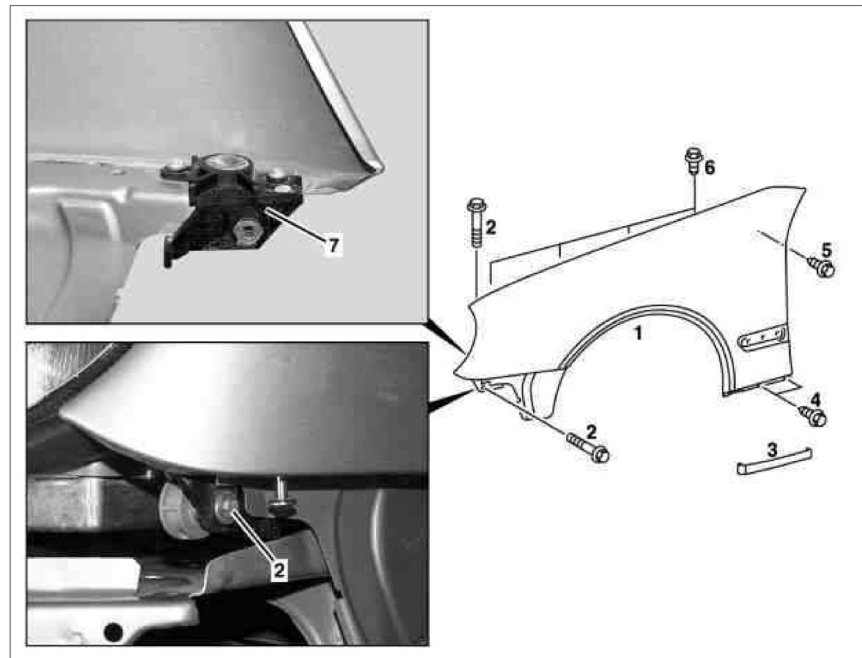

P88.10-2027-06

	Removal, installation		
	Removing inner fender is not necessary		
1	Remove front bumper		AR88.20-P-2000FA
2	Unscrew screws (2) from headlamps		
3	Carefully press off cover (3) and remove		*115589035900
4	Unscrew screws (4)		For this purpose unscrew rocker panel in front area and carefully pull downward
5	Unscrew screw (5)		For this purpose open door completely
6	Unscrew screws (6)		
7	Remove fender (7)		When replacing reassemble fender mount (7), for this purpose drill rivet heads off of pop rivets and rivet mount (7) to new fender Hand riveter
8	Install in opposite order		When installing observe correct position in relation to driver's door and engine hood, check splash guard for correct mounting, glue on if applicable
			*BR00.45-Z-1003-02A

Repair materials

Number	Designation	Order number
BR00.45-Z-1003-02A	Adhesive/Dekalin 3649	A 000 989 82 71

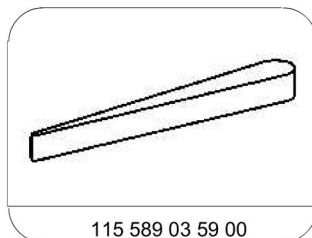

115 589 03 59 00

Long wedge