

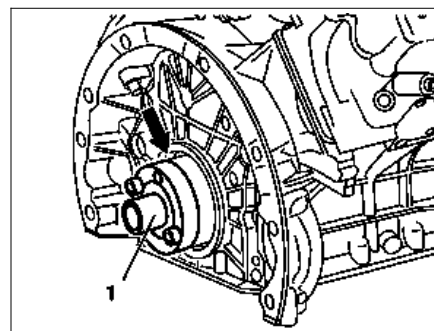

Installation tool

1 Deburr edge of mounting hole around entire circumference for rear crankshaft radial sealing ring (4) and clean mounting hole (arrow).

2 Fit internal component (1) of  installation tool to crankshaft.



P03.20-2007-01

3 Carefully push rear crankshaft radial sealing ring (4) over the internal component (1) of the  installation tool and the crankshaft journal.

 Ensure that the sealing lip (6) of the rear crankshaft radial sealing ring (4) is not damaged or compressed.

Circumference (5) and sealing lip (6) of the rear crankshaft radial sealing ring (4) as well as the mating contact surface on the crankshaft must be free of oil and grease.

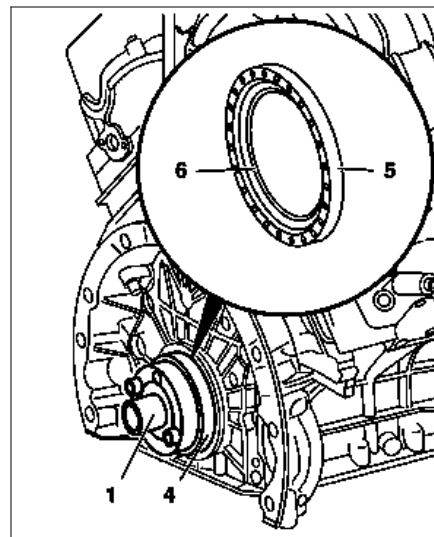

P03.20-2008-02

4 Position the outer part (2) of the  mounting tool.

 Use outer part (2) with chamfer.

5 Screw in bolt (3) until a resistance is felt.

6  Detach the mounting tool.

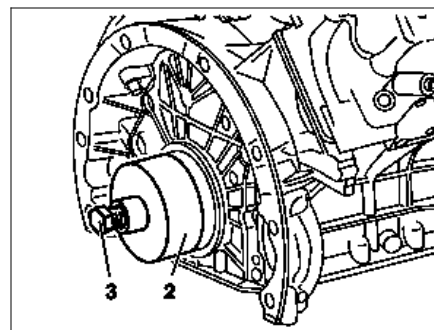

P03.20-2009-01

7 Check installation location of the crankshaft rear radial sealing ring (4) .

ⓘ The rear crankshaft radial sealing ring (4) must be positioned at right angles to the crankshaft (7) otherwise proper sealing is not assured.

**i** The clearance between the edge of the end cover (8) and the rear crankshaft radial sealing ring (4) must be approx. 1 mm (dimension a) around the entire circumference.

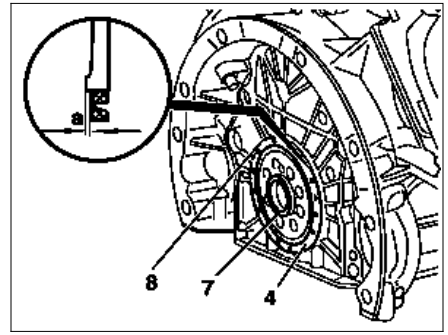

P03.20-2010-01