

158240

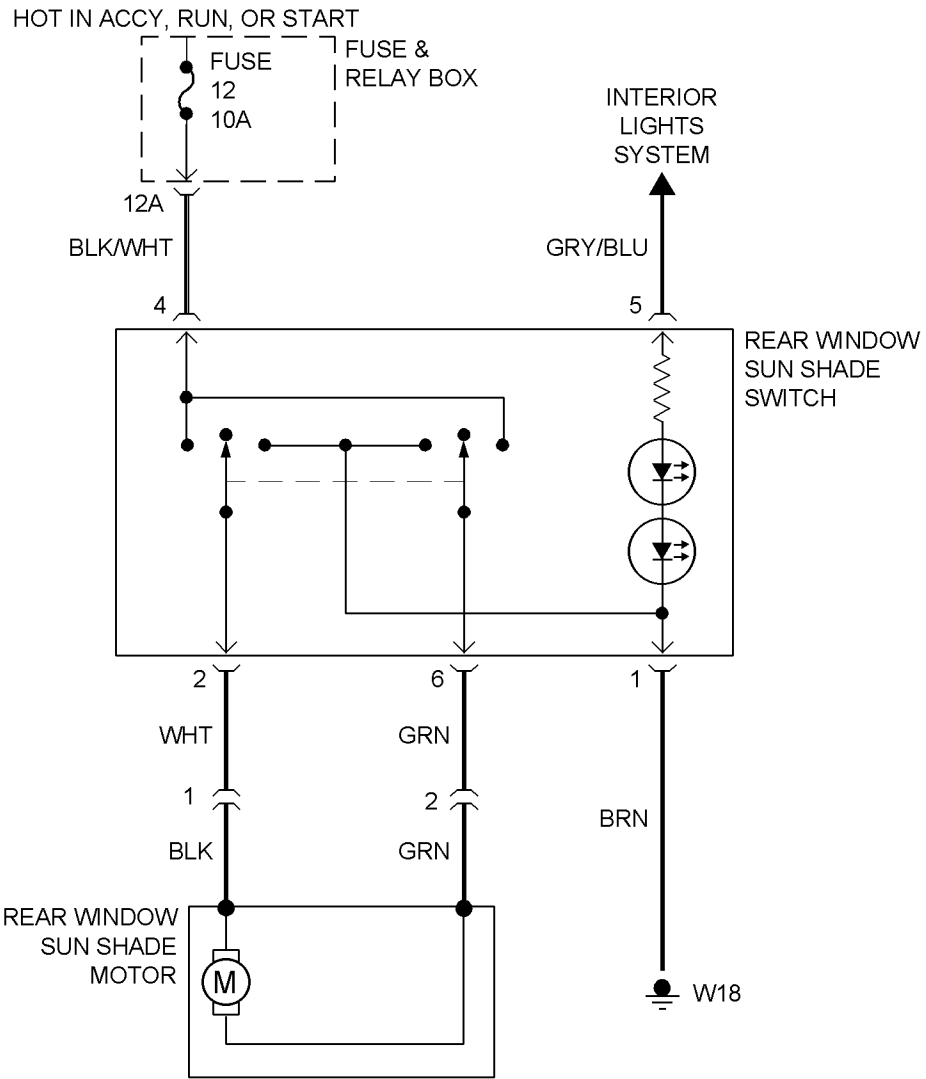

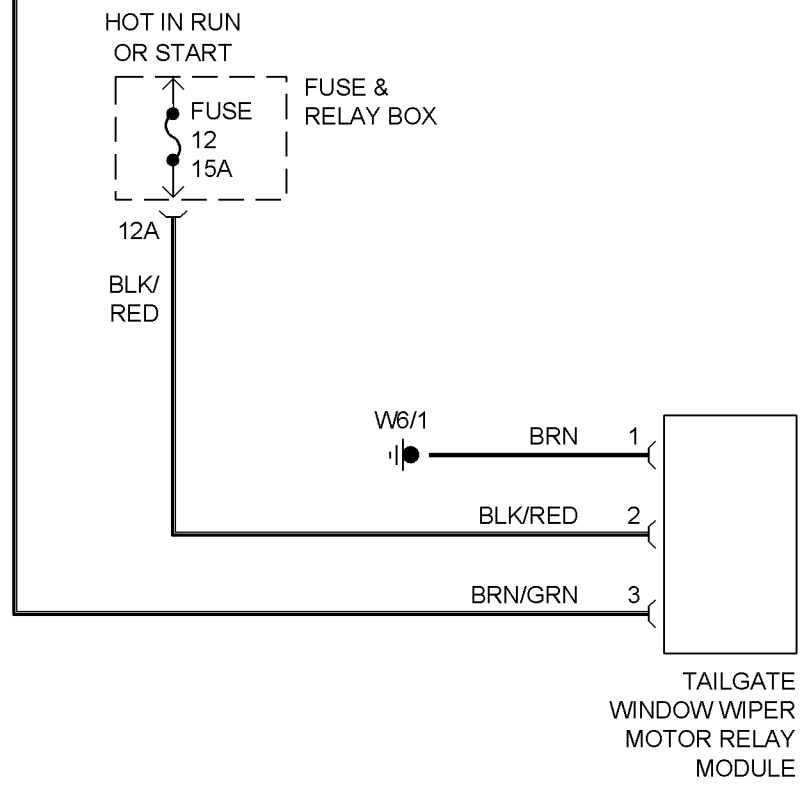

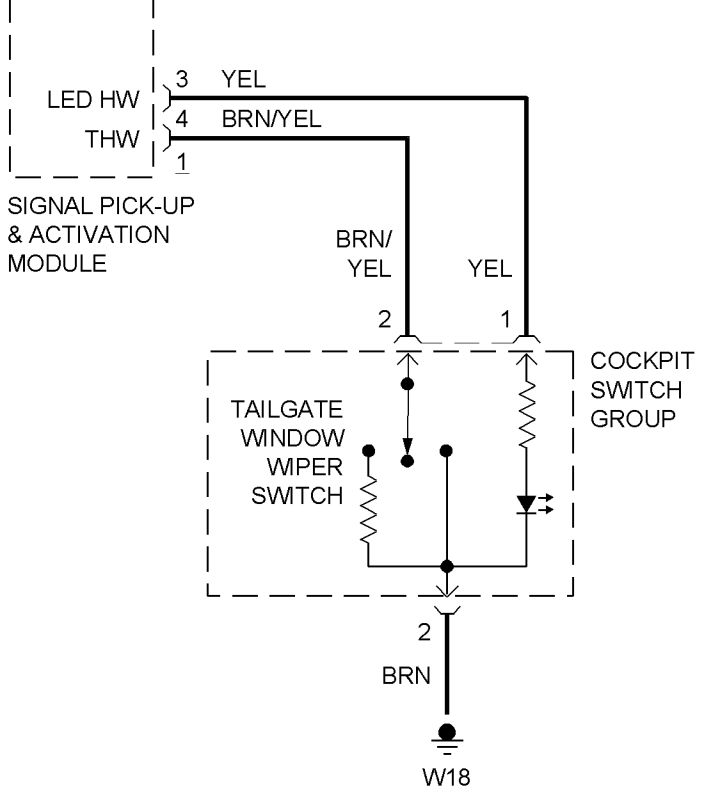

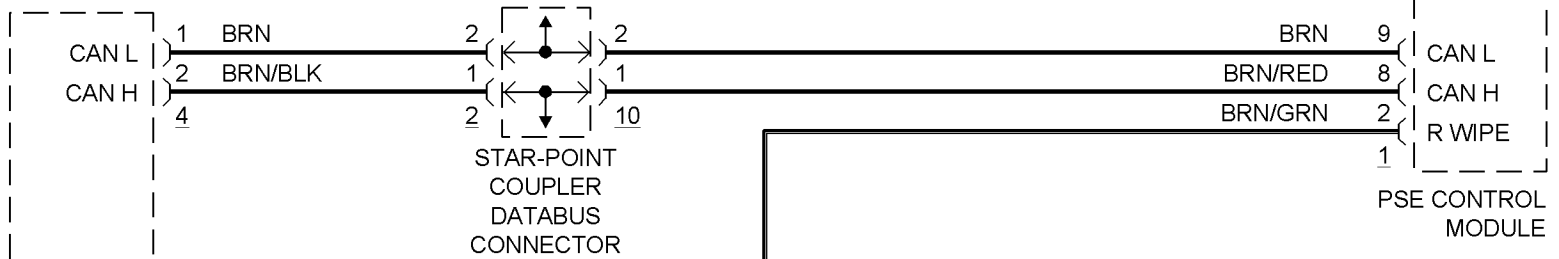
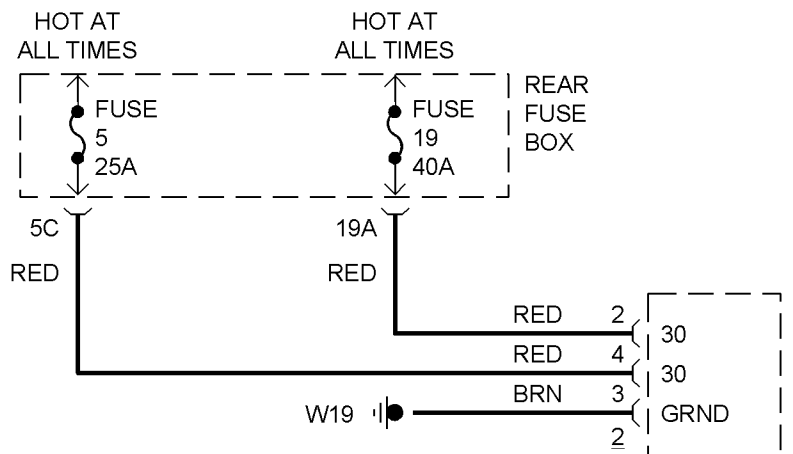
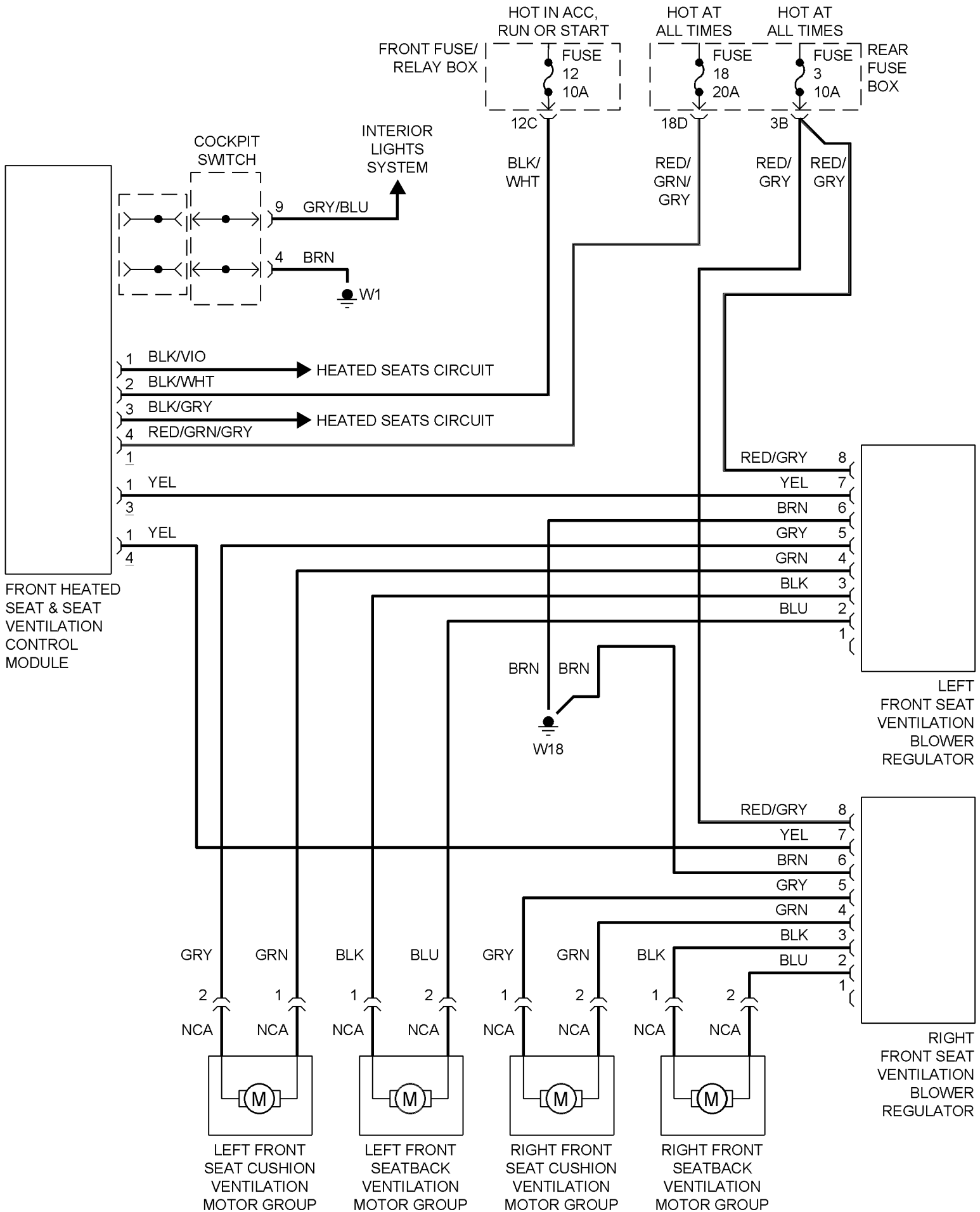
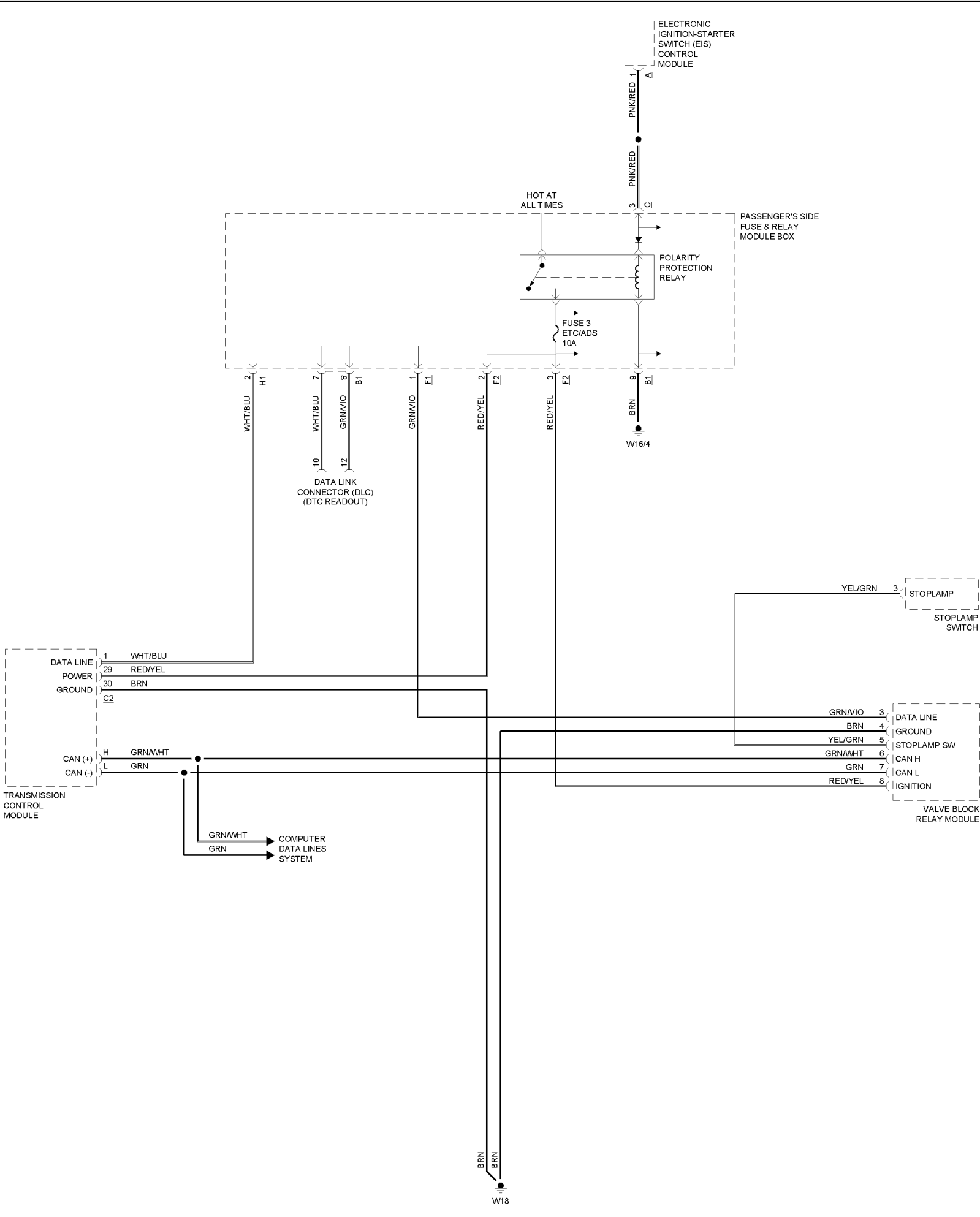

ELECTRONIC  
IGNITION-STARTER  
SWITCH (EIS)  
CONTROL  
MODULE

HOT AT  
ALL TIMES

PASSENGER'S SIDE  
FUSE & RELAY  
MODULE BOX

POLARITY  
PROTECTION  
RELAY

FUSE 3  
ETC/ADS  
10A

W16/4

DATA LINK  
CONNECTOR (DLC)  
(DTC READOUT)

STOPPLAMP  
SWITCH

DATA LINE  
GROUND  
STOPPLAMP SW  
CAN H  
CAN L  
IGNITION

DATA LINE  
POWER  
GROUND

CAN (+)  
CAN (-)

TRANSMISSION  
CONTROL  
MODULE

COMPUTER  
DATA LINES  
SYSTEM

VALVE BLOCK  
RELAY MODULE

BRN  
BRN  
W18

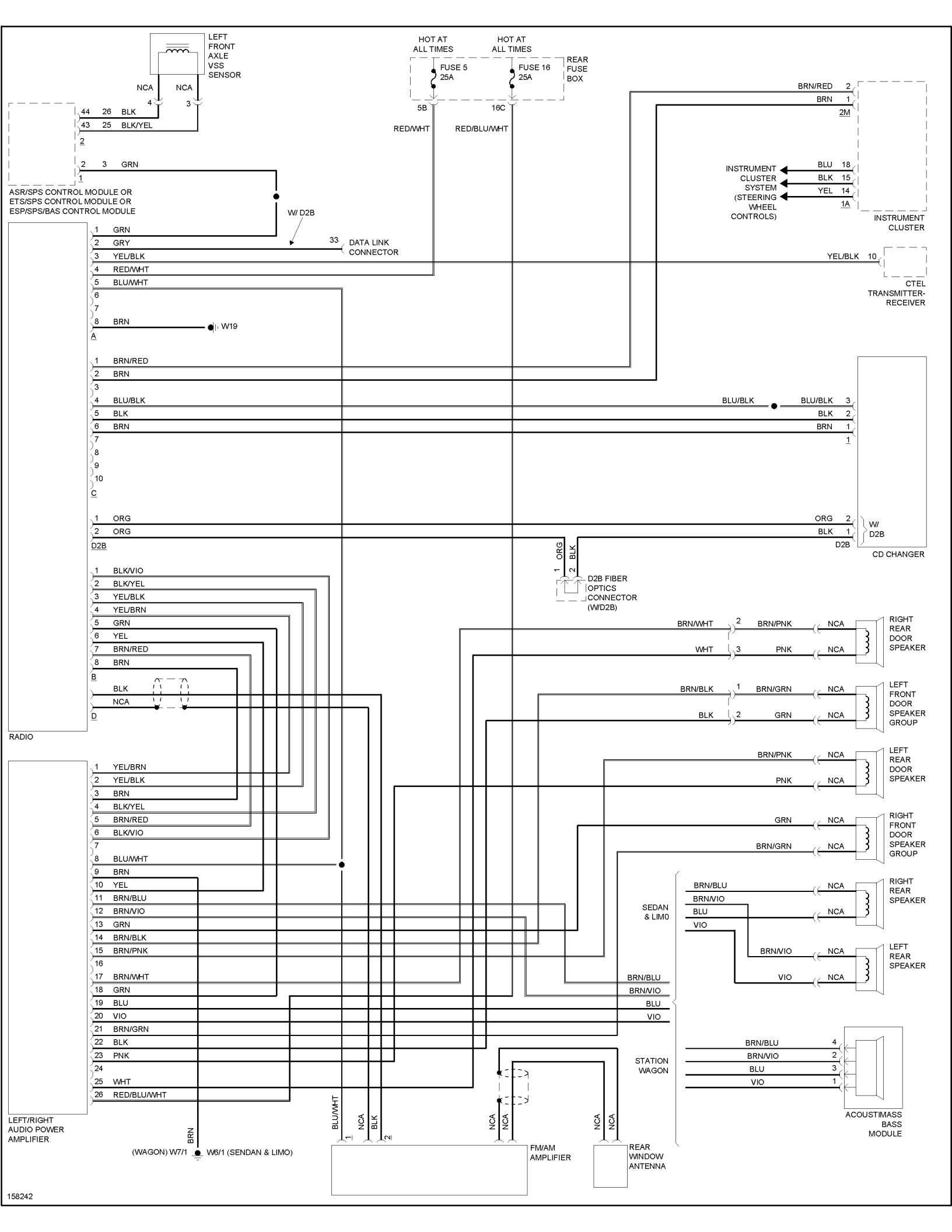

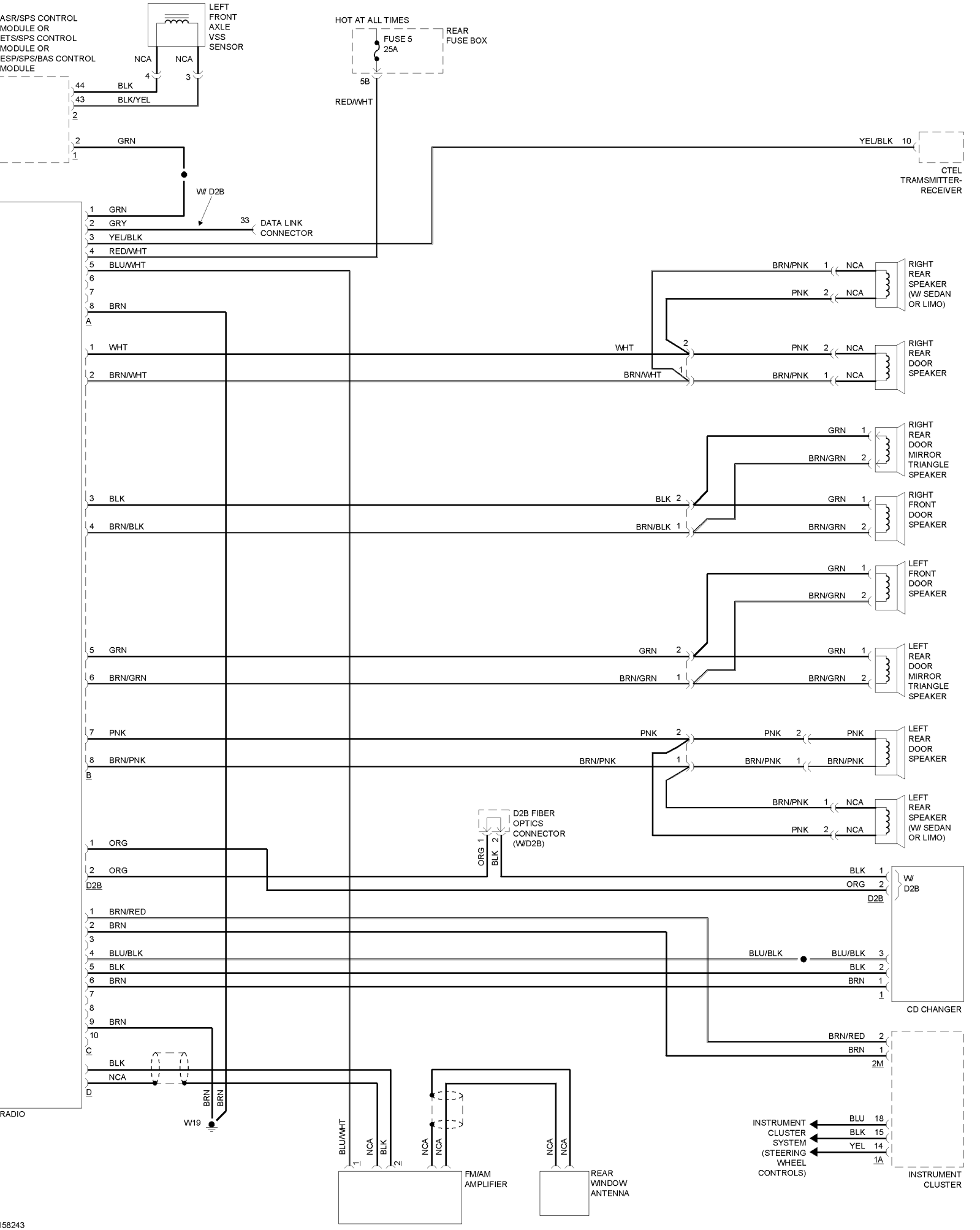



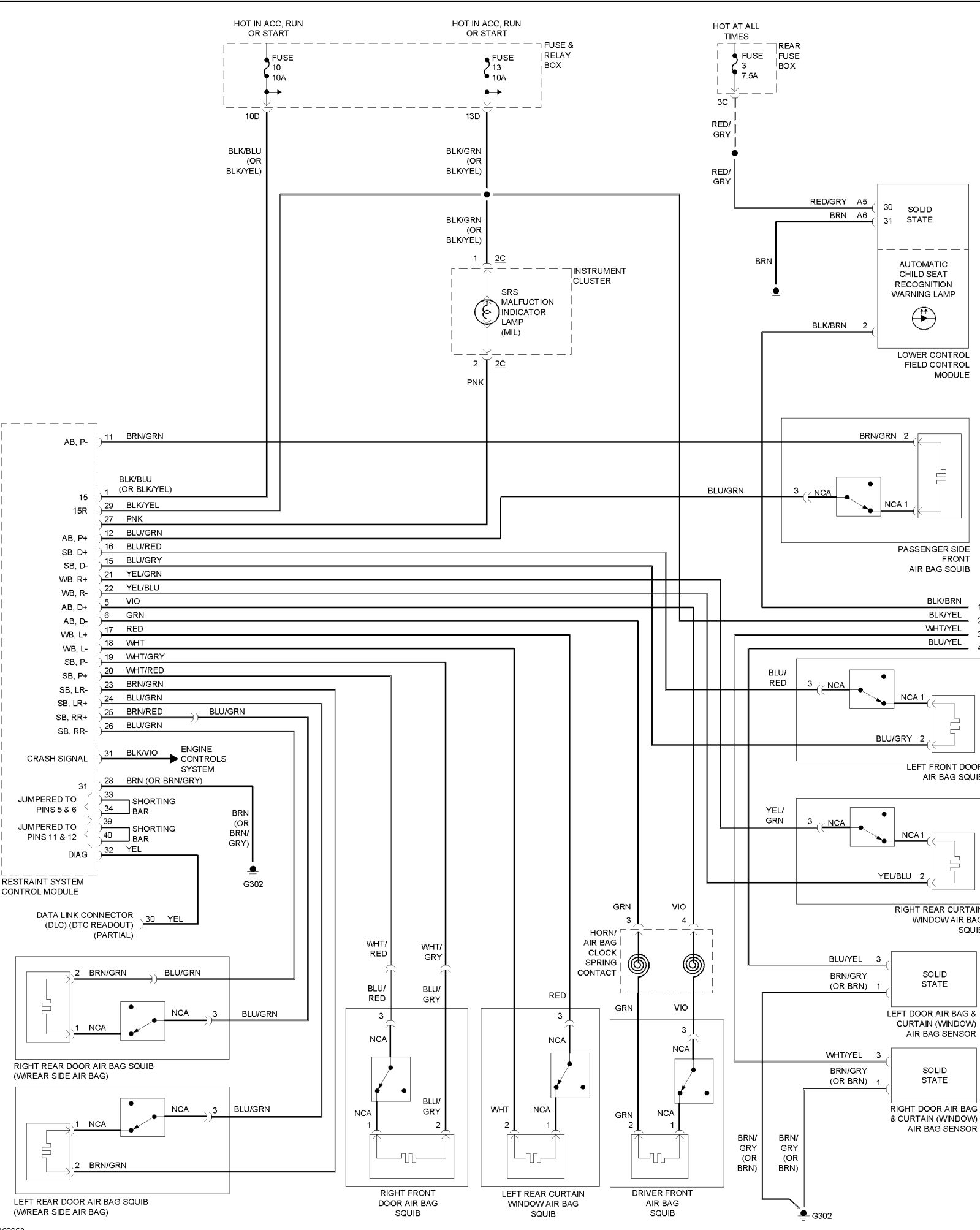

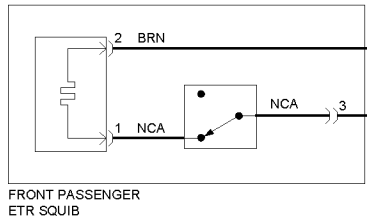
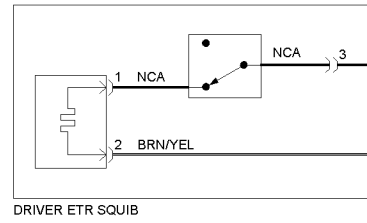

- 1 BLK/BRN
- 2 BLK/YEL
- 3 WHT/YEL
- 4 BLU/YEL

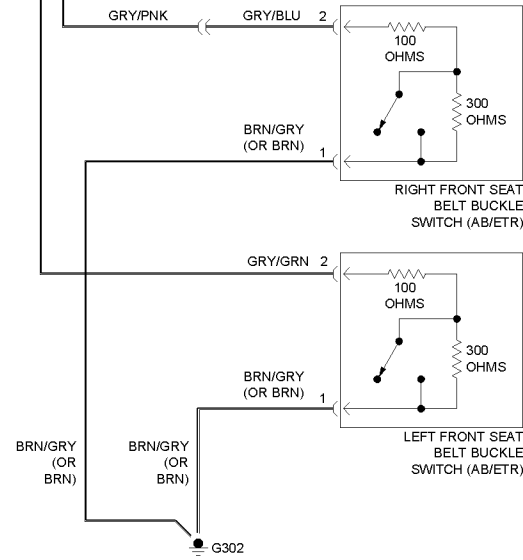
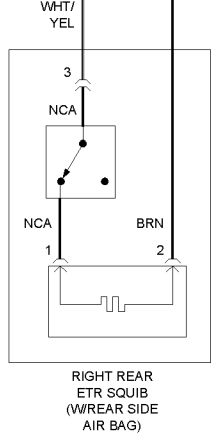
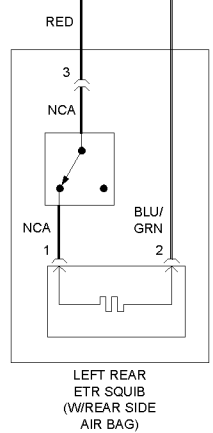
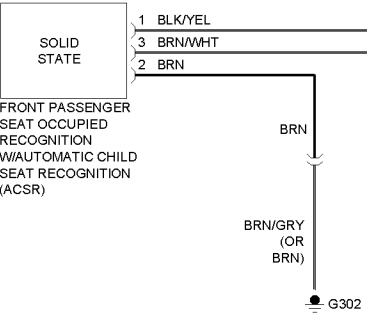

SHORTING BAR	43	JUMPERED BETWEEN PINS 15 & 16
SHORTING BAR	44	JUMPERED BETWEEN PINS 17 & 18
SHORTING BAR	45	JUMPERED BETWEEN PINS 19 & 20
SHORTING BAR	46	JUMPERED BETWEEN PINS 21 & 22
SHORTING BAR	47	JUMPERED BETWEEN PINS 23 & 24
SHORTING BAR	48	JUMPERED BETWEEN PINS 25 & 26
SHORTING BAR	49	JUMPERED TO PIN 27
SHORTING BAR	50	JUMPERED TO PIN 28
SHORTING BAR	51	
SHORTING BAR	52	
SHORTING BAR	53	
SHORTING BAR	54	
SHORTING BAR	55	
SHORTING BAR	(UN-NUMBERED PIN)	
SHORTING BAR	(UN-NUMBERED PIN)	
	56	
	57	ETR, D+
	58	ETR, D-
	59	ETR, P-
	60	ETR, P+
	61	ACSR LED
	62	ACSR
	63	SENSOR P
	64	SENSOR D
	65	ETR, LR+
	66	ETR, LR-
	67	ETR, RR+
	68	ETR, RR-
	69	D+
	70	P+

