

Automatic transmission - oil and filter change

Transmission 722.6 in MODEL 211, or other vehicles where 722.6 is used

Recommended maintenance interval 40 000 miles

Always use extreme caution when working under your car or around electrical, fuel and in some cases brake systems (SBC), or moving engine and transmission parts. If you are not confident with what you are going to do, it is always a good idea to seek help from others, or take your car to service.

Always keep your work area extremely clean to prevent debris getting inside the gearbox or the engine. Always try to have extra space around your work area. Supplies you will need:

1. **Transmission filter** – part # A 140 277 00 95 x 1
2. **Transmission gasket** – part # A 140 271 00 80 x 1
3. **Seal ring for drain plug** – part # A 140 271 00 60 x 1
4. **6 liters of MB approved ATF 3353 (236.12) or 3134 (236.14), or if you wish to proceed with torque convertor flush, you will need 15 liters of fluid.**
5. **Lock pin for transmission cap** – part # A 140-991-00-55 x 1
6. **Transmission dipstick tool** – part # A 140 589 15 21 x 1

I purchased all of my supplies from RMEuropean web site. Prices are good and they have free shipping.

Start with nicely warmed transmission, usually after at least 20 minutes' drive, but be very careful because you can burn yourself on lots of components under the car. You also can remove all panels under the car first and then take it for warm up drive.

Raise vehicle with lifting platform, or jack it up and put jack stands under the cars jacking points to support it. I usually use the jack point in the middle of the car (between radiator and engine). This way I can raise the front end and put mine jack stands at jack points under front doors. If you have one of those platforms that you drive the car on, you also can use them. I personally do not like them because when I use my creeper cart I do not have room to work.

Remove rear section of lower engine compartment paneling (vehicles with gasoline engine). After this, remove bottom engine paneling.

MODEL 211 (except 211.026)

- 1 Bolts
- 2 Front engine compartment paneling
- 3 Center engine compartment paneling
- 4 Rear engine compartment paneling

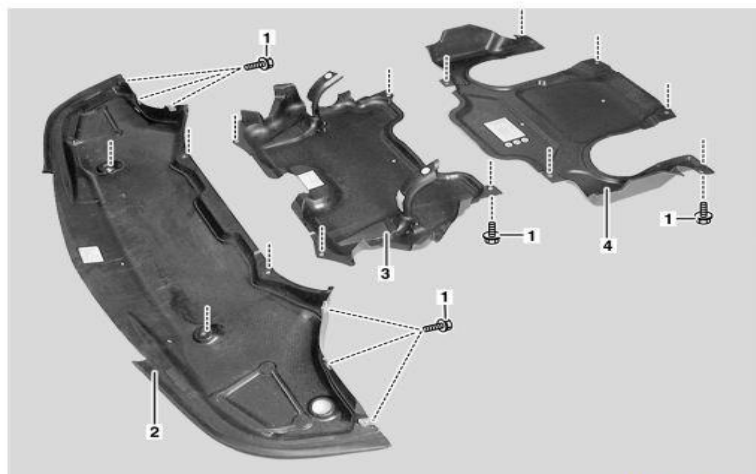

P61.20-2023-06

For vehicles with diesel engines, first remove rear part of bottom sections of soundproofing:

Rear soundproofing bottom section

1 Bolt

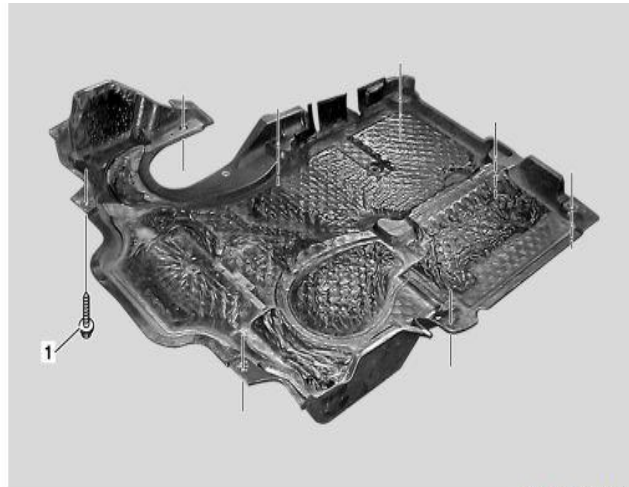

P94.30-2016-05

Remove bottom parts of noise encapsulation:

Center soundproofing bottom section

1 Bolt

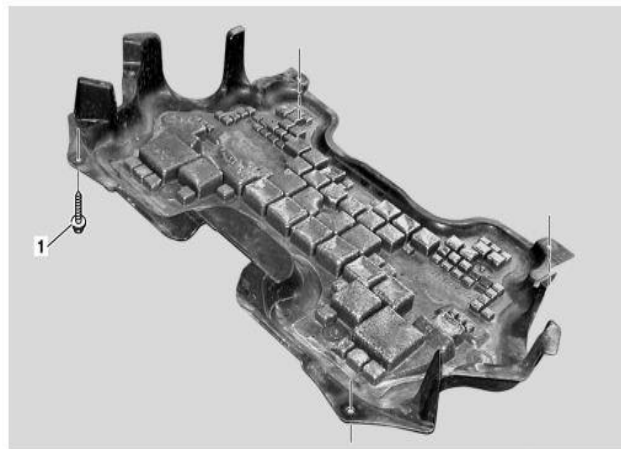

P94.30-2015-05

MODEL 211.026

Front soundproofing bottom section

1 Bolt
2 Rubber lip

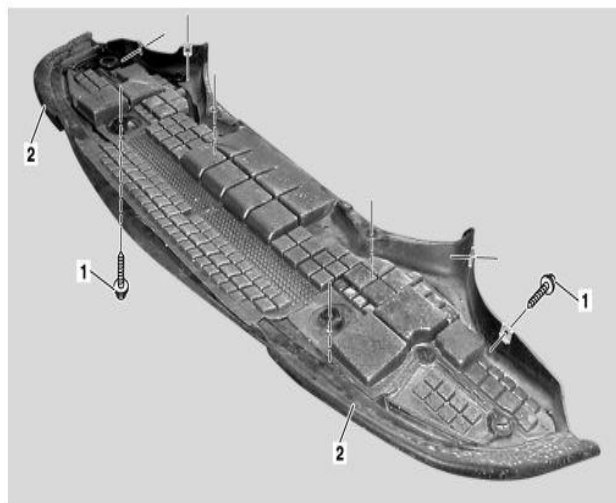

P94.30-2014-05

Unscrew oil drain screw (1) using 5mm hex bit and drain transmission oil.

Transmission 722.6 in MODEL 211

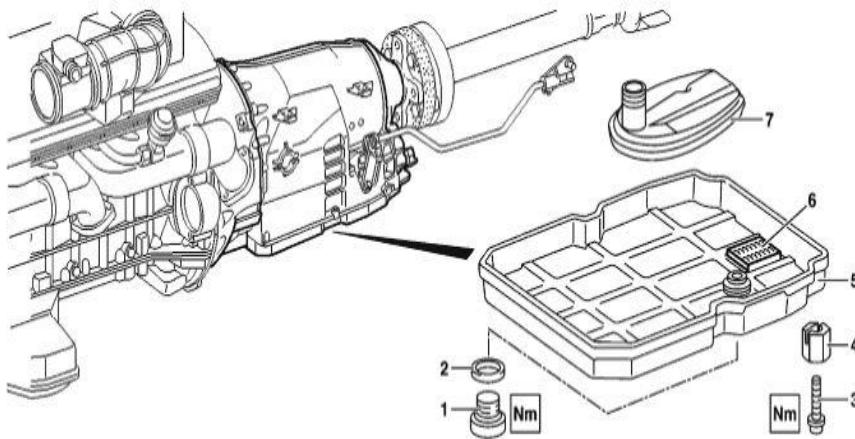

P27.00-2226-08

1 Oil drain screw
2 Sealing ring
3 Bolt

4 Sprag
5 Oil pan

6 Solenoid
7 Oil filter

If transmission oil looks burnt, or contains wear debris, flush oil cooler lines and oil cooler to prevent subsequent damage to transmission (**look at the procedure for oil cooler flushing below**).

Remove bolts (3) those required T30 bit, you may have to clean the treads with wire brush before putting them back (mine were clean because everything is enclosed w/soundproofing panels). Be careful not to burn yourself w/some oil that remains inside the pan (about 2.5 liters), or leaved hanging on 2 of the bolts on one end to allow all the oil to run out through the drain hole.

Clean the transmission oil pan and the magnet which you will find inside completely and install new gasket. If your gasket kit come w/new magnet - just replace it. Be careful not to leave any lint or fibers on inside surface of the pan.

Next thing to do is to replace the filter. Be careful when removing the old one, there is still some oil inside. Pull it down, may require some force since it has sealing ring.

Install the new filter and be sure that the sealing "O" ring is in place. Push it good in place. It fits only one way, because it has guides.

Install the pan paying attentions to the sprags (channel should engage the pans lip) and torque the screws to **8 Nm** using X pattern.

Install a new drain plug washer and torque the drain plug to **20 Nm**.

It is always a good idea to look around for leaks and damages while under the car, you will not get another shoot in next 40 000 miles.

One thing to look is the Pilot bushing part # A 203 540 02 53 (old part # A203 540 00 53). It leaks occasionally and this is why it is always a good idea to replace it. In addition, check the propeller shaft seal and you rear engine crankshaft seal (between the engine and the transmission) for leaks.

Pilot bushing A 203 540 00 53



P27.00-2253-01

I would recommend not changing Pilot bushing until you are ready to pour oil in the transmission because when it is hot you may break the plastic on the valve body where the screw tightens and then you will be in big trouble. You have to turn the big white or yellow nut on the end counterclockwise to release the cable connector. Pilot bushing has a long screw inside, which is visible after you take cable connector out; I think it was 7 mm socket, what I used. Install the new one in reverse order, do not over tight the screw holding it in place.

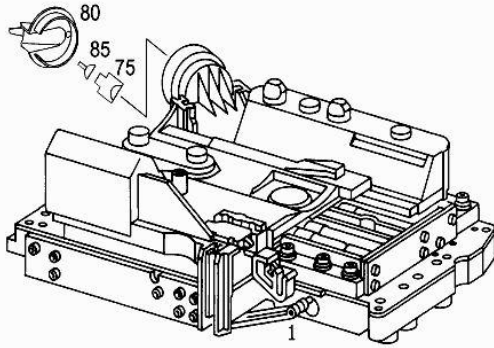

Now after you double check that all bolts and electrical connections are tight and in place you can pour in some ATF fluid. To do this you have to break the pin holding the fill tube cap in place, be careful not to drop any of those plastic pieces inside the fill tube **(right (passenger) side of the engine bay)** and press out the locking pin downwards.

Transmission 722.6 in MODEL 211

93 Cap
93a Locking pin
A 25 °C (77 °F)
B 80 °C (180 °F)

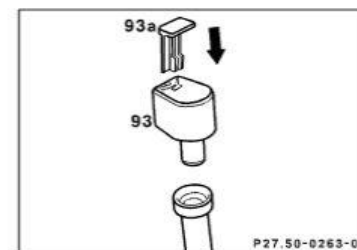
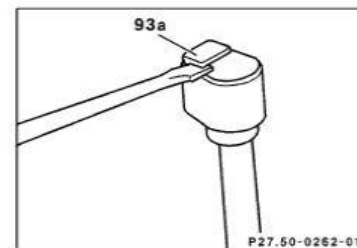
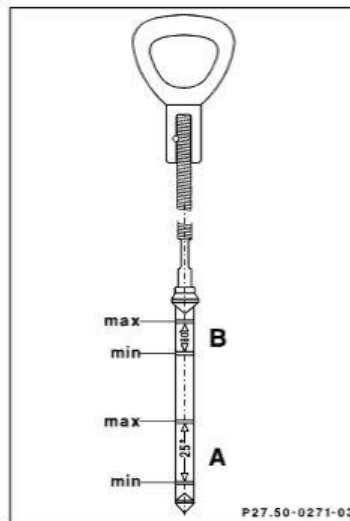

P27.50-0274-06

Pour 4 liters inside and check the level w/dipstick tool. If you wish to continue with torque convertor flush, pour in 5 liters and follow the procedure listed below. Tool

has two measuring options 25°C and 80°C. 25° is for reference only to see were the level is, actual level adjustment must be carried out at 80°, which is the working temperature of the transmission. I would add fluid until gets to the middle between min and max marks at 25°C. Start the engine and shift through the gears couple of times with parking brake on. Turn off the engine and check fluid level, add some if need to get it to the middle point at 25°C **NEVER drive the car with low ATF level.** Also, check for leaks around the oil pan, drain plug and pivot bushing.

Now put the fill tube cap, but do not install the locking pin yet. Close the hood and take your car for nice drive to warm the fluid and to check how your transmission works.

Usually if you check fluid levels after 20 minute drive should be close to the max line on the dipstick at 80°C, if not add some fluid, but do it little bit at the time. I don't have way to measure transmission temperature, so I set fluid level half way between the middle line at 80°C and the max line at 80°C, after I drove the car for 30 minutes, this way I know that fluid has some room to expand if the temp is little under 80°C or if is over 80°C, when cools down will not drop under min line.

NEVER OVERFILL OR UNDERFILL YOUR TRANSMISSION, BECAUSE THIS WILL RESULT IN TRANSMISSION DAMAGE.

I am positive that the fluid temperature will be above 80°C after 30-minute drive, unless you do this procedure in wintertime and your thermostat is not functioning properly.

Flush out oil cooler lines and oil cooler

Do this only if your transmission is been neglected for long time, or if you find debris in the oil when doing oil change, or if the oil looks burnt.

You will need pump that can switch from vacuum to pressure.

TRANSMISSION 722.6

1 Pressure fitting

2 Pump

3 Reservoir

4 Connector

A Connection direction for sucking out oil

B Connection direction for rinsing

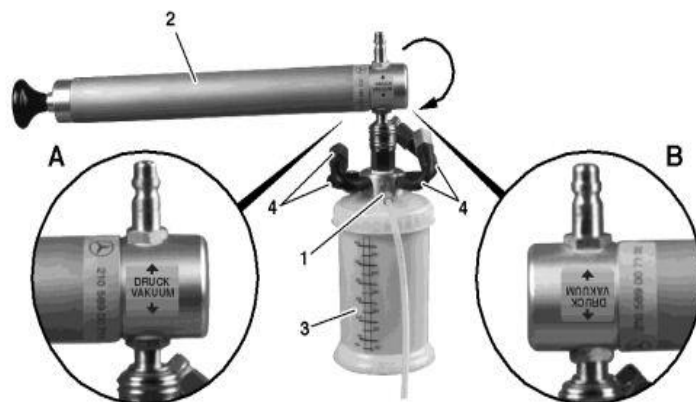

Unscrew both transmission oil cooler feed and return lines. Attach the pump to return line (coming from right side on the radiator) and collect all the oil from the cooler using vacuum. You also can use one of those oil extractors.



After this fill up the oil cooler w/kerosene through the feed line using the pressure future of the pump, be sure to have a big jug to collect the fluid running out from the return line. Do this until kerosene flows freely. Blow all of the remaining kerosene out using compressed air and flush the cooler with ATF couple of times. Connect the cooler feed and return lines to the transmission lines. **Carry out ATF level check and adjustment mentioned above.**

Flush out torque convertor and oil cooler

To do this you will need some additional supplies:

- 1. Graduated bucket that will hold at least 4 liters of fluid (I do not have one, so I used a gallon water jug, premeasured 3 liters and draw a line).**
- 2. Hose 12 mm inner diameter about five-six feet long.**
- 3. Friend to help you (you may need to buy 12-pack beer of his choice). I really prefer this one:**



After you changed transmission filter and gasket if you are going to do torque convertor flush you have to pour 5 liters of ATF into the transmission. Detach the clamps holding transmission feed line coming from the oil cooler (**on right (passenger) side of the engine**) and unscrew banjo bolt (3) from connection. Connect connection fitting (4) with an approx. 1.5-meter long hose using hose clamp (5). Mount banjo bolt (3) and oil cooling line (2) to connection fitting (4). I do not know where you can find connection fitting or the part # for it, but you can try to slip the hose on the bolt and tight it with hose clamp. After this try holding the hose clamp with pliers and tight the bolt little bit more. There is no pressure when the fluid flows, so hopefully will run through the hose. Hold hose in a bucket with a scale. Bucket should hold at least 4 liters of fluid.

- 1 Oil cooling line connection
- 2 Right oil cooling line
- 3 Banjo bolt
- 4 Connector
- 5 Hose clamp

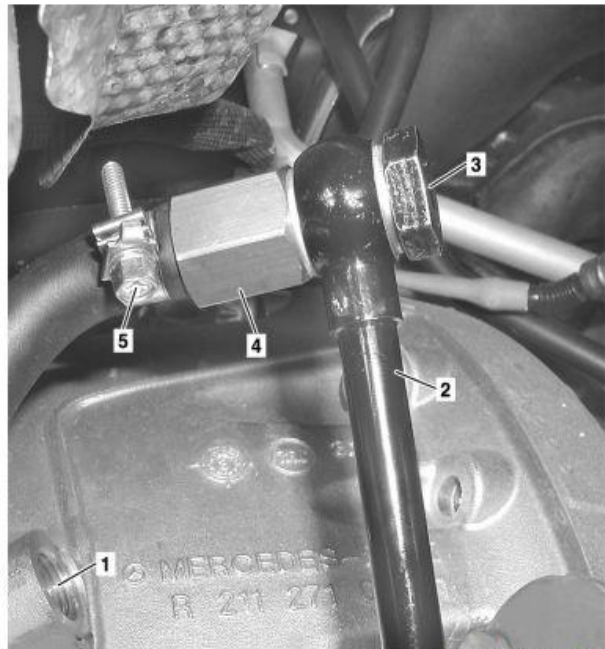

P27.55-2048-12

Banjo bolt tightening torque to the transmission is 5 Nm on stage1 plus 95° stage 2. Line clamp bolt tightening torque is 8 Nm.

- 1 Oil cooling line connection
- 2 Right oil cooling line
- 3 Banjo bolt

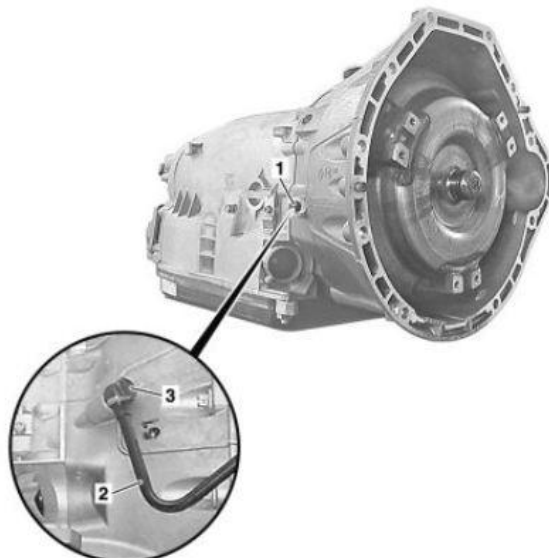

I did something different: I disconnected the fitting between the metal line going to the

transmission and flexible hose coming out of the oil cooler **(on right (passenger) side of the radiator)**. After this, I connected the flush hose to the cooler discharge line fitting and tied it w/zip tie. Loose the banjo bolt a little bit, if you want, that way all remaining fluid in the cooling line will drain out.

Now tell you friend, or the person helping you to start the car. Watch the fluid coming out of the hose, you should run out 3 liters, so watch the fluid level as it gets close to the 3-liter line they will have to shut off the engine. When I did the flush, I was not able to run out 3 liters of fluid. Bubbles will start coming out after 2.5-liter mark. Add 3 liters or the amount you flush out according to the measurement, of fluid to the transmission. Repeat flushing process two more times. Pour in remaining transmission oil (3 liters) and check transmission oil level.

It is little confusing about the liters of fluid that you need to be adding, but here is the math:

5 liters initial fill after drain and filter replacement, plus

3 liters after first flush (after you ran out 3 liters), plus

3 more liters after second flush (you ran out 3 more liters), plus

3 more liters after third flush (you ran out 3 more liters) for final fill.

All adds to 14 liters. Fifteenth bottle is for topping off or in case, you spill something.

Drain 5 liters/add 5 liters, run out 3 liters/add 3 liters, run out another 3 liters/add 3 liters, run out 3 more (FINAL) liters/add 3 liters = 14 liters.

Now carry on level check/adjusting procedure mentioned above. After you set the fluid level, you can install all undercarriage panels and do not forget to check for leaks one final time.