

Illustrated on left rear shock absorber

- 1 Spring control arm
- 41 Air spring
- 72c Cover
- 75 Shock absorber
- 75a Nut
- 75b Washer
- 75i Upper rubber mount
- 75k Lower rubber mount

- X62/8 Rear axle multiple circuit junction connector

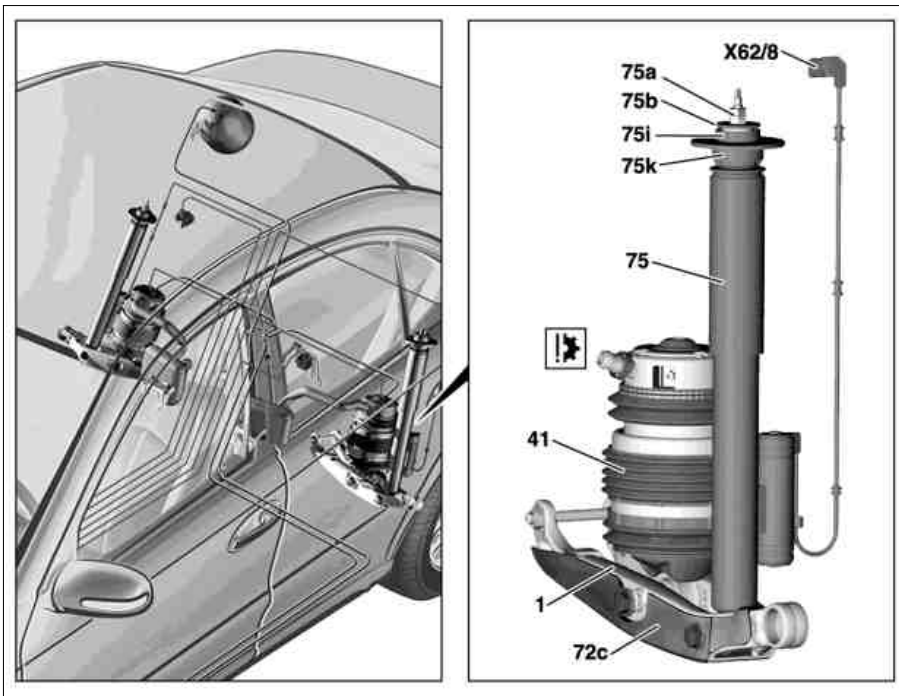





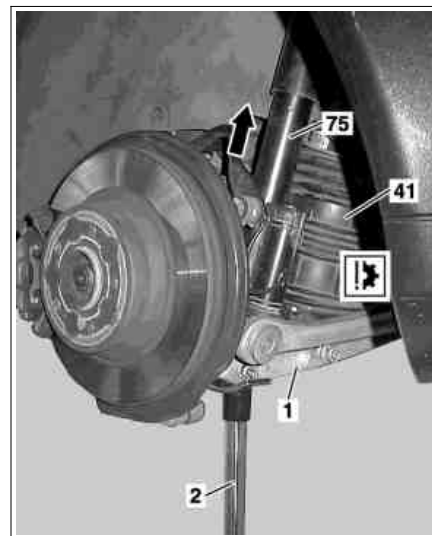



P32.22-2156-06

- 1 Spring control arm
- 2 Transmission jack
- 41 Air spring
- 75 Shock absorber



P32.25-2071-02

	Remove/install		
Danger!	Risk of injury caused by moving parts that can pinch, crush or , in extreme cases even sever extremities.	Keep body parts and limbs well clear of moving parts.	AS00.00-Z-0009-01A
	Notes on self-locking nuts and bolts		AH00.00-N-0001-01A
	While working on the rear axle, care must be taken to ensure that the surface of aluminum components do not get any scratches, cracks and notches. Otherwise the service life of the parts will be affected		
Installation	Tighten nuts and bolts of chassis components only when vehicle is in the ready-to-drive condition.		
1	Remove side paneling in trunk	With through-loading feature code 287 without through-loading feature	AR68.30-P-4800TA AR68.30-P-4800T
2 	Remove rear wheel Remove and install wheels		AP40.10-P-4050Z
3	Remove inner fender from rear fender		AR88.10-P-1400T
4	Unplug rear axle multiple circuit junction		AR32.22-P-1500-01TH

5	Remove cover (72c) of spring control arm (1)		
6	Discharge to residual pressure in air spring (41) using STAR DIAGNOSIS and immediately raise spring control arm (1) roughly 30 mm using  transmission jack (2) Special information on AIRmatic	 The air spring should not be fully expanded or upset as this would cause irreparable damage.   Installation: The filling process of the air spring should be observed otherwise it will be destroyed:	AR32.22-P-1500-04T AH32.22-P-1000-02T *WE58.40-Z-1030-11A AR32.22-P-1500-03T
7	Counterhold piston rod and unscrew nut (75a)		*BA32.25-P-1003-03G
8	Remove washer (75b) and upper rubber mount (75i)		
9	Detach shock absorber (75) from spring control arm (1)		*BA32.25-P-1002-03G
10	Push together shock absorber (75) (arrow) and remove backwards		
11	Remove lower rubber mount (75k)		
	Checking		
12	Check upper and lower rubber mounts (75i, 75k)	 Replace cracked, oiled and deformed rubber mounts.	
13	Check shock absorber (75) for damage	Replace if necessary.	
14	Install in the reverse order		

Rear axle shock absorber

Number	Designation				Model 211.0 with code 489a AIRmatic
BA32.25-P-1002-03G	Self-locking nut to spring control arm shock absorber	M10	Stage 1	Nm	50
			Stage 2	△°	90
BA32.25-P-1003-03G	Nut for attaching shock absorber to frame floor	M10		Nm	20

Workshop equipment

WE58.40-Z-1030-11A	Transmission jack
--------------------	-------------------