

MODEL 129, 140, 170, 202, 203, 208, 209, 210

MODEL 211.004 /006 /016 /023 /026 /028 /042 /043 /056 /061 /065 /070 /076 /080 /082 /083 /087 /206 /216 /2 23 /226 /242 /243 /256 /261 /265 /270 /276 /280 /282 /283 /287 /606 /616

MODEL 215.373 /374 /375 /376 /378 /379

MODEL 220.025 /026 /028 /063 /065 /067 /070 /073 /074 /075 /083 /084 /087 /125 /126 /128 /163 /165 /167 /1 70 /173 /174 /175 /176 /178 /179 /183 /184 /187 /875 /878

MODEL 230.467 /474 /475 /476 /479

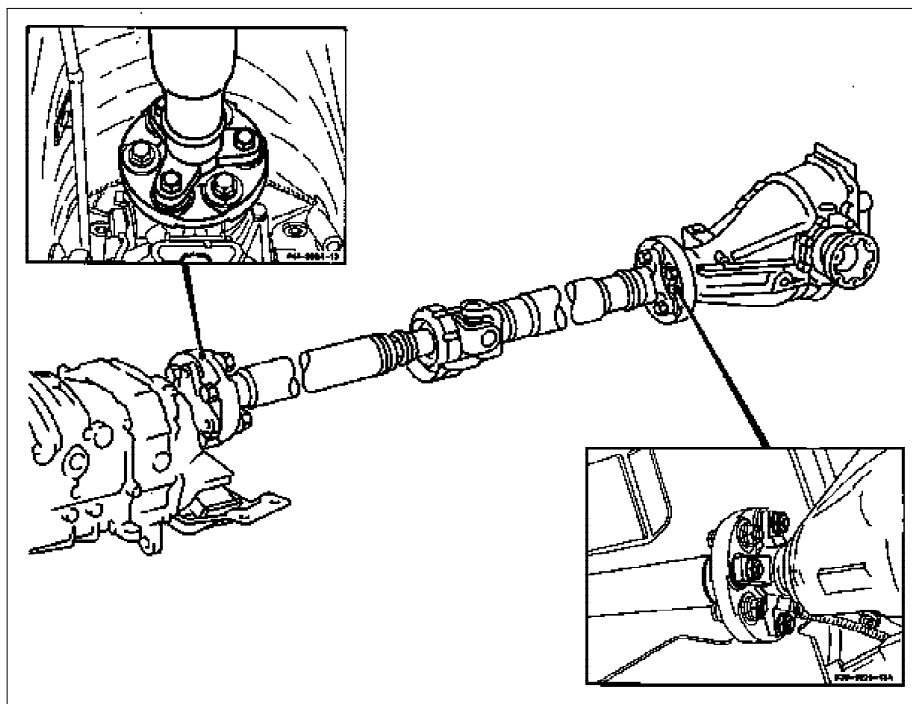

P41.10-0037-06

☐	Check		
⚠ Danger!	Risk of death caused by vehicle slipping or toppling off of the lifting platform.	Align vehicle between the columns of the hydraulic hoist and position the four support plates below the hoist support points specified by the vehicle manufacturer.	AS00.00-Z-0010-01A
1	Raise vehicle with lifting platform		
2	Check flexible couplings and vibration damper for wear, damage and deformation	<p>ⓘ If defects are found during the visual inspection: # Replace the flex disk and/or vibration damper on a separate invoice.</p>	
3.1	Check spacers of flexible coupling in vicinity of fitted sleeves for cracks and permanent deformation	<p>ⓘ Only on vehicles with flex disks with flexible thrust response mounted at transmission end. ⓘ If defects are found during the visual inspection: # Replace the flex disk on a separate invoice.</p>	AP41.10-P-4152-01ZA
4	Check spacers of vibration damper for cracks	<p>ⓘ If defects are found during the visual inspection: #</p>	AP41.10-P-4152-02ZA
		Replace the vibration damper on a separate invoice.	

- 1 Check spacers in vicinity of fitted sleeves (arrows) for cracks (visual inspection).
- 2 If the event of deformation, relieve the stress on the propeller shaft.
i If tears or permanent sets are present, the flex disk must be replaced on a separate invoice.

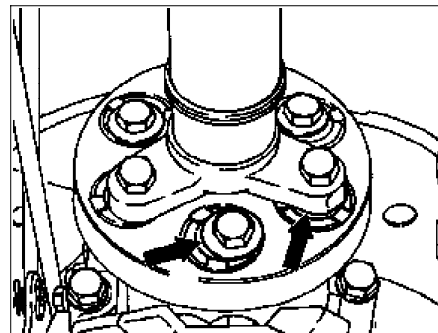

- 1 Check spacers (arrows) of vibration damper for cracks (visual inspection).

i If there are cracks in the intermediate webs, replace the vibration damper against a separate order.

