

MODEL 129, 140, 163, 202, 208, 209, 210, 211, 215, 220, 240

MODEL 203, 230 up to Model Year 08 /modification year

- 1 Brake drum
- 2 Band spring
- 3 Gearing
- 4 Notch
- 6 Spring
- 71 Pedal assembly
- 75 Brake pedal

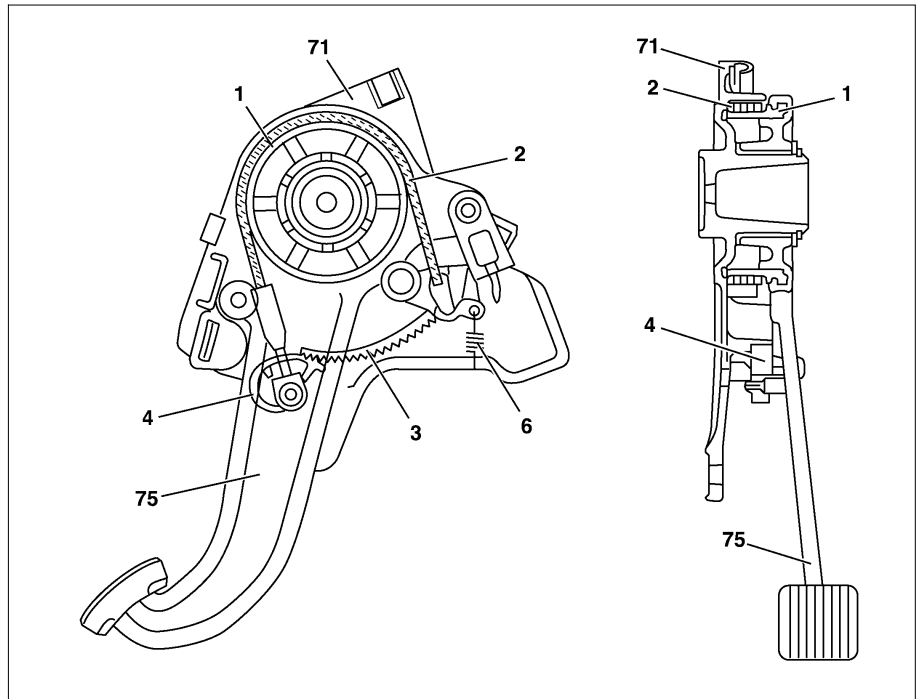

P42.20-0229-06

	Task	To hold the brake pedal (75) of the parking brake in the pressed position and avoid loose knock.	
	Function	<p>A brake drum (1) is cast into the brake pedal (75). A pre-compressed flat spiral spring (2) is wound around this drum (1). The flat spiral spring is pre-compressed by a spring (6).</p> <p>If the brake pedal (75) is pressed, the force of friction of the flat spiral spring (2) continuously holds the brake pedal (75).</p> <p>When the pedal is pressed the familiar adjusting noise is passed on via the tothing (3) and the notch (4).</p>	