

FILE: SERVICE: GROUP 00 OF SERVICE INFORMATION BINDER
PARTS: GROUP I OF INFORMATION – PARTS & ACCESSORIES BINDER

Campaign No. 2005110001, May 2006

Revision History

Revision	Date	Purpose
F	05/05/06	Update of warranty information for SBC unit replacement
E	04/26/06	Addition of SBC hydraulic unit part number for model 219
D	04/05/06	Addition of 3 new non-campaign damage codes for SBC unit replacement
C	01/12/06	Update of SBC connector information and clarification of SBC unit part numbers
B	12/21/05	Update of warranty information
A	12/13/05	Update of warranty and model year information
-	12/06/05	Initial issue

TO: ALL MERCEDES-BENZ CENTERS

SUBJECT: **MODEL 211, MODEL YEAR 2003-2006**
MODEL 219, MODEL YEAR 2006
MODEL 230, MODEL YEAR 2003-2005
INSTALLATION OF GROUND WIRES AND BRACKET TO SBC WIRING HARNESS

This Recall Campaign has been initiated because DCAG has determined that on the affected vehicles (see VIN range on the following page) the SBC brake system may shift to the hydraulic back up mode due to the loosening of the ground wire harness connection over time. Dealers will install a bracket and replace the ground wire.

Note:

This recall campaign is divided into two separate Procedures:

- I **MODELS 211/219**
INSTALLATION OF GROUND WIRES AND BRACKET TO SBC WIRING HARNESS (PAGES 3-19)
- II **MODEL 230**
INSTALLATION OF GROUND WIRES AND BRACKET TO SBC WIRING HARNESS (PAGES 20-34)

Note:

With the launch of this campaign, 211 and 230 vehicles subject to last year's SBC Recall Campaign No. 2004050014 that have not been repaired to date have been excluded from last year's campaign and will no longer appear in VMI as an "Open" campaign. All vehicles subject to last year's SBC recall, both "Open" and "Closed" will be campaigned under this year's SBC campaigns.

Please review the Effective Serial Number Chart located on the following page.

Attached is a sample copy of a letter which owners of the affected vehicles will receive.

Prior to performing this Recall Campaign:

- Please check VMI to insure the vehicle is involved and to determine if the vehicle has been previously repaired.
- Please review the entire Recall Campaign bulletin.

Approximately 194,828 vehicles are involved.

Order No. P-RC-2005110001

This bulletin has been created and maintained in accordance with MBUSA-SLP 5.1, Document and Data Control, and MBUSA-SLP 16.1, Control of Quality Records.

Effective Serial Number Range

Models	Chassis End Number	
	From	To
211.026	A178744	A791926
211.056	A774034	A791985
211.065	A014562	A734487
	X097815	X116123
211.070	A042945	A791708
211.076	A136286	A791963
211.082	X108074	X180208
211.083	X108399	X185352
211.087	X177825	X185353
211.256	A710773	A791204
211.265	A307691	A732056
211.276	A715663	A789757
211.282	X108182	X178465
211.283	X108624	X185282
211.287	X174229	X185332
219.375	A000205	A025146
219.376	A007370	A024951
230.474	F009458	F105503
230.475	F001748	F105612
230.476	F053823	F105527
230.479	F081688	F105355

Note:

Every vehicle in the VIN range may not be included in the campaign. VMI must always be checked before performing campaigns to verify that the campaign is required on a specific vehicle. VMI **always** overrides the bulletin in reference to a specific vehicle's inclusion in a particular campaign. Please also note that Recall and Service Campaigns **do not expire** and may also be performed on a vehicle with a vehicle status indicator.

I MODELS 211/219

INSTALLATION OF GROUND WIRES AND BRACKET TO SBC WIRING HARNESS

Procedure

A. INSPECTION OF BRACKET AND MOUNTING BORES

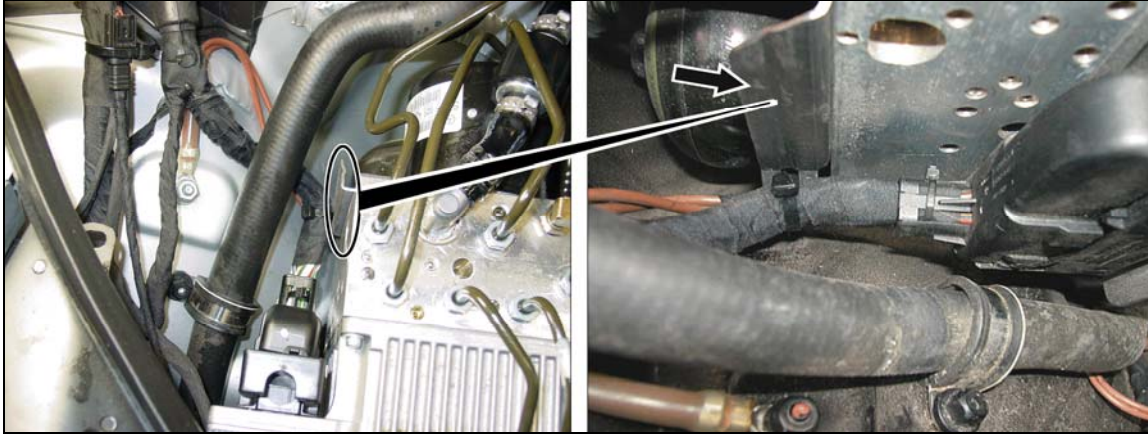

Figure 1

1. Open hood.
2. Check if bracket (arrow, Figure 1) is installed on the SBC hydraulic unit:
 - If bracket (arrow) **is installed**, proceed to Subject **B**, step 22: Check software release.
 - If bracket (arrow) is **not installed**, proceed to next step.
3. Check for bracket mounting bores (arrows Figure 2) in the SBC hydraulic unit:
 - If bores are **not** present, a clamp-on harness mounting bracket must be installed. Proceed to Subject **B** and complete the procedure in its entirety.
 - If bores **are** present, proceed to subject **B** and do not perform step 18: Installation of clamp-on mounting bracket.

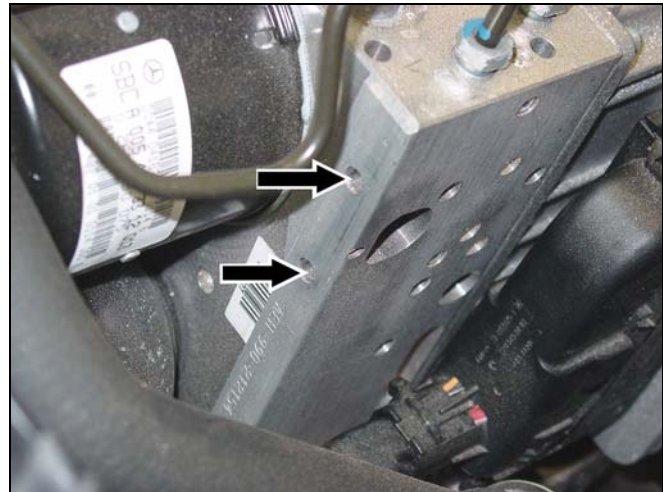

Figure 2

P00.00-0000-00

B. INSTALLATION OF GROUND WIRES AND BRACKET TO SBC WIRING HARNESS

1. Lock the vehicle globally and then wait for 30 seconds for the SBC control module to power-down.
2. Loosen hose mounting strap (A, Figure 3) and reposition hose and strap (A) to create more working space.
3. Disconnect harness connector (C, Figure 3) from the SBC hydraulic unit (D).
4. Detach the SBC hydraulic unit ground wire (arrow, Figure 3) at ground terminal (B).
5. Remove cable tie (arrow, Figure 4) securing SBC wire harness (A) to SBC connector housing (B).

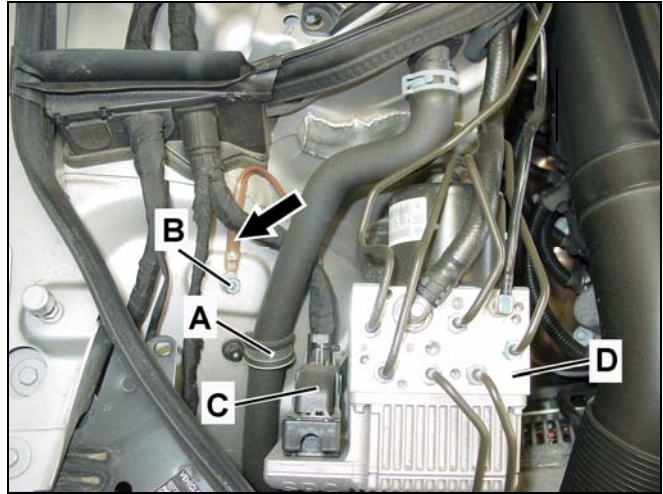

Figure 3

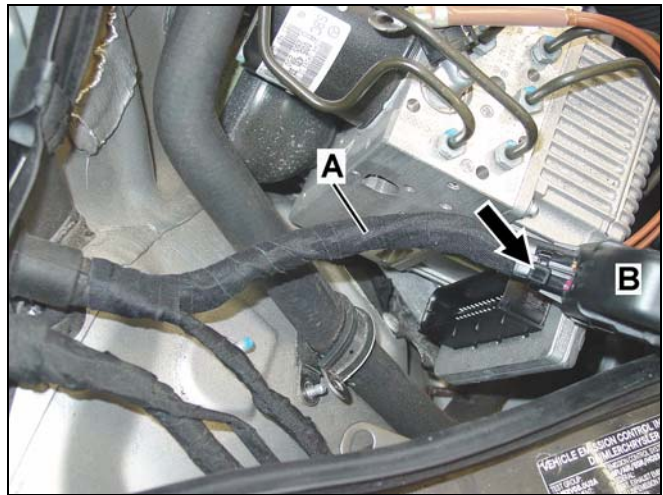

Figure 4

6. Remove fabric tape (circled area, Figure 5) from wire harness up to rubber grommet.

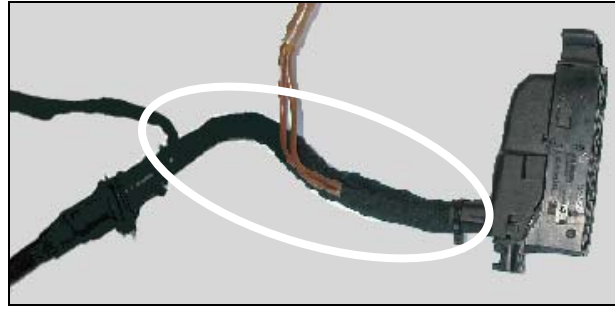

Figure 5

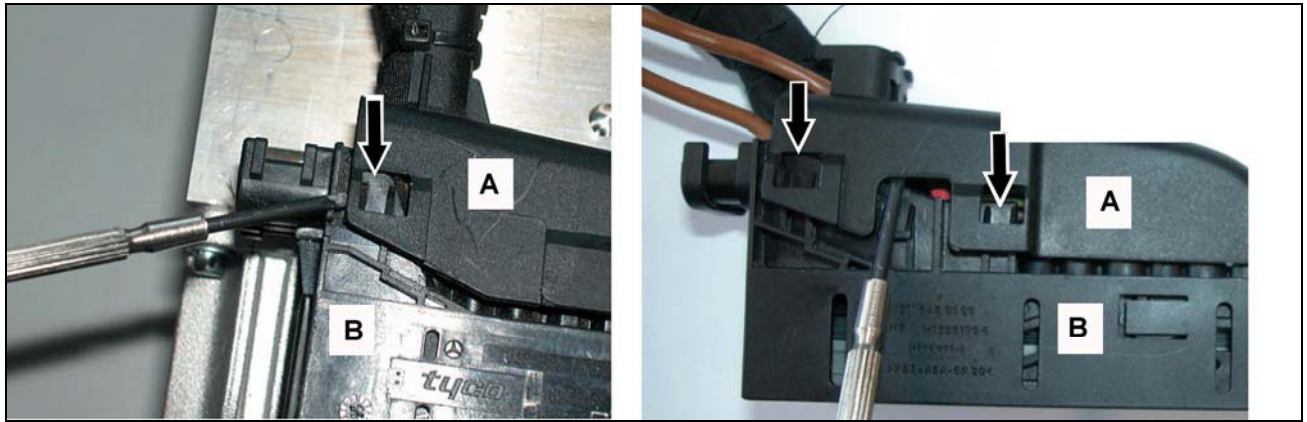

Figure 6

7. Remove SBC connector housing cover (A, Figure 6):
- Using a small screw driver, carefully pry cover (A) away from locking lugs (arrow) until it disengages.
 - Repeat the process on opposite side.
 - Remove the cover (A) from the housing (B).

Note:

There are two different versions of the SBC wiring harness connector (Figure 7a, b) installed in vehicles involved with this campaign.

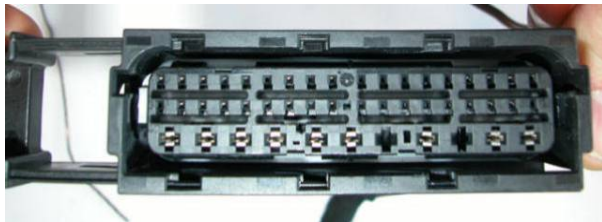

Figure 7a (Connector Type A)



Figure 7b (Connector Type B)

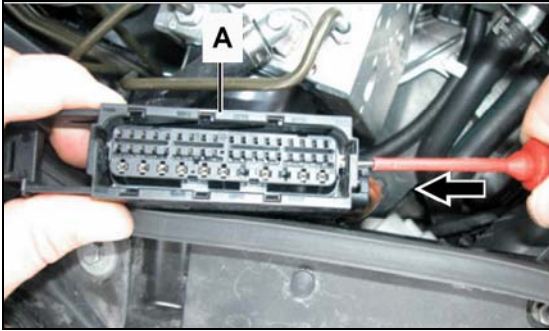

Figure 8a (Connector Type A)

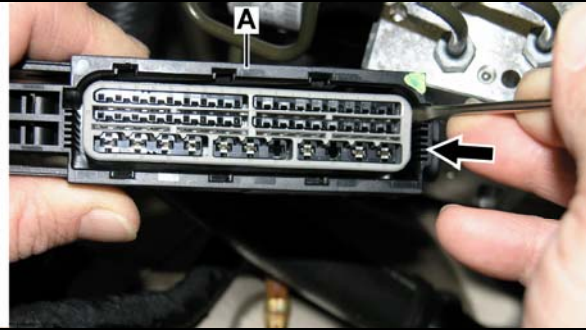

Figure 8b (Connector Type B)

8. Open the (gray) secondary lock in the SBC connector housing (A, Figure 8) by sliding the lock in the direction indicated by the arrows (Figure 8) using a small screwdriver.

9. Remove SBC ground wires (arrows, Figure 9) from SBC harness connector (A):
- Unpin ground wire connectors (position 37 and 44) using cable release tool and remove from SBC connector housing (A) (special tool nos.: W 000 589 13 99 30 and W 220 589 01 99 50).
 - Discard old ground wiring harness; it is no longer needed.

10. Insert the new ground wire harness (arrows Figure 9) into the SBC connector housing (A):
- Insert **longer** ground wire into position 44.
 - Insert **shorter** ground wire into position 37.

Note:

Ensure ground wire connectors are **properly** locked into place.

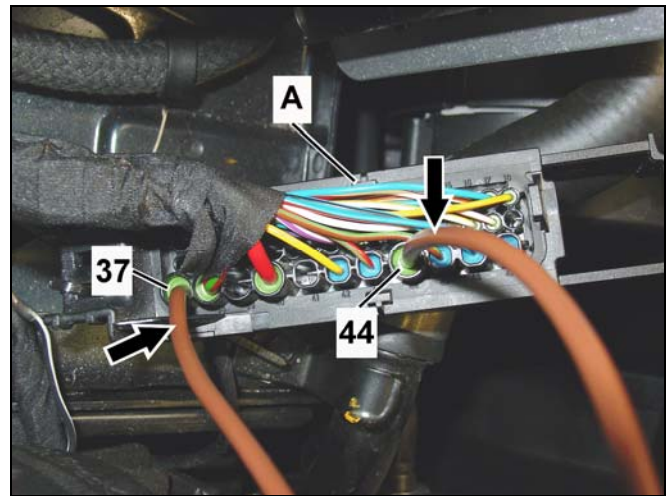

Figure 9

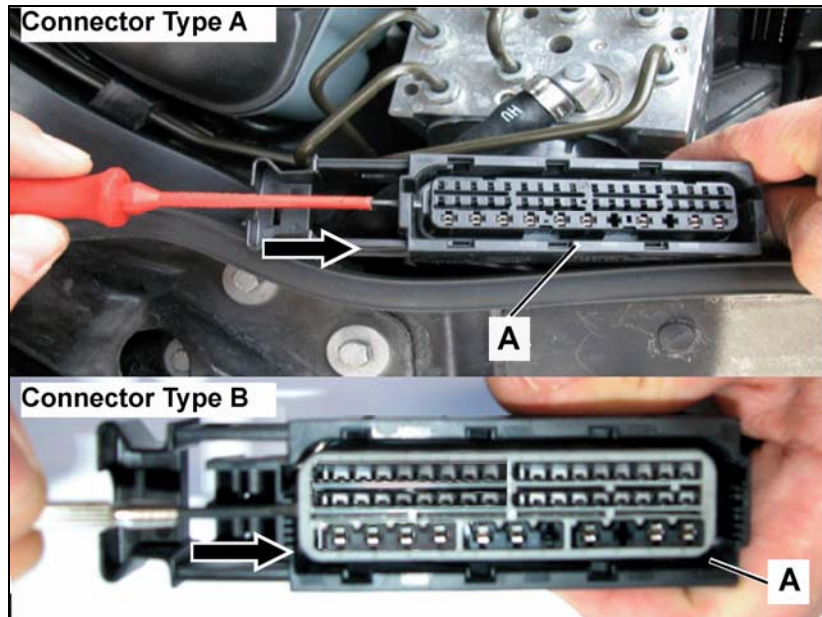

Figure 10

11. Close the (gray) secondary lock of the SBC connector housing (A, Figure 10) by sliding the lock in the direction indicated by the arrows (Figure 10) using a small screwdriver until it locks into place.

12. **Loosely** wrap the exposed SBC wire harness using fabric tape (arrows).
Do not wrap the ground wiring harness (A, Figure 11) into the SBC wire harness.

13. Reinstall the SBC wire harness connector cover in reverse order.

Note:

Ensure the locking lugs (arrows, Figure 6) on the harness connector are properly engaged into the harness connector cover.

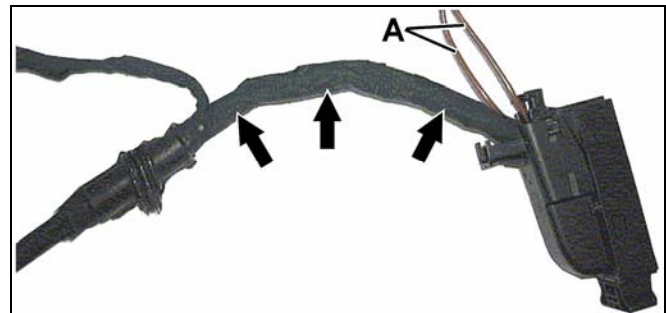

Figure 11

14. Secure the SBC wiring harness (A, Figure 12) (**excluding** the ground wiring harness) to the SBC connector cover harness receptacle (D) using a new cable tie (arrow).

Note:

- Ensure that the SBC wiring harness (A) is properly routed so that it is free of tension in the SBC connector housing.
- The cable tie “buckle” (C) **must be located outside of the connector cover harness receptacle (D) as depicted.**

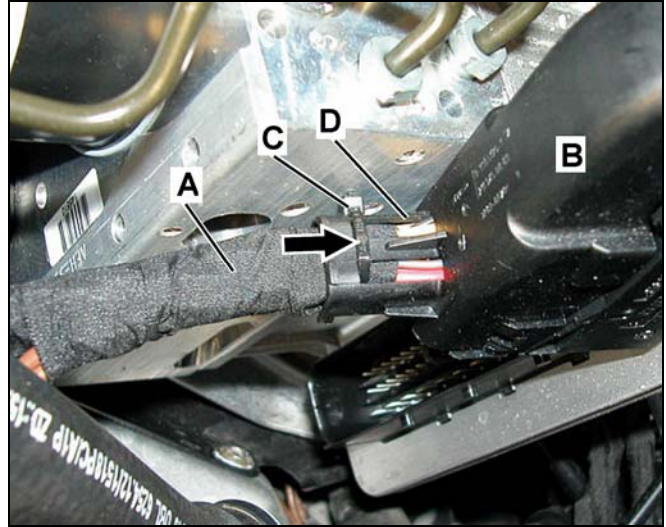

Figure 12

15. Secure ground wiring harness (arrow, Figure 13) to SBC wire harness (A) using two layers of fabric tape (B) in the circled area. Start taping approximately 35 mm (X = 35 mm, Figure 13) from end of connector cover receptacle (C).

Note:

See last bullet of step 23 note concerning fabric tape placement.

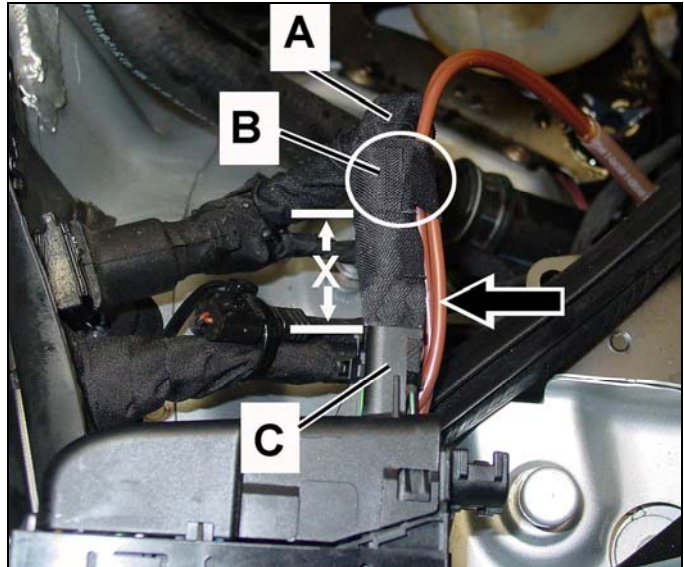

Figure 13

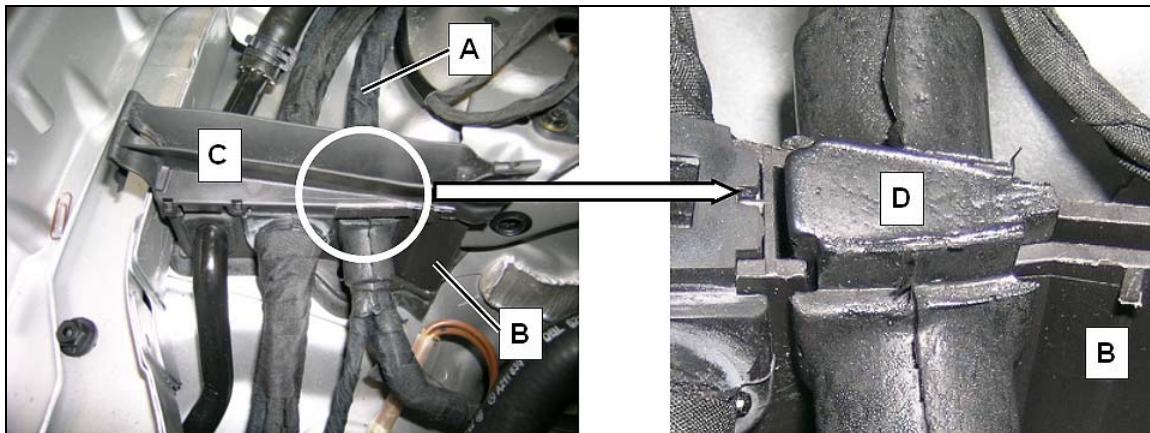

Figure 14

16. Remount the SBC wiring harness (A, Figure 14) in the wire harness guide (B):

- Remove wire guide cover (C) and remove SBC wiring harness with grommet (D) from harness guide (B).

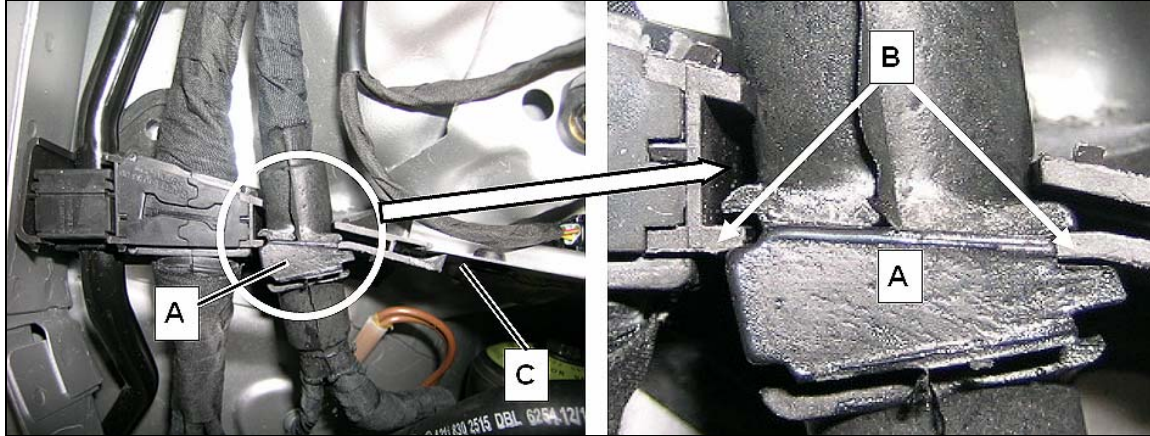

Figure 15

- Reposition wiring harness with grommet (A, Figure 15) into the forward wall opening (B) in the wire guide (C).

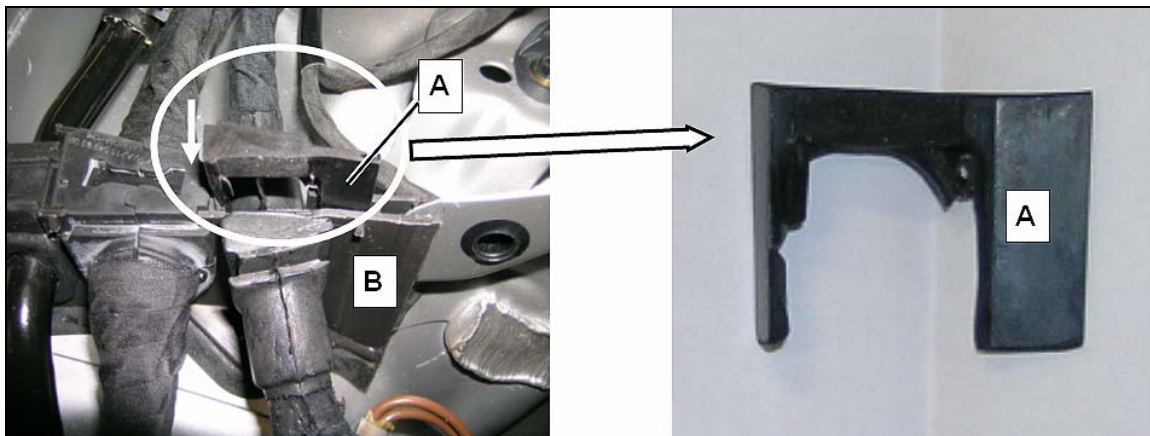

Figure 16

- Insert new routing clip (A, Figure 16) into wire guide (B) until top of clip (A) is flush with top of wire harness guide (B).
- Reinstall top of wire harness guide (C, Figure 14).



Figure 17



Figure 18

17. Attach bracket to the SBC hydraulic unit:

Note:

If mounting bores (arrows, Figure 18) are **not** present in hydraulic unit proceed to step 18, if bores are present continue with this step.

- Using hand tools, tap threads into SBC hydraulic unit bores by running self tapping screw (B, Figure 17) into lower bore **without** mounting bracket positioned on SBC unit.

Note:

- In order to avoid breaking the self-tapping screw (B) during installation, the screw (B) must be **positioned absolutely straight**.
- Do not use power tools to install self tapping screw.
- In the event self tapping screw (B) is broken during installation of bracket (A) perform step 18 then continue with campaign (installation of bracket due to breakage of mounting screw will **not** be covered under warranty).
- Remove self tapping screw (B).
- Position bracket (A) on SBC hydraulic unit, reinstall self tapping screw (B) and torque to 7 Nm.

18. Install clamp-on mounting bracket (B, Figure 19):

- Position mounting bracket (B) onto SBC hydraulic unit (A) as shown in Figure 19.

Note:

- Ensure mounting bracket (B) is flush with SBC hydraulic unit (A).
- Torque mounting clamp screw to 5 Nm while pressing bracket (B) onto SBC unit (A).

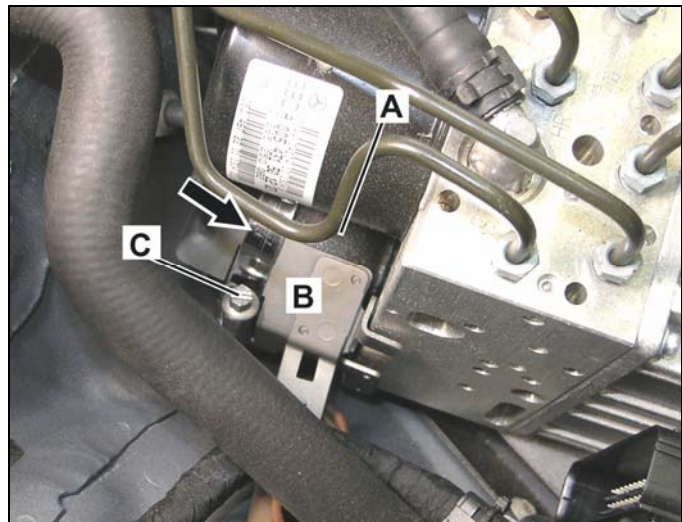

Figure 19

19. Insert a cable tie through slots (arrows, Figure 17) in bracket, **do not** close cable tie.

Note:

Cable tie installation shown on “bolt-on” type mounting bracket, cable tie installation for clamp-on type bracket is similar.

20. Connect the SBC wire harness connector (D, Figure 20) to the SBC hydraulic unit and secure with connector locking mechanism.

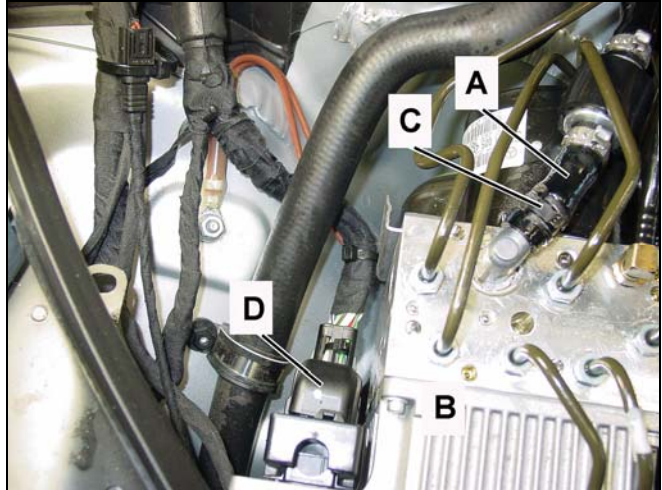

Figure 20

21. Position ground wiring harness parallel to the vehicle longitudinal axis (X-axis) on the body ground terminal. Torque the M6 nut to 10 Nm.

Note:

- Ring connector (A, Figure 21) **must** be positioned as shown to avoid contact with water hose (B) and chafing the wire harness (C).
- This ground terminal (D) is to be used **only** for mounting the SBC ground wire.

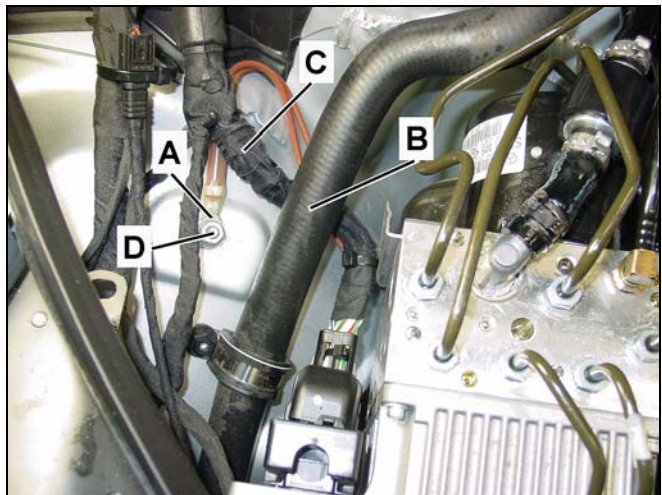

Figure 21

22. Connect SDS and check software release:

Note:

Ensure only the following versions of DAS are used:

- 11/2005 with SBC patch 479 installed on SDS
- Any DAS version after 11/2005

Navigate through the following menu items in DAS and follow on-screen instructions: "Control units/Chassis/SBC - Sensotronic Brake Control/Control unit adaptations".

Note:

- Ensure to follow the on-screen instructions in DAS for connecting programming and terminal inspection tool to the SBC hydraulic unit.
- In the event of malfunctions during the SBC programming, a message will appear in the DAS display and a troubleshooting guide will be displayed.
- In the event DAS indicates that the SBC hydraulic unit requires replacement after inspecting SBC connector terminals, refer to WIS: AR42.46-P-0010R (Model 211) and AR42.46-P-0010TX (Model 219)

for replacement instructions.

Note (regarding above WIS instructions):

Disregard WIS notes regarding brake bleeder pressure. The maximum pressure for brake bleeder is **2.5 bar**.

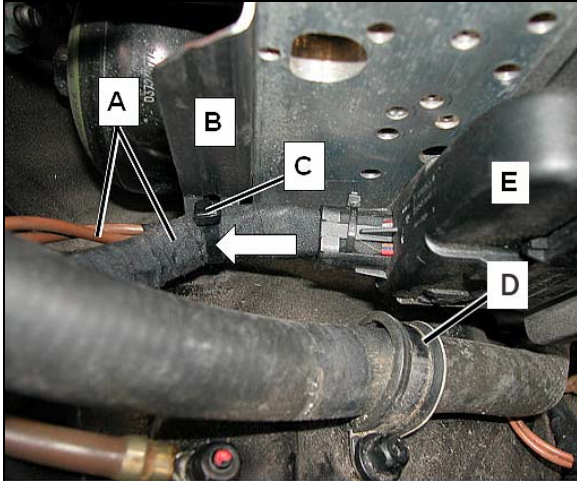

Figure 22

23. Secure ground wiring harness and SBC wiring harness (A, Figure 22) to SBC hydraulic unit bracket (B) with cable tie (arrow). Tighten cable tie (arrow) with Hellermann MK9 cable tie pliers (Special Tool: W 352 589 02 37 00) using **setting 3** on pliers.

Note:

- The cable tie buckle (C) must not touch the bracket (B).
- When mounting the wiring harness set (A) to the bracket (B), ensure that the wiring harness set (A) touches the bracket (B) and is mounted there tension free, ensuring the wiring harness set (A) does not pull on the SBC connector (E).
- After the cable set (A) is secured, it must no longer be possible to move it in the longitudinal direction toward the bracket.
- Disregard WIS notes regarding torque settings on cable tie pliers. Use settings specified in this step.
- The ground wires (A) must be completely wrapped with fabric tape (as performed in step 15) in the area adjacent to the SBC hydraulic unit bracket (B) to ensure that the ground wires do not become chafed. Readjust tape as necessary to prevent chafing.

⚠ CAUTION!

Ensure harness is properly mounted to allow cable strain relief in area between cable tie and connector.

24. Attach hose mounting strap (D, Figure 22) to mounting stud, secure with nut.

25. Proceed to **SUBJECT C – QUALITY ASSURANCE MEASURES**.

C. QUALITY ASSURANCE MEASURES

CAUTION!

Check the quality measures outlined below after completing the service procedure.

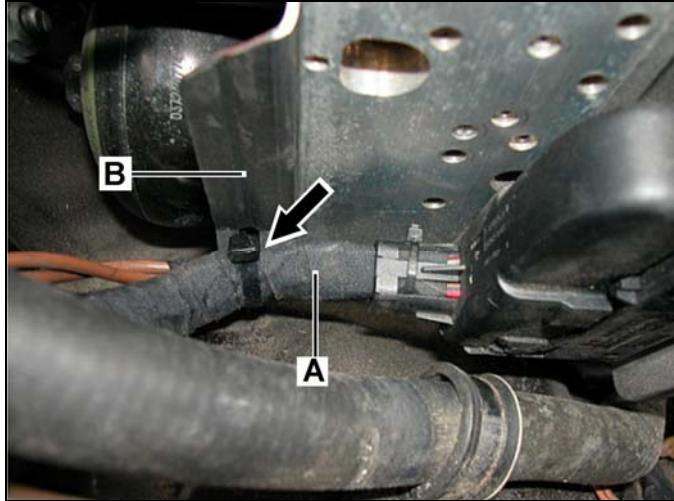

Figure 23

1. Quality measure 1:
 - Ensure cable tie (arrow, Figure 23) was properly affixed using cable tie pliers (Hellermann MK9; special tool number W 352 589 02 37 00); use **setting 3 on cable tie pliers**, as shown in Figure 24.
 - Ensure wiring harness (A, Figure 23) touches the bracket (B, Figure 23) and is mounted there free of tension.

CAUTION!

Ensure harness is properly mounted to allow cable strain relief in area between cable tie and connector.

2. Quality measure 2:
 - Ensure wiring harness (A, Figure 25) and water hose (B, Figure 25) are not touching each other.

CAUTION!

Risk of chafing if wiring harness and water hose are touching.

3. Quality measure 3:
 - Ensure tightening torque on ground terminal stud (arrow, Figure 25) is **between 7 and 10 Nm**.

CAUTION!

Risk of breaking ground terminal stud if torque of 10 Nm is exceeded.



Figure 24

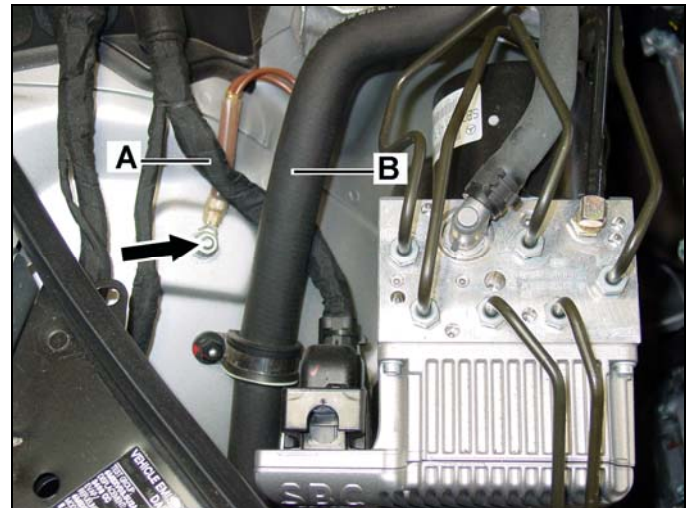

Figure 25

4. Quality measure 4:
- Ensure ground wires (A, Figure 26) are completely wrapped with fabric tape (as performed in step 15) in the area adjacent to the SBC hydraulic unit bracket (B) to ensure that the ground wires do not become chafed. Readjust tape as necessary to prevent chafing.

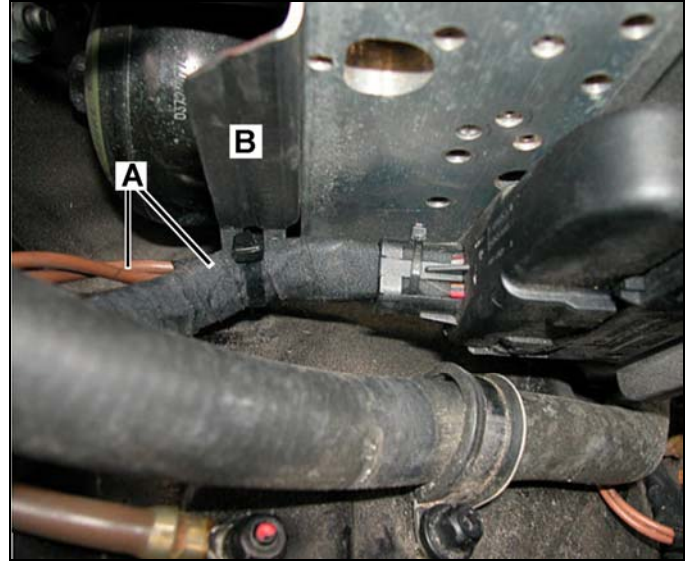
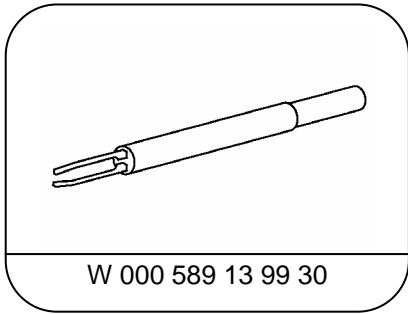
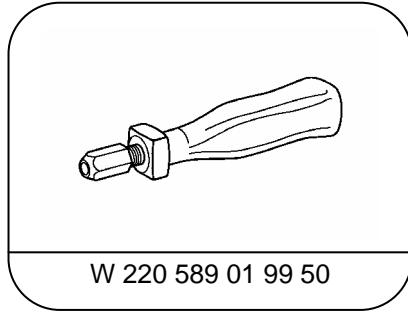

Figure 26

Special Tools



Blade



Handle



Cable tie pliers

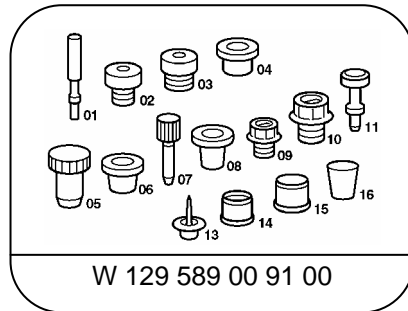

Stop Plug Kit

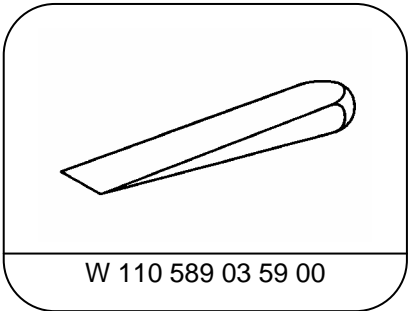

Plastic Wedge

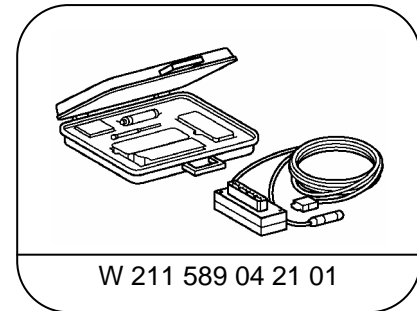

SBC Adapter 2005

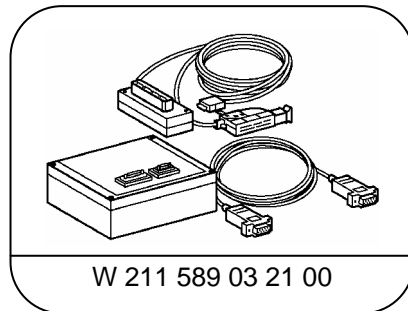

SBC Flash Adapter Set

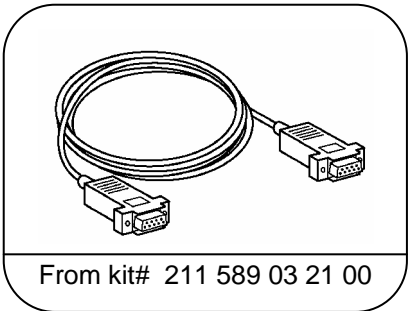

9-Pin Serial Cable

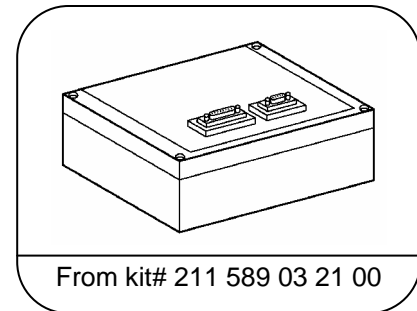

Module Box

Special Tool Information

Special Tool Number	Group/ Category	Description	Dir Net
W 000 589 13 99 30 ¹⁾	00/ B	Blade; MCP/ JPT/ SPT	\$ 41.00
W 220 589 01 99 50 ¹⁾	00/ B	Blade Holder	\$ 9.00
W 352 589 02 37 00 ²⁾	54/ C	Tension Tool; Cable Tie	\$ 404.00
W 129 589 00 91 00 ³⁾	77/ K	Plug Set; Hydraulic	\$ 98.00
W 110 589 03 59 00 ⁴⁾	72/ K	Mounting Wedge	\$ 19.50
W 211 589 04 21 01 ^{5,7)}	54/ B	SBC Adapter 2005	\$ 15.00
W 211 589 03 21 00 ^{6,7)}	54/ B	SBC Flash Adapter Set	\$ 9.75
From kit W211 589 03 21 00 ⁸⁾	54/ B	9-pin Serial Cable	N/A
From kit W211 589 03 21 00 ⁸⁾	54/ B	Module Box	N/A

Note:

¹⁾ Special Tool W 000 589 13 99 30 is interchangeable with W 220 589 01 99 61. Special Tool W 000 589 13 99 30 is the latest replacement for an existing Special Tool W 220 589 01 99 61, released and automatically delivered to all Mercedes-Benz dealers in the Wiring Harness Repair Kit: Special Tool W 220 589 01 99 00 (and later as W 220 589 02 99 00).

²⁾ Special Tool W 352 589 02 37 00 will be released and automatically delivered 1 per each Mercedes-Benz dealer.

³⁾ This required Special Tool should already be in stock at each Mercedes-Benz dealer location.

⁴⁾ This is a sample Special Tool number provided for your reference.

⁵⁾ Special Tool kit W211 589 04 21 01 will be released and automatically delivered to each Mercedes-Benz dealer.

⁶⁾ Use only 9-pin serial cable (W 211 589 03 21 02) and module box (W 211 589 03 21 03) from Special Tool kit W 211 589 03 21 00. Do not use 47-pin adapter cable (W 211 589 03 31 01).

⁷⁾ This Special Tool is not available for dealer order. Because of limited quantities, MBUSA will allocate initial distribution and replacement units as needed on a case-by-case basis. To inquire, please call 201-573-2741.

⁸⁾ These Special Tools were part of the SBC Flash Adapter Set (W 211 589 03 21 00); they cannot be ordered individually.

Required Equipment Information

Part Number	Description	MFR.
275-ST-BBE-2.5 ¹⁾	Brake Bleeder, Stierius	Bodo Stier GmbH (via Power Probe)

Note:

Brake bleeder is available via the MBUSA Standard Service Equipment Program (SSEP) at 1-888-458-4040.

¹⁾ This item was released and automatically delivered to all Mercedes-Benz dealers who did not procure the unit via the MBUSA Standard Service Equipment Program. As a Special Tool, this unit is identified with, and can be ordered using, the MBUSA Special Tool Number: W 900 589 01 71 00.

Primary Parts Information

Qty.	Part Name	Part Number	Estimated Replacement Rate
1	Ground wiring harness	A 211 440 35 08	100%
3	Cable tie	A 001 997 83 90	100%
1	Bracket	A 211 545 00 47 28	100%
1	Guide bracket	A 211 546 74 43	100%
1	Screw (self-tapping)	A 000 990 37 11	100%
1	Interwoven adhesive tape ¹⁾	A 006 989 84 85 10	100%

NOTE:

THE FOLLOWING SECONDARY PART(S) IS/ARE NOT TO BE ORDERED IN EQUAL QUANTITIES AS THE PRIMARY PART(S). THEREFORE DO NOT PACKAGE OR KIT CAMPAIGN PARTS TOGETHER SINCE NOT ALL VEHICLES WILL REQUIRE THESE PARTS.

Secondary Parts Information

Qty.	Part Name	Part Number	Estimated Replacement Rate
1	Bracket (clamp-on)	A 211 545 04 47 05	<1%
1	SBC Hydraulic unit (Model 211)	A 005 431 71 12 05 ²⁾	<1%
		A 005 431 79 12 05 ³⁾	
	SBC Hydraulic unit (Model 219)	A 005 431 81 12 05	
2.25 l	Brake fluid ⁴⁾	A 000 989 08 07 01	<1%

Note:

¹⁾ Submit as local purchase "TPE00013" quantity of 1 (handling is included).

²⁾ The following vehicles require the SBC Hydraulic Unit with part number A 005 431 71 12 05 (32 MHz):

- Vehicles with code 802
- Vehicles with code 803 without code 053

³⁾ The following vehicles require the SBC Hydraulic Unit with part number A 005 431 79 12 05 (40 MHz):

- Vehicles with code 803 and code 053
- Vehicles with code 804

⁴⁾ Submit as local purchase "BRAKEFL01653" quantity of 1 (handling is included).

Note:

- Please be aware that only the part number(s) referenced in the Campaign Bulletin is approved for use to repair the vehicle. Repairs performed using any other part(s) will not have been performed in accordance with the campaign. Accordingly, warranty claims submitted with reference to an improper part number(s) will be denied.
- The following allowable labor operation should be used when submitting a warranty claim for this repair:

Note:

In the event that SBC hydraulic unit replacement becomes necessary, complete and close the Recall Campaign and refer to Netstar message titled "Extended Limited Warranty on SBC Hydraulic Units" dated May 5, 2006.

Warranty Information**Repair 1 (check bracket, install ground wire and bracket, check hydraulic unit)**

Operation: Diagnosis Assistance System (DAS), Connect & Disconnect (02-4762)
Bracket – SBC Wiring Harness, Check (02-4844)
Ground Wire & Bracket – SBC Wiring Harness, Install (02-4846)

Damage Code	Operation Number	Labor Time (hrs.)	Model Indicator(s)
54 960 33 7	02-4762	0.2 h	T1, T2, T3, T4, T5, T6, T7, T8, U1, U3, U4, U5, U6, U7, Y1, Y2
	02-4844	0.1 h	T1, T2, T3, T4, T5, T6, T7, T8, U1, U3, U4, U5, U6, U7, Y1, Y2
	02-4846	0.4 h	T1, T2, T3, T4, T5, T6, T7, T8, U1, U3, U4, U5, U6, U7, Y1, Y2

Repair 2 (check bracket, install ground wire and bracket, check hydraulic unit, perform software update)

Operation: Diagnosis Assistance System (DAS), Connect & Disconnect (02-4762)
Bracket – SBC Wiring Harness, Check (02-4844)
Ground Wire & Bracket – SBC Wiring Harness, Install (02-4846)
Software (DAS Connected), Install (02-4886)

Damage Code	Operation Number	Labor Time (hrs.)	Model Indicator(s)
54 960 33 7	02-4762	0.2 h	T1, T2, T3, T4, T5, T6, T7, T8, U1, U3, U4, U5, U6, U7, Y1, Y2
	02-4844	0.1 h	T1, T2, T3, T4, T5, T6, T7, T8, U1, U3, U4, U5, U6, U7, Y1, Y2
	02-4846	0.4 h	T1, T2, T3, T4, T5, T6, T7, T8, U1, U3, U4, U5, U6, U7, Y1, Y2
	02-4886	0.4 h	T1, T2, T3, T4, T5, T6, T7, T8, U1, U3, U4, U5, U6, U7, Y1, Y2

NOTE REGARDING CUSTOMER REIMBURSEMENT

Reimbursement to customers for repairs performed prior to this recall:

If the customer already paid to have this recall campaign condition repaired and provides adequate documentation to support their claim of a non-warranty repair of this item, they may be eligible to receive reimbursement.

Requests for reimbursement may include parts, labor, fees and taxes.

Reimbursement is limited to the amount the repair of the SBC hydraulic Unit, suction hose, ground wire and bracket, and related parts associated to these replacements (ex. screws, clamps, brake fluid) would have cost if completed by an authorized Mercedes-Benz dealer under this campaign.

Submit a warranty claim, utilizing Damage Code 54960338 as a sublet, utilizing the sublet code of "SUB." Sublet repairs require dealer text as stated in the Warranty Policies and Procedures Manual. Repair date should be the date that the customer paid for the repair.

Note:

Please note the claim submitted for customer reimbursement will **not** close the campaign (if still open). If the customer is still in possession of the vehicle with an open campaign, please arrange to close the campaign in the usual manner as described in this bulletin.

II MODEL 230

INSTALLATION OF GROUND WIRES AND BRACKET TO SBC WIRING HARNESS

Procedure

A. INSPECTION OF BRACKET AND MOUNTING BORES

1. Open hood.
2. Check if the bracket (arrow, Figure 1) is installed on the SBC hydraulic unit:
 - If bracket (arrow) **is** installed, proceed to subject B, step 20: Check software release.
 - If a bracket is **not** installed, proceed to next step.
3. Check for bracket mounting bores (arrows Figure 2) in the SBC hydraulic unit:
 - If bores are **not** present, a clamp-on harness mounting bracket must be installed. Proceed to Subject **B** and complete the procedure in its entirety.
 - If bores **are** present, proceed to subject B and do not perform step 16: Installation of clamp-on mounting bracket.

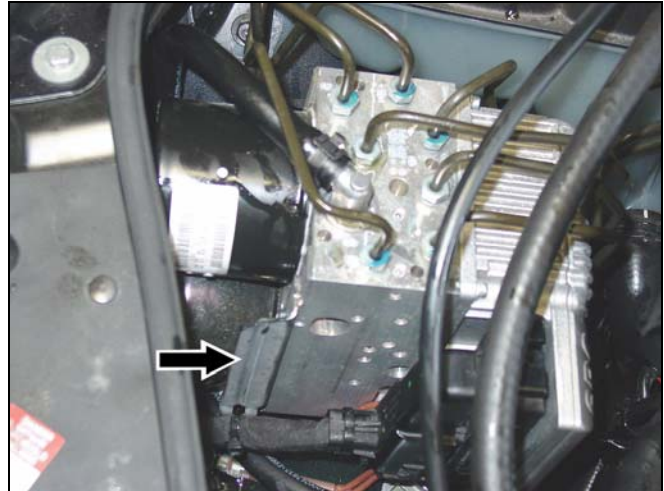

Figure 1

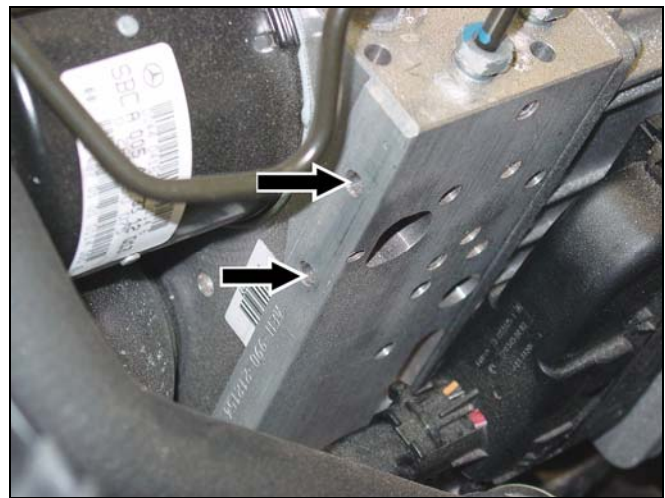

Figure 2

B. INSTALLATION OF GROUND WIRES AND BRACKET TO SBC WIRING HARNESS

1. Lock the vehicle globally and then wait for 30 seconds for the SBC control module to power-down.
2. Remove right intake air duct (arrow, Figure 3).



Figure 3

3. Disconnect SBC hydraulic unit harness connector (arrow, Figure 4) from SBC hydraulic unit (A) and remove cable tie (B, Figure 5).

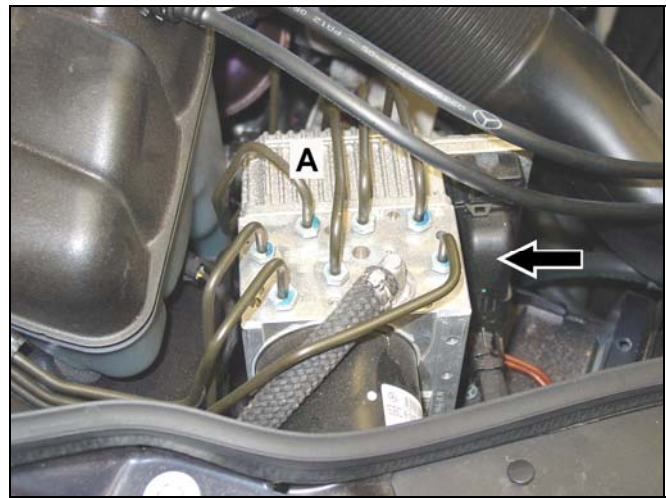

Figure 4

4. Detach the SBC hydraulic unit ground wire harness (arrow, Figure 5) at ground terminal stud (A).

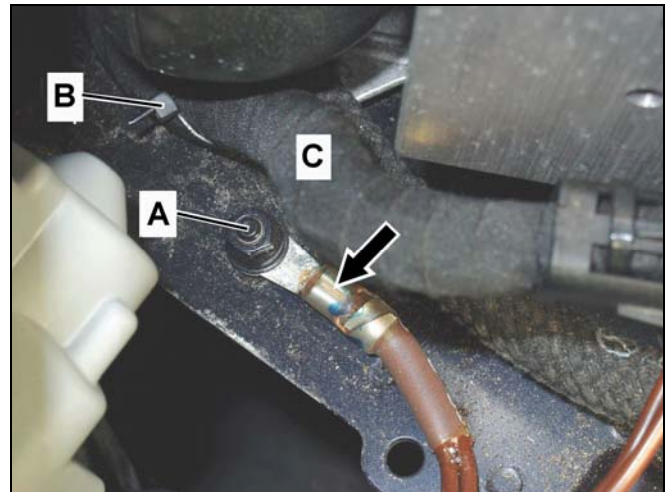

Figure 5

5. Remove cable tie (arrow, Figure 6) securing SBC wire harness (A) to SBC connector housing (B).

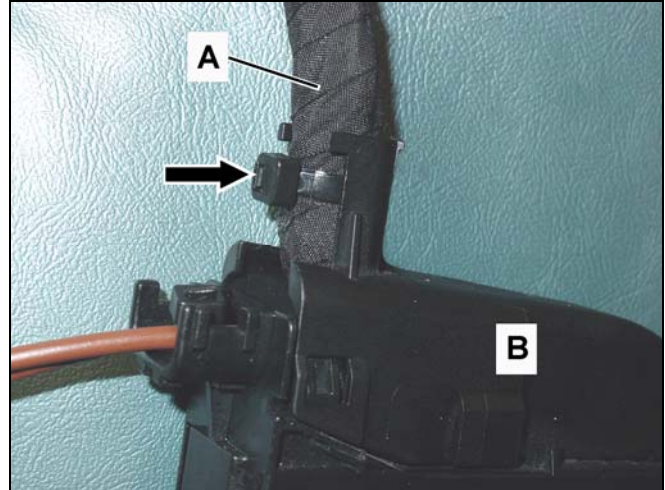

Figure 6

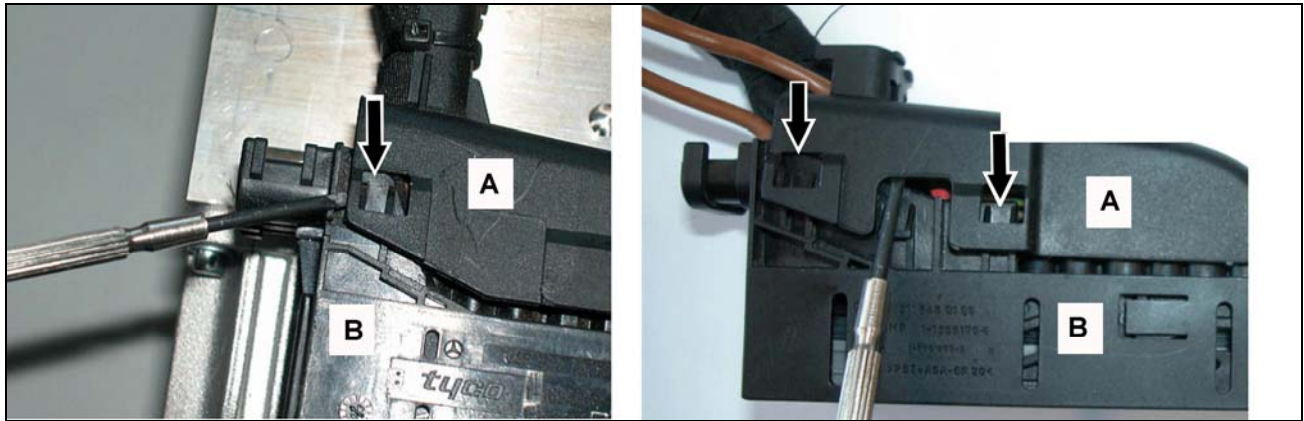

Figure 7

6. Remove SBC connector housing cover (A, Figure 7):
- Using a small screw driver, carefully pry cover (A) away from locking lugs (arrow) until it disengages.
 - Repeat the process on opposite side.
 - Remove the cover (A) from the housing (B).

Note:

There are two different versions of the SBC wiring harness connector (Figure 8a, b) installed in vehicles involved with this campaign.



Figure 8a (Connector Type A)



Figure 8b (Connector Type B)

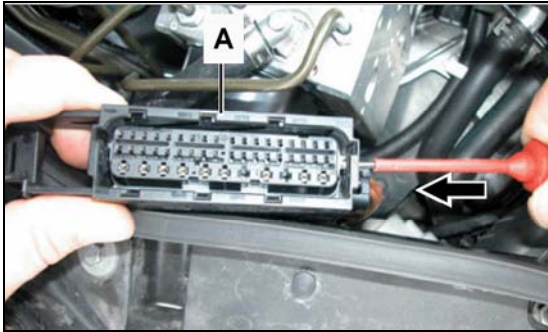

Figure 9a (Connector Type A)



Figure 9b (Connector Type B)

7. Open the (gray) secondary lock in the SBC connector housing (A, Figure 9) by sliding the lock in the direction indicated by the arrows (Figure 9) using a small screwdriver.
8. Remove cable tie (arrow, Figure 10) securing ground wires (A) to SBC connector housing (B).

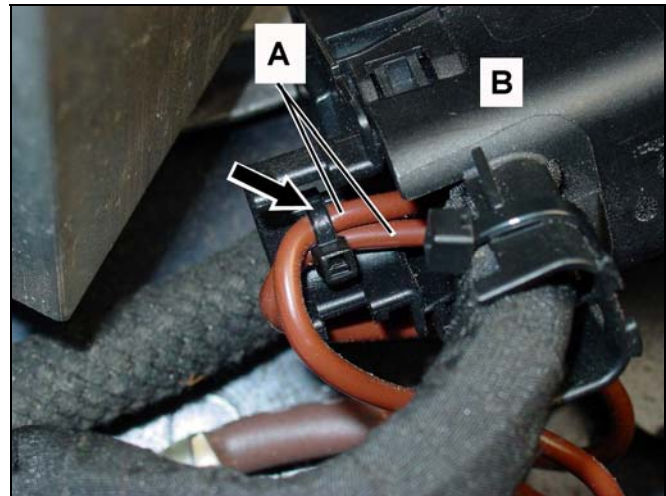

Figure 10

9. Remove SBC ground wires (arrows, Figure 11) from SBC harness connector (A):
 - Unpin ground wire connectors (position 37 and 44, Figure 11) using cable release tool and remove from SBC connector housing (A) (special tool nos.: W 000 589 13 99 30 and W 220 589 01 99 50).
 - Discard old ground wire harness (arrows), it is no longer needed.
10. Insert the new ground wire harness (arrows Figure 11) into the SBC connector housing (A):
 - Insert **longer** ground wire into position 44.
 - Insert **shorter** ground wire into position 37.

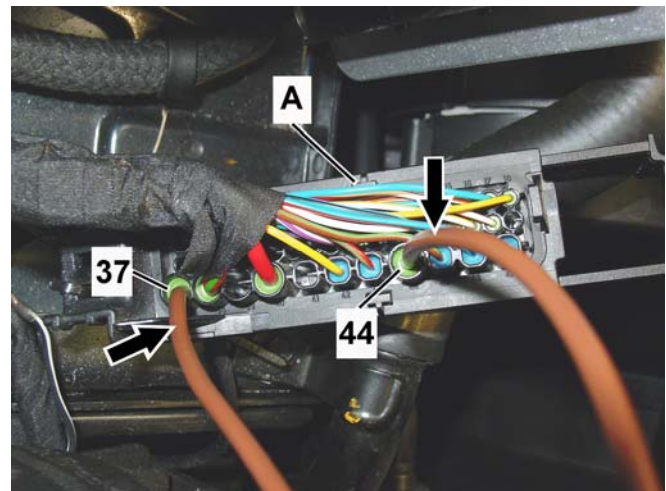

Figure 11

Note:

Ensure ground wire connectors are **properly** locked into place.

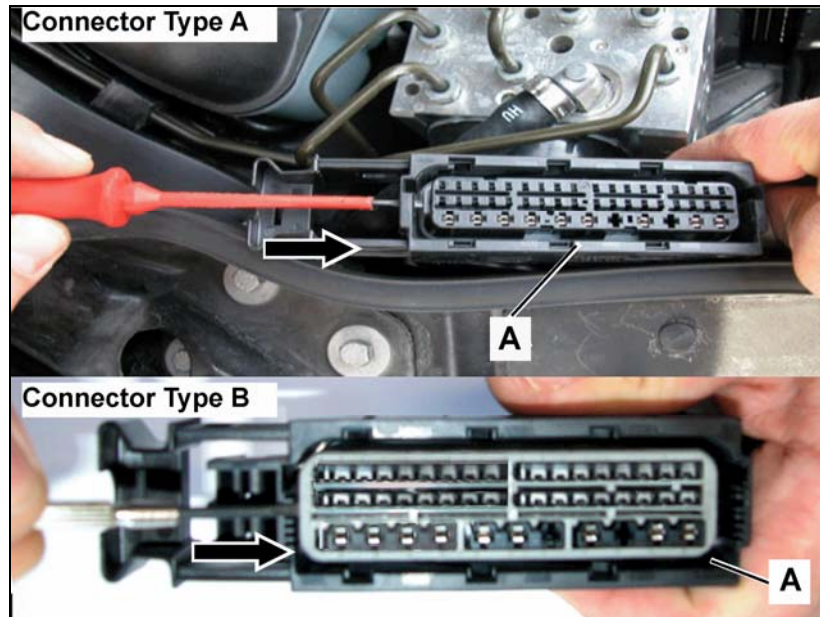

Figure 12

11. Close the (gray) secondary lock of the SBC connector housing (A, Figure 12) by sliding the lock in the direction indicated by the arrows (Figure 12) using a small screwdriver until it locks into place.

12. Reinstall the SBC wire harness connector cover in reverse order.

Note:

Ensure the locking lugs (arrows, Figure 7) on the harness connector are properly engaged into the harness connector cover.

13. Secure SBC wiring harness (A, Figure 13) (excluding ground wires) to the SBC connector cover harness receptacle (arrow) using a new cable tie (B).

Note:

- Ensure that the SBC wiring harness (A) is properly routed so that it is free of tension in the SBC connector housing.
- The cable tie “buckle” (D) **must be located at the side of the connector cover harness receptacle (arrow) as depicted.**

14. Secure ground wiring harness (C, Figure 13) to the SBC connector housing receptacle (F) using a new cable tie (E).

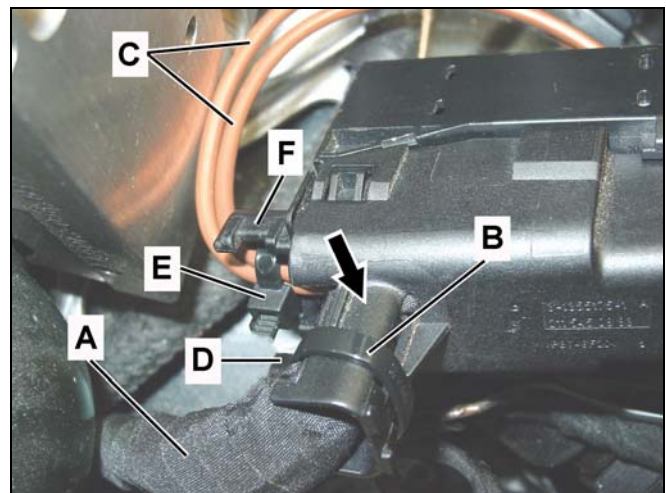

Figure 13

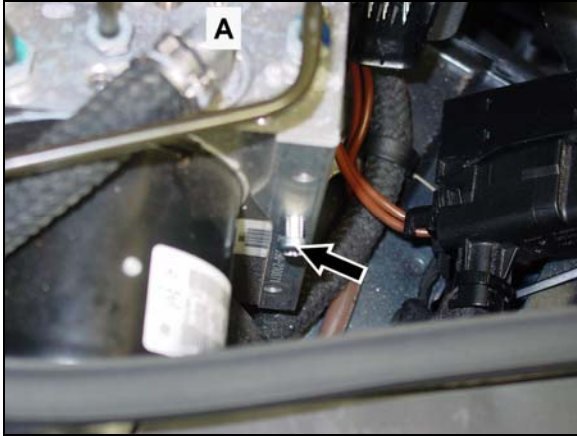

Figure 14



Figure 15

15. Attach bracket (A, Figure 16) to the SBC hydraulic unit (B, Figure 16):

Note:

If mounting bores (arrows, Figure 15) are **not** present in hydraulic unit proceed to step 16, if bores are present continue with this step.

- Using hand tools, tap threads into SBC hydraulic unit bore by running self tapping screw (arrow, Figure 14) into lower bore **without** mounting bracket positioned on SBC unit (A).

Note:

- In order to avoid breaking the self-tapping screw (arrow) during installation, the screw (arrow) must be **positioned absolutely straight**.
- Do not use power tools to install self tapping screw (arrow).
- In the event self tapping screw (arrow) is broken during installation of bracket (A) perform step 16 then continue with campaign (installation of bracket due to breakage of mounting screw will **not** be covered under warranty).
- Remove self tapping screw (arrow).
- Position bracket (A, Figure 16) on SBC hydraulic unit (B), reinstall self tapping screw (arrow) and torque to 7 Nm.

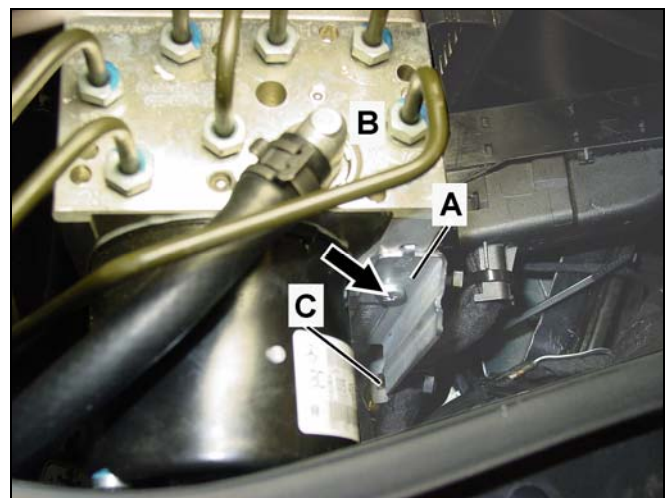

Figure 16

16. Install clamp-on mounting bracket (B, Figure 17) if bores are not present in hydraulic unit:

Note:

Ensure sheathing (arrow) on mounting bracket clamp is positioned as shown in Figure 17.

- Position mounting bracket (B) onto SBC hydraulic unit (A) as shown in Figure 18.



Figure 17

Note:

- Ensure mounting bracket (B, Figure 18) is flush with SBC hydraulic unit (A).
- Torque mounting clamp screw (C) to 5 Nm while pressing bracket (B) onto SBC unit (A).

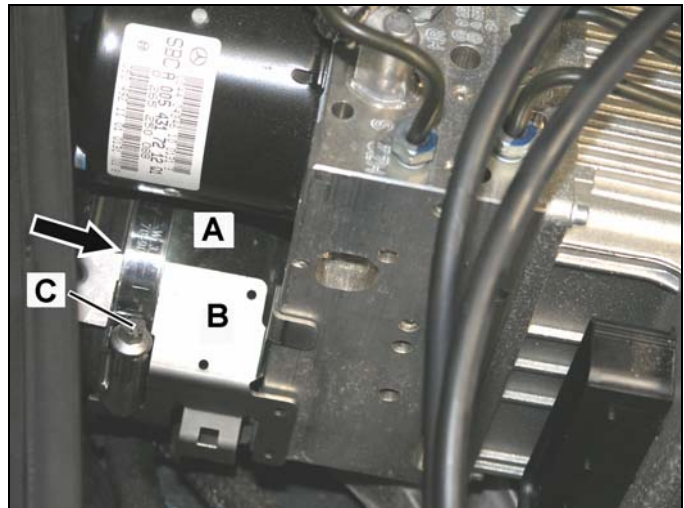

Figure 18

17. Insert a cable tie through slots (C, Figure 16) in bracket (A), **do not** close cable tie.

Note:

Cable tie installation shown on “bolt-on” type mounting bracket, cable tie installation for clamp-on type bracket is similar

18. Connect the SBC wire harness connector (Arrow, Figure 19) to the SBC hydraulic unit and secure with connector locking mechanism.



Figure 19

19. Attach the ground wire harness ring connector (A, Figure 20) to the body ground terminal (B) with M6 nut. Torque the M6 nut to 10 Nm.

Note:

- The ground wire harness (arrow) must be routed under the SBC suction hose (C). The ring connector (A) **must** be positioned as shown in Figure 20.
- This ground terminal (B) is to be used **only** for mounting the SBC ground wire harness (arrow).

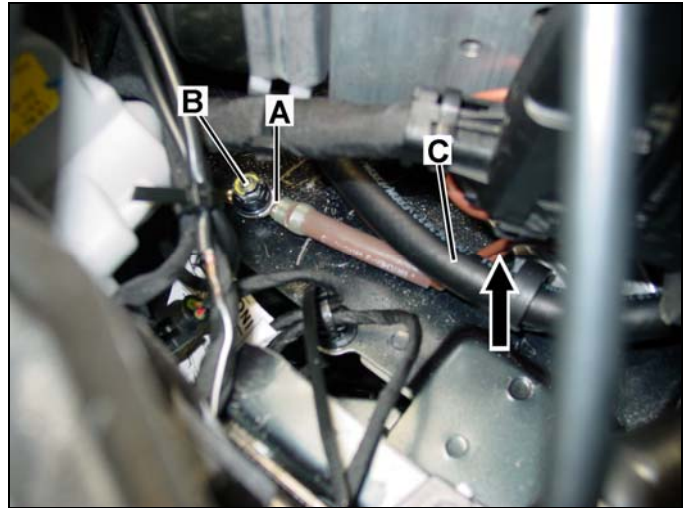

Figure 20

20. Connect SDS and check software release:

Note:

Ensure only the following versions of DAS are used:

- 11/2005 with SBC patch 479 installed on SDS
- Any DAS version after 11/2005

Navigate through the following menu items in DAS and follow on-screen instructions:

"Control units/Chassis/SBC - Sensotronic Brake Control/Control unit adaptations".

Note:

- Ensure to follow the on-screen instructions in DAS for connecting programming and terminal inspection tool to the SBC hydraulic unit.
- In the event of malfunctions during the SBC programming, a message will appear in the DAS display and a troubleshooting guide will be displayed.
- In the event DAS indicates that the SBC hydraulic unit requires replacement after inspecting SBC connector terminals, refer to WIS: AR42.46-P-0010R (for replacement instructions).
- **Note** (regarding above WIS instructions): Disregard WIS notes regarding brake bleeder pressure. The maximum pressure for brake bleeder is **2.5 bar**.

21. Secure SBC wiring harness (A, Figure 21) to SBC hydraulic unit bracket (B) with cable tie (arrow). Tighten cable tie (arrow) using Hellermann MK9 cable tie pliers (Special Tool W 352 589 02 37 00); use **setting 3** on cable tie pliers.

Note

- The cable tie buckle (C) must not touch the bracket (B).
- When attaching SBC wire harness (A) to the bracket (B), ensure that the wire harness (A) touches the bracket (B) and is mounted there tension free.
- After the SBC cable (A) is secured, it must no longer be possible to move it in the longitudinal direction toward the bracket.
- Disregard WIS notes regarding torque settings on cable tie pliers. Use settings specified in this step.

⚠ CAUTION!

Ensure harness is properly mounted to allow cable strain relief in area between cable tie and connector.

22. Proceed to **SUBJECT C – QUALITY ASSURANCE MEASURES.**

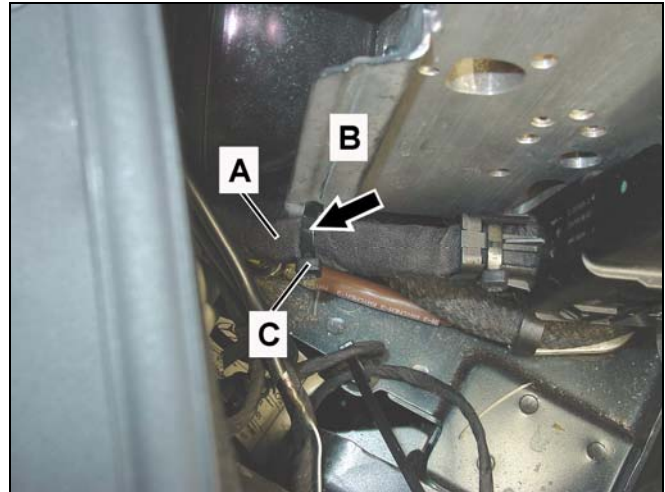

Figure 21

C. QUALITY ASSURANCE MEASURES

CAUTION!

Check the quality measures outlined below after completing the service procedure.



Figure 22



Figure 23

1. Quality measure 1:

- Ensure cable tie (arrow, Figure 22) was properly affixed using cable tie pliers (Hellermann MK9; special tool number W 352 589 02 37 00); use **setting 3 on cable tie pliers**, as shown in Figure 23.
- Ensure wiring harness (A, Figure 24) touches the bracket (C, Figure 24) and is mounted there tension free.

CAUTION!

Ensure harness is properly mounted to allow cable strain relief in area between cable tie and connector.

2. Quality measure 2:

- Ensure wiring harness (A, Figure 24) and water hose (B, Figure 24) are not touching each other.

CAUTION!

Risk of chafing if wiring harness and water hose are touching.

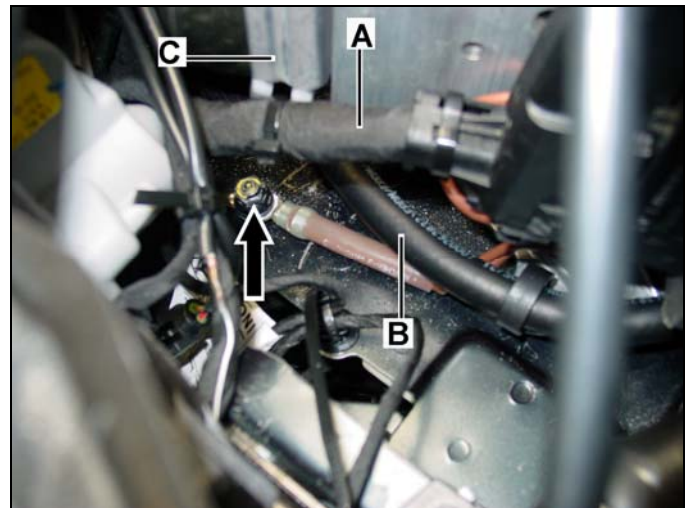

Figure 24

3. Quality measure 3:

- Ensure tightening torque on ground terminal stud (arrow, Figure 24) is **between 7 and 10 Nm**.

CAUTION!

Risk of breaking ground terminal stud if torque of 10 Nm is exceeded.

Special Tools

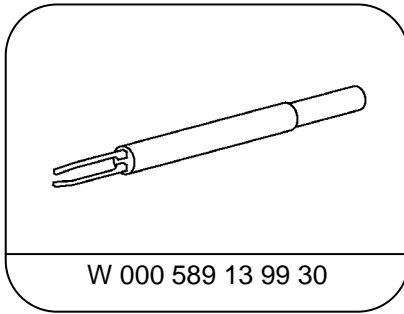

Blade

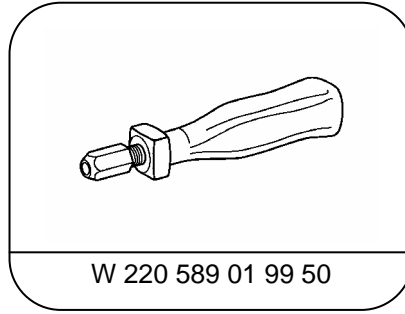

Handle



Cable tie pliers

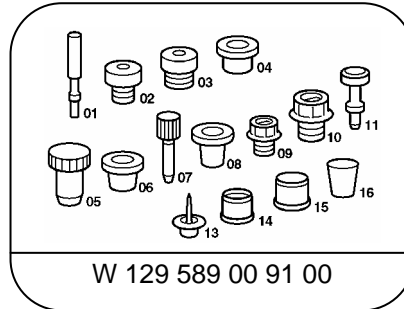

Stop Plug Kit

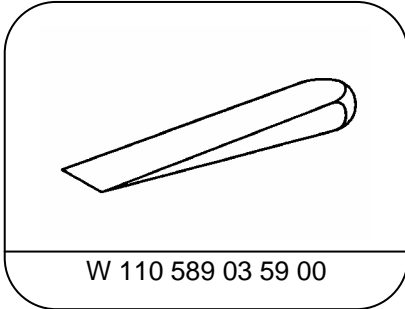

Plastic Wedge

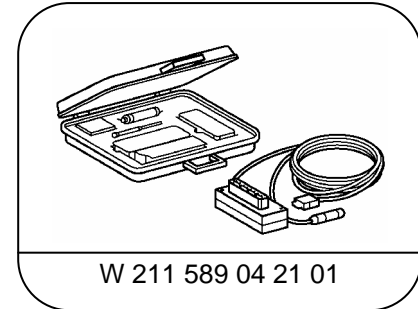

SBC Adapter 2005

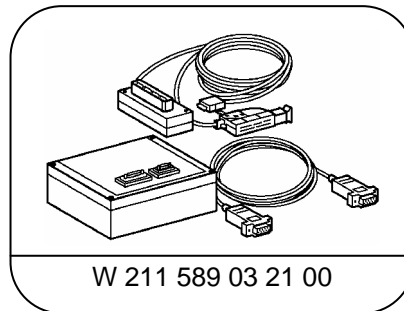

SBC Flash Adapter Set

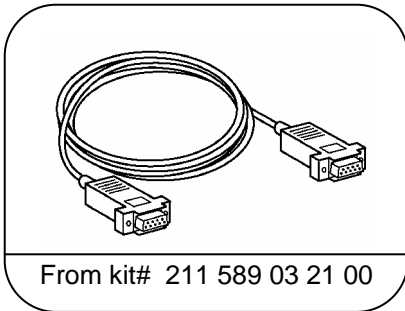

9-Pin Serial Cable

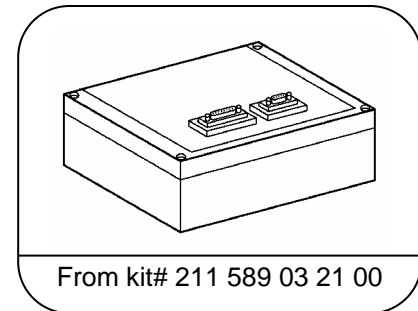

Module Box

Special Tool Information

Special Tool Number	Group/ Category	Description	Dir Net
W 000 589 13 99 30 ¹⁾	00/ B	Blade; MCP/ JPT/ SPT	\$ 41.00
W 220 589 01 99 50 ¹⁾	00/ B	Blade Holder	\$ 9.00
W 352 589 02 37 00 ²⁾	54/ C	Tension Tool; Cable Tie	\$ 404.00
W 129 589 00 91 00 ³⁾	77/ K	Plug Set; Hydraulic	\$ 98.00
W 110 589 03 59 00 ⁴⁾	72/ K	Mounting Wedge	\$ 19.50
W 211 589 04 21 01 ^{5,7)}	54/ B	SBC Adapter 2005	\$ 15.00
W 211 589 03 21 00 ^{6,7)}	54/ B	SBC Flash Adapter Set	\$ 9.75
From kit W211 589 03 21 00 ⁸⁾	54/ B	9-pin Serial Cable	N/A
From kit W211 589 03 21 00 ⁸⁾	54/ B	Module Box	N/A

Note:

¹⁾ Special Tool W 000 589 13 99 30 is interchangeable with W 220 589 01 99 61. Special Tool W 000 589 13 99 30 is the latest replacement for an existing Special Tool W 220 589 01 99 61, released and automatically delivered to all Mercedes-Benz dealers in the Wiring Harness Repair Kit: Special Tool W 220 589 01 99 00 (and later as W 220 589 02 99 00).

²⁾ Special Tool W 352 589 02 37 00 will be released and automatically delivered 1 per each Mercedes-Benz dealer.

³⁾ This required Special Tool should already be in stock at each Mercedes-Benz dealer location.

⁴⁾ This is a sample Special Tool number provided for your reference.

⁵⁾ Special Tool kit W211 589 04 21 01 will be released and automatically delivered to each Mercedes-Benz dealer.

⁶⁾ Use only 9-pin serial cable (W 211 589 03 21 02) and module box (W 211 589 03 21 03) from Special Tool kit W 211 589 03 21 00. Do not use 47-pin adapter cable (W 211 589 03 31 01).

⁷⁾ This Special Tool is not available for dealer order. Because of limited quantities, MBUSA will allocate initial distribution and replacement units as needed on a case-by-case basis. To inquire, please call 201-573-2741.

⁸⁾ These Special Tools were part of the SBC Flash Adapter Set (W 211 589 03 21 00); they cannot be ordered individually.

Required Equipment Information

Part Number	Description	MFR.
275-ST-BBE-2.5 ¹⁾	Brake Bleeder, Stierius	Bodo Stier GmbH (via Power Probe)

Note:

Brake bleeder is available via the MBUSA Standard Service Equipment Program (SSEP) at 1-888-458-4040.

¹⁾ This item was released and automatically delivered to all Mercedes-Benz dealers who did not procure the unit via the MBUSA Standard Service Equipment Program. As a Special Tool, this unit is identified with, and can be ordered using, the MBUSA Special Tool Number: W 900 589 01 71 00.

Primary Parts Information

Qty.	Part Name	Part Number	Estimated Replacement Rate
1	Ground wiring harness	A 230 540 92 10 05	100%
3	Cable tie	A 001 997 83 90 (VPE100)	100%
1	Bracket	A 230 545 00 47 05	100%
1	Screw (self-tapping)	N 007516 005106	100%

NOTE:

THE FOLLOWING SECONDARY PART(S) IS/ARE NOT TO BE ORDERED IN EQUAL QUANTITIES AS THE PRIMARY PART(S). THEREFORE DO NOT PACKAGE OR KIT CAMPAIGN PARTS TOGETHER SINCE NOT ALL VEHICLES WILL REQUIRE THESE PARTS.

Secondary Parts Information

Qty.	Part Name	Part Number	Estimated Replacement Rate
1	Bracket (clamp-on)	A 230 545 01 47 05	<1%
1	SBC Hydraulic unit	A 005 431 71 12 05 ¹⁾ A 005 431 79 12 05 ²⁾	<1%
2.25 l	Brake fluid ³⁾	A 000 989 08 07 01	<1%

Note:

- ¹⁾ The following vehicles require the SBC Hydraulic Unit with part number A 005 431 71 12 05 (32 MHz):
- Vehicles with code 802
 - Vehicles with code 803 without code 053
- ²⁾ The following vehicles require the SBC Hydraulic Unit with part number A 005 431 79 12 05 (40 MHz):
- Vehicles with code 803 and code 053
 - Vehicles with code 804
- ³⁾ Submit as local purchase "BRAKEFL01653" quantity of 1 (handling is included).

Note:

- Please be aware that only the part number(s) referenced in the Campaign Bulletin is approved for use to repair the vehicle. Repairs performed using any other part(s) will not have been performed in accordance with the campaign. Accordingly, warranty claims submitted with reference to an improper part number(s) will be denied.
- The following allowable labor operation should be used when submitting a warranty claim for this repair:

Note:

In the event that SBC hydraulic unit replacement becomes necessary, complete and close the Recall Campaign and refer to Netstar message titled "Extended Limited Warranty on SBC Hydraulic Units" dated May 5, 2006.

Warranty Information**Repair 1 (Check bracket, install ground wire and bracket, check hydraulic unit)**

Operation: Diagnosis Assistance System (DAS), Connect & Disconnect (02-4762)
Bracket – SBC Wiring Harness, Check (02-4844)
Ground Wire & Bracket – SBC Wiring Harness, Install (02-4846)

Damage Code	Operation Number	Labor Time (hrs.)	Model Indicator(s)
54 960 33 7	02 4762	0.2 h	R1, R2, R3, R4
	02 4844	0.1 h	R1, R2, R3, R4
	02 4846	0.4 h	R1, R2, R3, R4

Repair 2 (Check bracket, install ground wire and bracket, check hydraulic unit, perform software update)

Operation: Diagnosis Assistance System (DAS), Connect & Disconnect (02-4762)
Bracket – SBC Wiring Harness, Check (02-4844)
Ground Wire & Bracket – SBC Wiring Harness, Install (02-4846)
Software (DAS Connected), Install (02-4886)

Damage Code	Operation Number	Labor Time (hrs.)	Model Indicator(s)
54 960 33 7	02 4762	0.2 h	R1, R2, R3, R4
	02 4844	0.1 h	R1, R2, R3, R4
	02 4846	0.4 h	R1, R2, R3, R4
	02-4886	0.4 h	R1, R2, R3, R4

NOTE REGARDING CUSTOMER REIMBURSEMENT

Reimbursement to customers for repairs performed prior to this recall:

If the customer already paid to have this recall campaign condition repaired and provides adequate documentation to support their claim of a non-warranty repair of this item, they may be eligible to receive reimbursement.

Requests for reimbursement may include parts, labor, fees and taxes.

Reimbursement is limited to the amount the repair of the SBC hydraulic Unit, suction hose, ground wire and bracket, and related parts associated to these replacements (ex. screws, clamps, brake fluid) would have cost if completed by an authorized Mercedes-Benz dealer under this campaign.

Submit a warranty claim, utilizing Damage Code 54960338 as a sublet, utilizing the sublet code of "SUB." Sublet repairs require dealer text as stated in the Warranty Policies and Procedures Manual. Repair date should be the date that the customer paid for the repair.

Note:

Please note the claim submitted for customer reimbursement will **not** close the campaign (if still open). If the customer is still in possession of the vehicle with an open campaign, please arrange to close the campaign in the usual manner as described in this bulletin.

Safety Recall #2005110001

December, 2005

Dear Mercedes-Benz Owner

This notice is sent to you in accordance with the requirements of the National Traffic and Motor Vehicle Safety Act. WE SENT YOU THIS NOTICE BECAUSE WE ARE CONCERNED ABOUT YOUR SAFETY.

DaimlerChrysler AG (DCAG), the manufacturer of Mercedes-Benz vehicles, has decided that a defect which relates to motor vehicle safety exists in certain Model Year 2003 – 2005 E-Class, 2003 – 2005 SL-Class, and 2006 CLS-Class vehicles equipped with Sensotronic Brake Control (SBC). Mercedes-Benz USA, LLC (MBUSA) therefore has initiated a recall of these vehicles. Our records indicate that your vehicle is included in the affected population of vehicles.

The SBC brake system in certain E-Class, SL-Class and CLS vehicles, in certain instances, may shift to the hydraulic back up mode due to a loosening of the ground wire harness connection over time. In the hydraulic back up mode, the driver has braking power sufficient to stop the vehicle, although greater brake pedal pressure is required and the brake pedal travel will be noticeably longer which could lead to a vehicle crash.

Your authorized Mercedes-Benz dealer has available a bracket and replacement ground wire that it will install on your vehicle's SBC pump unit to correct the situation described above by preventing loosening of the new ground wire harness connection. This service will be provided free of charge. The working time required is approximately 1 hour. As a matter of normal service process, your authorized Mercedes-Benz dealer will also check for other repair measures which might be applicable to your vehicle and this may increase the required working time. Please contact your authorized Mercedes-Benz dealer for additional information and to schedule an appointment at your earliest convenience. Please mention Recall Campaign #2005110001.

If you are no longer the vehicle owner, or have a change of address, please complete the reverse side of this letter and return the complete letter in the enclosed envelope. If this is a leased vehicle and the lessor and registered owner receive this notice, please forward this information by first class mail to the lessee. If you have paid to have this recall condition corrected prior to this notice you may be eligible to receive reimbursement. Please see the reverse side of this notice for details.

Please contact your authorized Mercedes-Benz dealer should you have any questions or encounter any difficulty regarding this recall. If your dealer is unable to remedy your situation please contact us at 1-(800) FOR-MERCedes (1-800-367-6372).

If an authorized Mercedes-Benz dealer or Mercedes-Benz USA, LLC, fails or is unable to perform this service without charge within 60 days, pursuant to law 49 U.S.C. Chapter 301, you may submit a complaint to the Administrator, National Highway Traffic Safety Administration, 400 Seventh Street, S.W., Washington, D.C. 20590 or call the toll-free Auto Safety Hotline at 1-888-327-4236 (TTY 1-800-424-9153); or go to <http://www.safercar.gov>.

We apologize for any inconvenience this situation may cause you.

Sincerely,

Klaus Ulkann
Vice President
Customer Services