

MODEL 203.08 /28, 204.08 /09 /28 /29 /98, 211.08 /09 /28 /29, 212.08 /09 /28 /29, 216.38, 220.08 /18, 221.08 /18
outer boot

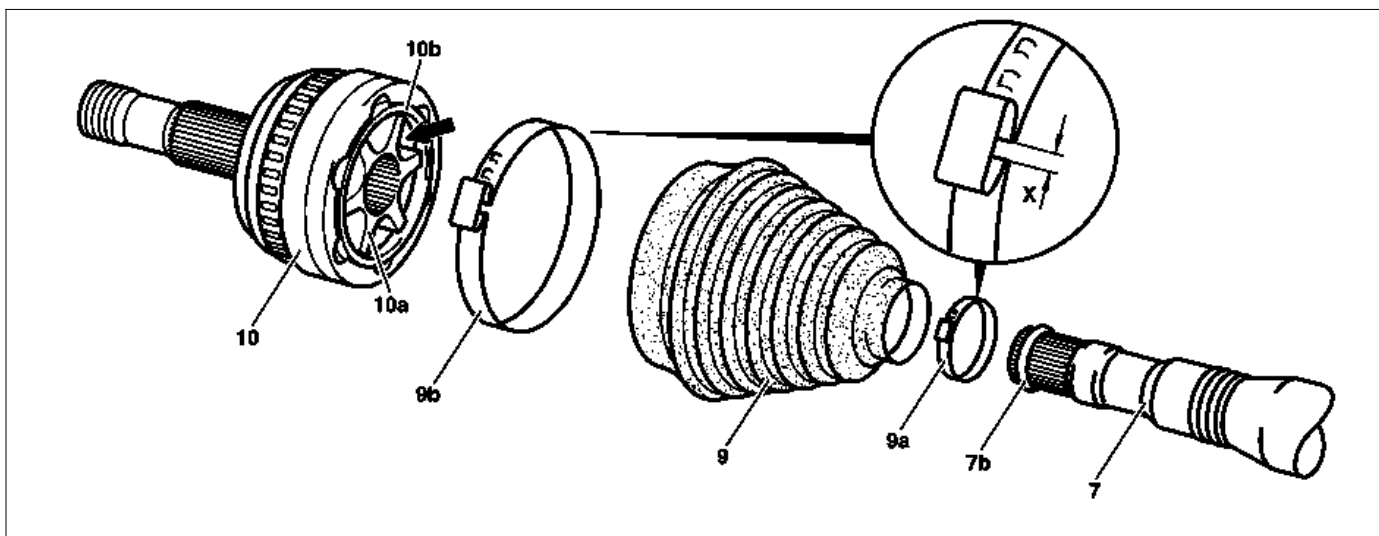

P33.30-2004-08

7 Front axle shaft
7b Retaining ring

9 Boot
9a Clamp
9b Clamp

10 Articulated
10a Internal spider
10b Cage

Modification notes

13.8.09	Value changed: Outer joint (wheel side)	Model 221.08/18	*BF33.30-P-1001-02B
---------	---	-----------------	-------------------------------------

	Removing		
1	Remove front axle shaft (7)	Model 203 Model 211, 220 Model 216, 221 Model 204, 212	AR33.30-P-0620P AR33.30-P-0620I AR33.30-P-0620SYZ AR33.30-P-0620CWX
	Disassemble		
2	Remove hose clamps (9a, 9b)	i Installation: Replace the clamps (9a, 9b).	
3	Cut open boot (9), pull it off and detach ball joint (10) from front axle shaft (7)	i To do so clamp front axle shaft in vise. ⚠ Do not damage the contact surfaces of the radial sealing rings. Drive ball joint off front axle shaft at inner star (10a, arrow). Use suitable drift (steel).	
	Clean		
4	Clean ball joint (10)	i The ball joint must be disassembled if there is evidence of water entry or soiling. To do so, mark the positions of the ball joint, inner star (10a) and cage (10b) relative to each other.	
	Assembly		
5	Push clamp (9a) onto front axle shaft (7)		
6	Push new boot (9) onto front axle shaft (7)		
7	Fill ball joint (10) with grease up to upper edge of inner star (10a)	⚠	*BF33.30-P-1001-02B
8	Slide ball joint (10) onto front axle shaft (7)	i Install a new retaining ring (7b).	
9	Fill boot (9) and ball joint (10) with rest of grease		
10	Slide boot (9) onto ball joint (10) and front axle shaft (7)	i The raised bead of the boot must lie in the groove on the ball joint and in the center groove of the front axle shaft.	
11	Fasten hose clamps (9a, 9b)	i Fasten hose clamps using clamp pliers. The spindle of the clamp pliers must be tightened securely in order to ensure that the clamps are seated adequately. Dimension "X" must be ≤ 2.5 mm.	
	Install		
12	Install front axle shaft (7)	Model 203 Model 211, 220	AR33.30-P-0620P AR33.30-P-0620I

 **Front axle shaft**

Number	Designation	Model 203.08/09/28/29	Model 211.08/09/ 28/29	Model 220.08/18
BF33.30-P-1001-02B	Outer joint (wheel side)	Filling capacity g 120	120	120
		Specifications for Operating Fluids Sheet -	-	-

 **Front axle shaft**

Number	Designation	Model 204.08/09/28/29	Model 204.98	Model 212.08/09/28/29
BF33.30-P-1001-02B	Outer joint (wheel side)	Filling capacity g 140	140	140
		Specifications for Operating Fluids Sheet -	-	-

 **Front axle shaft**

Number	Designation	Model 216 with 4MATIC	Model 221 with 4MATIC
BF33.30-P-1001-02B	Outer joint (wheel side)	Filling capacity g 140	140
		Specifications for Operating Fluids Sheet -	-